

Model

Horizon Series™ HLR104-ADA Undercounter Laboratory/Pharmacy Refrigerator

Specifications

Application, Rating and Electrical Data		Controller	
Application	Storage of medical and scientific products	Interface	LED digital display, °C or °F
Storage Volume	4 cu ft (113 L)	Power Switch	On/Off
Temperature Range	2° to 10°C	Controller Type	Microprocessor-based controller with alarm/monitor
Electrical Power	115V 60Hz	Security	Lockable door, optional keypad access
Maximum Current	5 FLA	Control Sensor	RTD
Building Supply Rating	15 amp dedicated ground circuit	High / Low Alarms	Fully adjustable
Power Plug / Power Cord Length	NEMA 5-15 hospital grade plug (115V) 8-10 ft (2439-3048 mm)	Door Ajar Alarm	Yes
Certification / Agency Listing	QPS (Certified to UL and CSA Standards)	Power Failure Alarm	Yes
Indoor/Outdoor Use	Indoor use only	Min/Max Display and Reset	Yes
Application Environment	Non-corrosive, non-flammable, non-explosive, 15°C to 32°C (59°F to 90°F)	Battery Back-up	9-volt non-rechargeable
Refrigeration System		Dimensions and Construction	
Refrigeration System	Forced-air circulation	Interior (w x h x d)	19.5 x 17.75 x 22 in 496 x 451 x 559 mm
Compressor / Number	.17 HP (115V) hermetic / 1	Exterior (w x h x d) (Includes leveling feet)	24 x 32 x 26.75 in 610 x 813 x 680 mm
Condenser Type / Number	Air-cooled fin and tube / 1	Overall Exterior (w x h x d) (Includes door handle and leveling feet)	24 x 32 x 28.5 in 610 x 813 x 724 mm
Expansion Device	Cap tube	ADA Compatible	Fits under 34" (864 mm) ADA compliant counters
Evaporator Type	Air-cooled fin and tube	Insulation	Sustainable, U.S. EPA and SNAP approved Ecomate®
Defrost Method	Automatic	Exterior / Interior Finish	Bacteria-resistant powder coating
Refrigerant Charge	R134A Non-CFC	Doors	1, Solid
Performance Data		Access Ports	Rear access port
Uniformity	+/-1.5°C at 4°C Setpoint	Interior Storage / Capacity	2 epoxy coated shelves 18 x 18 in (458 x 458 mm) 100 lb (46 kg) max capacity / shelf
Warranty		Leveling Feet	Standard
Rel.i™ (US/Canada)	5 years compressor, 2 years parts, 1 year labor	Casters	Optional / swivel locking
Outside US/Canada	Consult your local representative	Integrated Access Control	Optional - Electromagnetic lock via digital keypad
		Net Weight	185 lb (84 kg)
		Shipping Weight	250 lb (114 kg)
		Clearance Requirements	Minimum of 3" (76mm) behind unit for clearance and feature access.
		Options / Accessories	Chart Recorder, Stacking Kit, Floor & Wall Bracket Kit, Remote Alarms, Interior Light, Glass Door, Casters, Stainless Steel Interior and Exterior, Remote Lock Adapter Kit, Extended Warranty



Technical Data Sheet

Laboratory / Pharmacy Refrigerator

Horizon Series™ HLR104-ADA

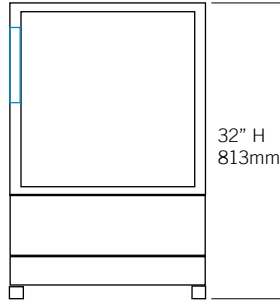

Note: Height with optional casters
33.5 in (851 mm)

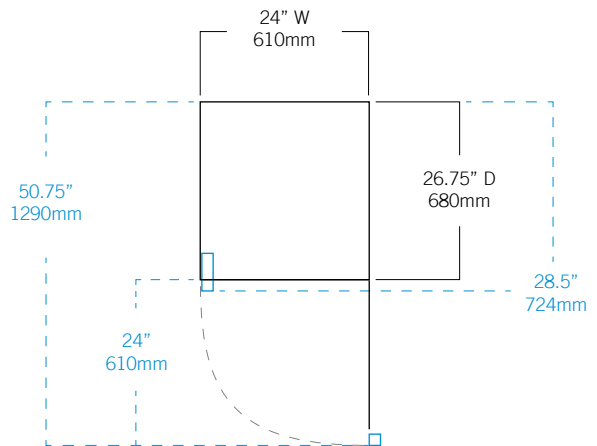
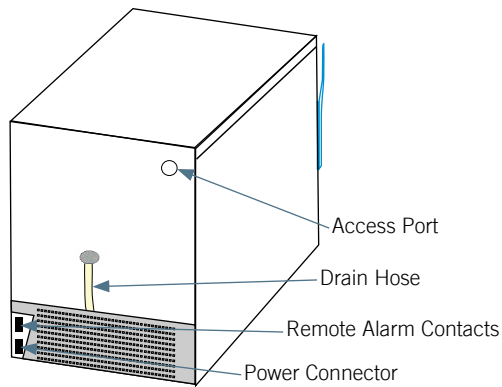
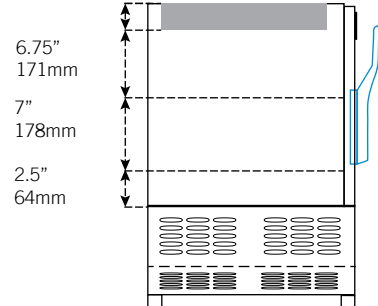

Helmer Scientific | 14400 Bergen Boulevard | Noblesville, IN 46060 | USA
+1.317.773.9073 | www.helmerinc.com



© 2015 Helmer Inc. All rights reserved. 380319-1/D 6/16
All trademarks are the property of Helmer Scientific. Specifications subject to change.