

# Echo

Protector® Echo™ Filtered Fume Hoods





## Protector® Echo™ Filtered Fume Hoods

Labconco has combined its patented\* fully-featured, containment-enhancing Protector® Hood design with Erlab's GreenFumeHood® (GFH) Filtration Technology to deliver a multi-use fume hood that requires no ducting. The Protector® Echo™ Filtered Fume Hood delivers safety, energy savings and adaptability to ever-changing lab spaces.

### The Benefits of GFH Filtration Technology

Safety-driven safety sums up the benefits of GFH Filtration Technology, which allow the Protector Echo Filtered Fume Hood to perform well beyond the SEFA 9 DH III definition (Table 1). The user's safety is maintained because the Protector Echo has built-in features that constantly monitor and prevent unsafe conditions without relying on user practices or modifications. These safeguards include:

- Controlled access to specified users via radio frequency identification (RFID) cards. Unauthorized personnel are prevented from operating the hood.
- Sensor package that detects primary filter breakthrough of solvent and acid fumes, laboratory air quality, sash position and temperature. Audio/visual alarms alert you to filter breakthrough, fan failure, high sash position and high temperature, which could indicate fire.
- Intelligent filter indication of type and status (primary or secondary). RFID technology scans each filter's serial number preventing saturated filter re-installation.
- Optional gGuard® communication software that offers real time monitoring by a designated facility manager. From a remote location, data such as usage authorization, filter usage, filter saturation detection, sash position and temperature may be observed and managed.



### Neutrodine® Filters—the heart of GFH Filtration Technology

The Protector Echo uses Neutrodine Filters, the most comprehensive, safety-driven carbon filter available. This single molecular filter type can easily adsorb most chemicals and mixtures,



The Protector Echo Benchtop Filtered Fume Hood uses from four to ten Neutrodine Carbon Filters, depending on the hood's width. Two Neutrodine Filters are stacked in each filtration column. Optional HEPA Filters are available to handle applications involving both liquid and powder chemicals.

taking the guesswork out of filter selection. The Neutrodine Filter was tested and found efficient on over 500 chemicals, each at six or more concentrations. Because Neutrodine Filters allow the simultaneous handling of solvents, acids and bases, the Protector Echo may be used for a broad range of general chemistry fume hood applications.

### The Benefits of Protector Fume Hood Technology

Consistent among Protector Hoods, including the Echo, are several defining features that maximize containment and enhance user comfort.

- Patented\* Clean-Sweep™ Sash Handle and Sash Tracks that bleed air into the interior and away from the user's breathing zone. The slim-line radiused sash handle reduces turbulence.
- Patented\* Eco-Foil™ Air Foil with Clean-Sweep openings to pull inflow air into the hood in non-turbulent air streams. The curve of the foil is comfortable for arms resting on it.

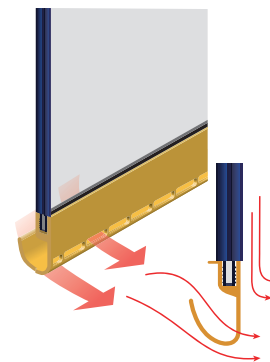

\*U.S. Patent No. 6,461,233



## Protector® Echo™ Filtered Fume Hoods

- Cord-Keeper™ Slots on the left and right side of the air foil that allow the sash to be closed completely when electrical cords are plugged into the side receptacles.
- Large, 37.5" high (95.3 cm) sightline that provides taller users comfortable viewing while standing without obstruction of hinges.
- Deep, 31" (78.7 cm) interior work space.
- Looks like a hood, acts like a hood. Consistent dimensions, features and functionality, such as fiberglass-reinforced panel liner, fully closing sash, electrical receptacles and service fixtures, makes usage seamless in laboratories with both ducted and filtered hoods.

### Easy to install, adaptable to changing lab spaces

Labconco factory installs the control panel on the front of the hood for ease of installation. The high capacity Neutrodine Filters, ordered separately from the hood, require initial set up, but may last two years or more before replacement is required.

Because the Protector Echo requires no connection to ductwork, initial building infrastructure change costs are minimized and allows the hood to be placed in hard-to-duct areas such as the center or bottom level of multi-level buildings. Should lab configurations change, the Protector Echo may be relocated without disrupting existing heating and air conditioning systems.

### Better for the environment, far less costly to operate

Unlike ducted hoods, costly tempered room air is not exhausted from the laboratory, resulting in energy savings. The Cost

Comparison Chart on page 5 shows the lower lifetime costs of a filtered hood compared to a traditional ducted hood in various configurations. The greatest savings of a filtered hood is illustrated by the make-up air cost—the Protector Echo has none! In addition, the Protector Echo eliminates air pollutant emissions into the atmosphere. The Neutrodine Filter is made of plant-based carbon materials impregnated with neutral non-toxic agents. Once expended, the filters may be incinerated for environmentally-safe disposal.

### Choose the right hood for you

The Protector Echo Filtered Fume Hood is available in widths from 4' to 8' and in benchtop and floor-mounted designs to fit your lab's space requirements and applications. Benchtop models are available with a fiberglass panelized liner, with optional side windows, or with optional side and back windows. To determine if your application is right for a Protector Echo, contact a Labconco specialist who can evaluate the list of chemicals used in your experiments and provide you with a recommendation.



*Protector Echo Benchtop Filtered Fume Hoods are available with optional side and back windows to provide enhanced visual access for demonstrations. The back window does not obstruct visibility when hoods are placed back-to-back in an island configuration. Protector Echo Hoods are also available with solid interior liners of panelized fiberglass or with side windows only.*



*Protector Echo Floor-Mounted Filtered Fume Hoods provide the interior height needed for bulky apparatus. These hoods feature fully-closing, vertical-rising sashes.*

Table 1.

### SEFA 9

SEFA 9 (Recommended Practices for Ductless Enclosures) defines three categories of "ductless hoods."

**DH I** - A ductless hood equipped with a filtration device designed to control non-toxic chemicals, nuisance odors and particulates.

**DH II** - A ductless hood capable of meeting all DH I requirements, and equipped with a filtration device designed to filter manufacturer-approved toxic contaminants to filter breakthrough only.

**DH III** - A ductless hood capable of meeting all DH II requirements, and equipped with a filtration device designed to filter manufacturer-approved toxic contaminants beyond primary filter breakthrough by providing secondary back-up protection.







## Protector® Echo™ Benchtop Filtered Fume Hoods



4' Protector Echo Filtered Fume Hood 180410002 is shown with SpillStopper Work Surface 9501400 and Protector Standard Storage Cabinet 9900000.

### All models feature:

- By-pass airflow design.
-  Eco-Foil™ Air Foil with aerodynamic Clean-Sweep™ airflow openings.\*
-  Cord-Keeper™ Slots on left and right side of air foil.
- Glacier white powder-coated steel exterior.
- Chemical-resistant, fiberglass-reinforced, composite panel liner.
-  Single piece, tempered safety glass vertical-rising sash with cable pulley, sash weight and powder-coated aluminum sash handle and tracks with Clean-Sweep™ airflow openings. Sash stop at 16" sash opening height. Sash opens to 28" high for loading.
- 37.5" (95.3 cm) high sightline from the work surface and header panel.
-  Removable front and side panels, and front and interior service access panels (except side window models) for access to plumbing and electrical wiring.
- Pre-wired vapor-proof fluorescent lighting providing up to 63 foot candles: 2 lights per 4' model, 3 lights per 5' model, 4 lights per 6' model, and 5 lights per 8' model.
- Factory-prepared for up to four electrical duplex receptacles and eight service fixtures.
- Factory-installed control panel with digital display, fan button and light button.
- Roughing prefilter, 2 each per 4' model, 3 each per 5' model, 4 each per 6' model, and 5 each per 8' model.
- Built-in exhaust fans: 2 each per 4' model, 3 each per 5' model, 4 each per 6' model, and 5 each per 8' model, to maintain 60 fpm face velocity at 16" sash opening height.
- Sound pressure of <60 dB(A) with sash at operating height and <48 dB(A) with sash closed.

- Sensor package for primary filter breakthrough of solvent and acid fumes, laboratory air quality, sash position, and temperature.
- Audible/visual alarms for breakthrough detection, temperature  $\geq 40^{\circ}\text{C}$  ( $104^{\circ}\text{F}$ ), fan failure and high sash position opening. At  $\geq 60^{\circ}\text{C}$  ( $140^{\circ}\text{F}$ ), all fans stop.
- Three radio frequency identification (RFID) cards included: 9580901 User Card, 9580900 Administrator Card, and 9580902 Maintenance Card. Additional cards available upon request.
- Power cord with plug. Or, may be hard wired to top-mounted boxes.

### Standards conformance and regulations\*\*:

- SEFA 9, DHIII
  - SEFA 8, Cabinet Surface Finish Tests
  - ASHRAE 110
  - ANSI Z9.5
  - AFNOR NF-X 15-211
  - ASTM E84-09C
  - UL 61010-1
  - CAN/CSA C22.2 No. 61010.1
- ▲ **WARNING:** Cancer - P65Warnings.ca.gov (California only)

### Side window models feature:

- Right and left side-mounted tempered safety glass windows, 15.0" x 26.5" (38.1 x 67.3 cm).

### Side and back window models feature:

- Right and left side-mounted tempered safety glass windows, 15.0" deep x 26.5" high (38.1 x 67.3 cm).
- Rear tempered safety glass window, 32.4" high (82.3 cm).

### Fixture models may feature:

- Two pre-plumbed service fixtures with forged brass valves, lower right side with brass tubing for gas and lower left side with copper tubing for cold water. Components for converting either or both fixtures to air and vacuum are provided. Inlet tubing is not provided.
- One pre-wired GFCI electrical duplex receptacle on lower right side and, on 8' models only, one additional pre-wired GFCI electrical duplex receptacle on the lower left side.

### Required (not included):

- Neutrodine Filters (see page 11).
- Work Surface (see page 7).
- Base Cabinet or Stand (contact Labconco).

### Optional accessories include (see pages 11-12):

- HEPA Filter.
- gGuard® Communication software.
- ADA Remote Control.
- Sash Opening Reduction Wing Kits.

Contact Labconco for ordering information on electrical duplex receptacles, service fixtures and other fume hood accessories.

\*U.S. Patent No. 6,461,233

\*\*See back cover for a list of regulations, standards and registered trademarks.

 Heights of switches and electrical receptacle, when work surface is set to ADA height, meet requirements of ADA.

 Exclusive Feature



## Ordering Information

### PROTECTOR® ECHO™ BENCHTOP FILTERED FUME HOODS

Use this key to configure the **nine digit catalog number** to order your Protector Echo Benchtop Filtered Fume Hood.

For example, a **180410002** is a 4' Protector Echo Benchtop Filtered Fume Hood with solid walls, with 100-115 volt, 50/60 Hz electrical requirements, two service fixtures and one GFCI electrical duplex receptacle. **NOTE: Neutrodine Filters are required for operation and sold separately. See page 11.**



**STEP 1.** Select the **wall configuration** of your fume hood. This number is the third digit of your catalog number.

- 0** = Solid walls, no windows    **1** = Side windows
- 2** = Side and back windows

**STEP 2.** Select the **width** of your fume hood. This number is the fourth digit of your catalog number. Shipping weight is noted for models without windows. Add 30 lbs. (14 kg) for models with side windows. Add 40 lbs. (18 kg) for models with side and back windows.

- 4** = 4' (122 cm)                      **6** = 6' (183 cm)
- 530 lbs. (240 kg)                      745 lbs. (338 kg)
- 5** = 5' (152 cm)                      **8** = 8' (244 cm)
- 655 lbs. (297 kg)                      985 lbs. (447 kg)

**STEP 3.** Select the **Electrical Requirements, Service Fixtures and GFCI Electrical Duplex Receptacle** combination you desire. These two numbers comprise the eighth and ninth digits of your catalog number. Add 10 lbs. (5 kg) for models with service fixtures.

Electrical Requirements/ Plug Type	No Service Fixtures	Two Service Fixtures	Two Service Fixtures & GFCI Duplex*
100-115 volts, 50/60 Hz, 10 amps  North America, 100-115 volts, 50/60 Hz, 10 amps; 8.5' cord	<b>00</b>	<b>01</b>	<b>02</b>
208-230 volts, 50/60 Hz, 5 amps  North America, 208-230 volts, 50/60 Hz, 5 amps; 6.5' cord	<b>20</b>	<b>21</b>	—

\*Hoods with GFCI electrical duplex are rated at 20 amps. 8' Hoods have two GFCI electrical duplex receptacles, one mounted on each side, 20 amps each.

## Cost Comparison: Traditional Ducted Fume Hood vs. Filtered Fume Hood

	Constant Volume By-Pass (CV)	Variable Air Volume (VAV)	Variable Air Volume High Perf. (VAV HP)	Filtered
6' Benchtop Fume Hood with vertical-rising sash <sup>1,2</sup>	\$14,500	\$14,500	\$16,200	\$31,900
Building Infrastructure: M-E-P, Lab Services & Data <sup>3</sup>	\$20,000	\$25,000	\$25,000	\$2,000
<b>Total Initial, One-Time Costs</b>	<b>\$34,500</b>	<b>\$39,500</b>	<b>\$41,200</b>	<b>\$33,900</b>
Energy Cost/Year				
Exhaust Fans <sup>4</sup>	\$1,367	\$911	\$711	\$293
Make-up Air (\$8/cfm) <sup>5</sup>	\$9,600	\$6,400	\$4,992	\$0
Maintenance Costs/Year <sup>6</sup>	\$1,200	\$1,500	\$1,500	\$1,800
<b>Total Operating &amp; Maintenance Costs/Year</b>	<b>\$12,167</b>	<b>\$8,811</b>	<b>\$7,203</b>	<b>\$2,093</b>

<sup>0</sup> Figures do not include potential savings due to reduced chiller capacity resulting in a lower chilled water load.

<sup>1</sup> Cost comparison is based on new construction and includes estimated 2015 costs per 6' fume hood with a vertical-rising sash configuration and utility connections including compressed air, lab vacuum, natural gas, electrical power and data. Costs for the CV, VAV and VAV HP include the remote blower. Cost for the Filtered Hood includes the first set of filters.

<sup>2</sup> National Grid and other local and national utility companies provide a first time equipment cost rebate of up to 70% of the difference in cost between a conventional constant volume by-pass hood and filtered fume hood. Energy rebate savings are not included in the figures above.

<sup>3</sup> Estimated building infrastructure cost (M-E-P Data) per fume hood based on new building construction with approximately 100 fume hoods.

<sup>4</sup> Estimated electrical energy costs per year per fume hood. Assumes fans operate 24 hours/day, 365 days/year, 8760 hours/year at \$0.12/kWh. Fan specified is 1 HP, 2" static pressure. Equivalent electrical load per NEC Article 430/full load current at 460 volts/3 phase/2.1 amps = 1.3 kWh.

<sup>5</sup> Estimated mechanical energy cost per year per fume hood: 6' CV (1,200 CFM x \$8.00/CFM/year=\$9,600), 6' VAV (800 CFM x \$8.00/CFM/year=\$6,400), 6' VAV HP (624 CFM x \$8.00/CFM/year=\$4,992).

<sup>6</sup> Maintenance costs for CV, VAV and VAV HP includes yearly certifications. Costs for Filtered Hood includes filter replacement.

Cost comparison data prepared by Ellensweig Architects in collaboration with BR+A Consulting Engineers, R.W. Sullivan Engineering and Vanderweil Engineers. Cost data was updated in 2015. The cost savings illustrated above do not take into account possible additional savings associated with a reduced floor to floor height related to possible reduced HVAC ductwork.



## Dimensional Data

### PROTECTOR® ECHO™ BENCHTOP FILTERED FUME HOODS

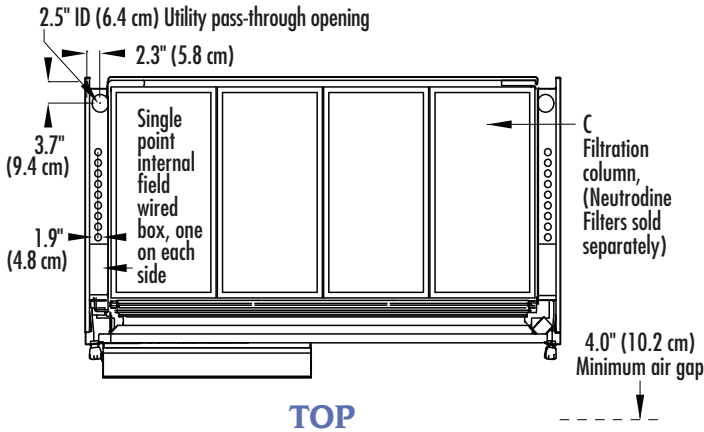

	A	B	C	D
4' Hood	48.0" (121.9 cm)	38.2" (97.0 cm)	2 ea	27.9" (70.9 cm)
5' Hood	60.0" (152.4 cm)	50.2" (127.5 cm)	3 ea	36.9" (93.7 cm)
6' Hood	72.0" (182.9 cm)	62.2" (158.0 cm)	4 ea	49.9" (126.7 cm)
8' Hood	96.0" (243.8 cm)	86.2" (218.9 cm)	5 ea	66.9" (169.9 cm)

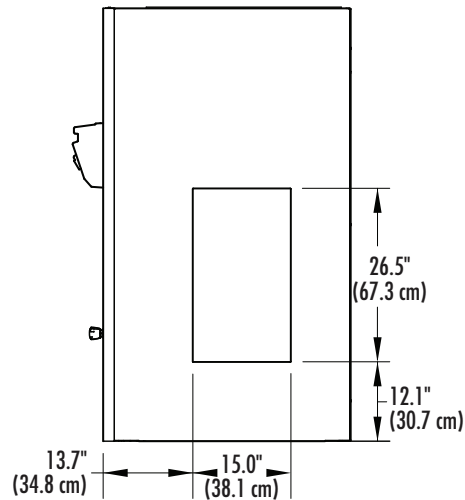
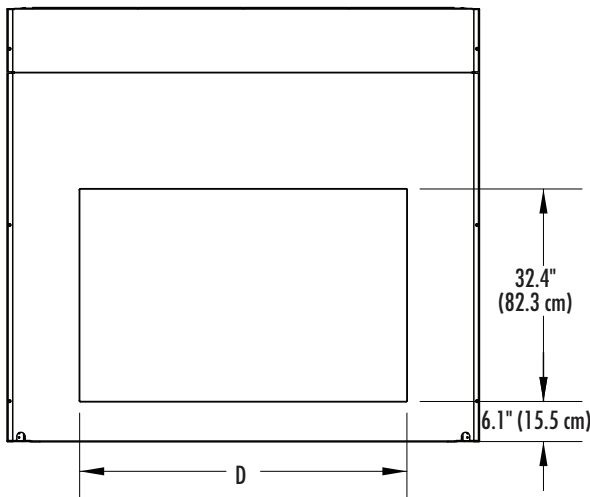
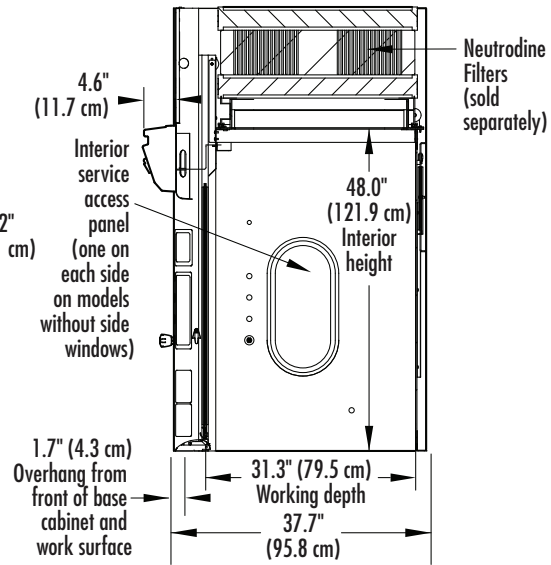
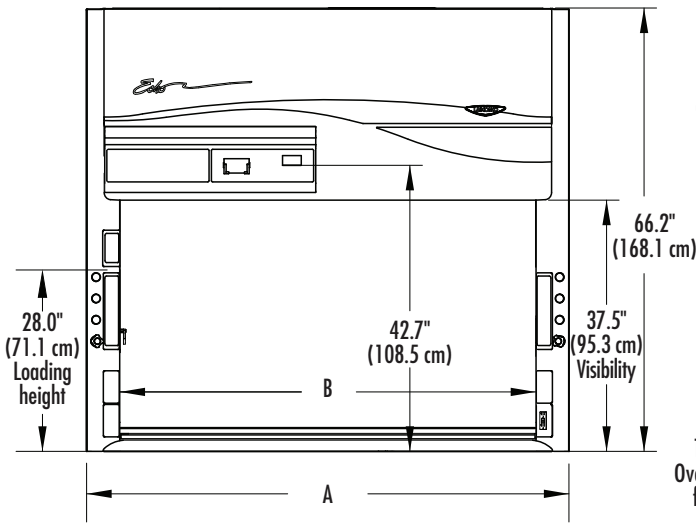



# SpillStopper™ Work Surfaces

Use this key to configure the **seven digit catalog number** to order your SpillStopper Dished Solid Epoxy Work Surface. For example, a **9501610** is a 6' wide x 36" deep SpillStopper Work Surface, with a left rear cupsink cutout.

**9**      **5**      **0**      **1**

**STEP 1.** Select the **nominal width** of your filtered fume hood. This number is the fifth digit of your catalog number. Shipping weight is noted for each width.

- |                  |                   |
|------------------|-------------------|
| <b>4</b> = 4'    | <b>6</b> = 6'     |
| 120 lbs. (54 kg) | 220 lbs. (100 kg) |
| <b>5</b> = 5'    | <b>8</b> = 8'     |
| 160 lbs. (73 kg) | 250 lbs. (113 kg) |

**STEP 3.** Select a **left cupsink cutout** option (cupsink is sold separately). See dimensional drawing. This number is the sixth digit of your catalog number.

Left Cupsink Cutout	
<b>0</b>	None
<b>1</b>	Rear
<b>2</b>	Side*

**STEP 4.** Select a **right cupsink cutout** option (cupsink is sold separately). See dimensional drawing. This number is the seventh digit of your catalog number.

Right Cupsink Cutout	
<b>0</b>	None
<b>1</b>	Rear
<b>2</b>	Side*

\*Not compatible with Protector Solvent Storage Cabinets.

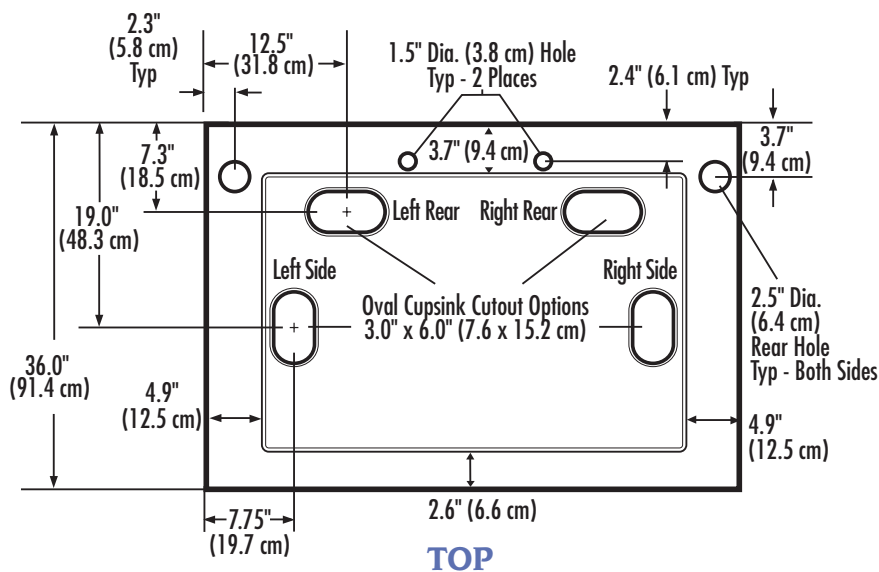

**4005200 Oval Polypropylene Cupsink**  
Mounts in work surface with cupsink cutout, 3.0" x 6.0" (7.6 x 15.2 cm). 1.5" (5.8 cm) National Pipe Straight Mechanical (NPSM) thread. Shipping weight 4 lbs. (2 kg)

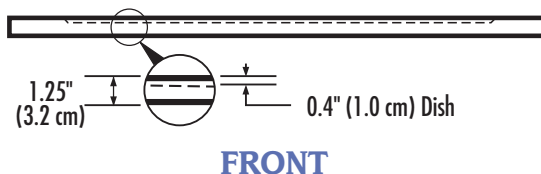

Contact Labconco for information on base cabinets and stands.



## Protector® Echo™ Floor-Mounted Filtered Fume Hoods



6' Protector Echo Floor-Mounted Filtered Fume Hood 183617002.

### All models feature:

- By-pass airflow design.
- Glacier white powder-coated steel exterior.
- Chemical-resistant, fiberglass-reinforced, composite panel liner and baffle.
- Opti-Zone™ Baffles\*, removable for cleaning.
- Two tempered safety glass vertical-rising sashes with powder-coated aluminum sash handles and powder-coated steel sash tracks with Clean-Sweep™ slots. Upper sash handle also includes Clean-Sweep™ openings.\* Sash stop at 52" from the floor.
- 73.5" (187 cm) high sightline from the floor to the header panel.
- 63.6" (162 cm) loading height.
- Removable front and side panels, and front and interior service access panels for access to plumbing and electrical wiring.
- Pre-wired vapor-proof fluorescent lighting providing up to 63 foot candles: 2 lights per 4' model, 3 lights per 5' model, 4 lights per 6' model, and 5 lights per 8' model.
- Factory-prepared for up to four electrical duplex receptacles and eight service fixtures.
- Factory-installed control panel with digital display, fan button and light button.
- Roughing prefilter, 2 each per 4' model, 3 each per 5' model, 4 each per 6' model, and 5 each per 8' model.

- Built-in exhaust fans: 2 each per 4' model, 3 each per 5' model, 4 each per 6' model, and 5 each per 8' model to maintain 60 fpm face velocity at 52" sash opening height.
- Sound pressure of <60 dB(A) with sash at operating height and <48 dB(A) with sash closed.
- Sensor package for primary filter breakthrough of solvent and acid fumes, laboratory air quality, sash position, and temperature.
- Audible/visual alarms for breakthrough detection, temperature  $\geq 40^{\circ}\text{C}$  ( $104^{\circ}\text{F}$ ), fan failure and high sash position opening. At  $\geq 60^{\circ}\text{C}$  ( $140^{\circ}\text{F}$ ), all fans stop.
- Three radio frequency identification (RFID) cards included: 9580901 User Card, 9580900 Administrator Card, and 9580902 Maintenance Card. Additional cards available upon request.
- Power cord with plug. Or, may be hard wired to top-mounted boxes.
- Shipped in multiple sections: top, bottom and sashes.

### Standards conformance and regulations\*\*:

- SEFA 9, DHIII
  - SEFA 8, Cabinet Surface Finish Tests
  - ASHRAE 110
  - ANSI Z9.5
  - AFNOR NF X 15-211
  - ASTM E84-09C
  - UL 61010-1
  - CAN/CSA C22.2 No. 61010.1
- ⚠ **WARNING:** Cancer - P65Warnings.ca.gov (California only)

### Fixtured models feature:

- Two pre-plumbed service fixtures with forged brass valves, lower right side with brass tubing for gas and lower left side with copper tubing for cold water. Components for converting either or both fixtures to air and vacuum are provided. Inlet tubing is not provided.
- One pre-wired GFCI electrical duplex receptacle on lower right side and, on 8' models only, one additional pre-wired GFCI electrical duplex receptacle on the lower left side.

### Required (not included):

- Neutrodine Filters (see page 11).

### Optional accessories include (see pages 11-12):

- HEPA Filter.
- gGuard® Communication software.
- ADA Remote Control.
- Sash Opening Reduction Wing Kits.

Contact Labconco for ordering information on electrical duplex receptacles, service fixtures and other fume hood accessories.

\*U.S. Patent No. 6,461,233

\*\*See back cover for a list of regulations, standards and registered trademarks.



Heights of switches and electrical receptacle when work surface is set to ADA height meet requirements of Americans with Disabilities Act.



Exclusive Feature





## Ordering Information

### PROTECTOR® ECHO™ FLOOR-MOUNTED FILTERED FUME HOODS

Use this key to configure the **nine digit catalog number** to order your Protector Echo Floor-Mounted Filtered Fume Hood. For example, a **183417002** is a 4' Protector Echo Floor-Mounted Filtered Fume Hood, with 100-115 volt, 50/60 Hz electrical requirements, two service fixtures and one GFCI electrical duplex receptacle. **NOTE: Neutrodine Filters are required for operation and sold separately. See page 11.**

**1**      **8**      **3**      **7**      **0**

**STEP 1.** Select the **width** of your fume hood. This number is the fourth digit of your catalog number.

**4** = 4' (122 cm)      **6** = 6' (183 cm)  
**5** = 5' (152 cm)      **8** = 8' (244 cm)

**STEP 2.** Select the **exterior depth** of your fume hood. This number is the fifth digit of your catalog number.

**1** = 37.7" (95.8 cm)      **3** = 55.7" (141.5 cm)  
**2** = 43.7" (111.0 cm)

**STEP 3.** Select the **Electrical Requirements, Service Fixtures** and **GFCI Electrical Duplex Receptacle** combination you desire. These two numbers comprise the eighth and ninth digits of your catalog number.

Electrical Requirements/ Plug Type	No Service Fixtures	Two Service Fixtures	Two Service Fixtures & GFCI Duplex*
100-115 volts, 50/60 Hz, 10 amps  North America, 100-115 volts, 50/60 Hz, 10 amps; 8.5' cord	<b>00</b>	—	<b>02</b>
208-230 volts, 50/60 Hz, 5 amps  North America, 208-230 volts, 50/60 Hz, 5 amps; 6.5' cord	<b>20</b>	<b>21</b>	—

\*Hoods with GFCI electrical duplex are rated at 20 amps. 8' Hoods have two GFCI electrical duplex receptacles, one mounted on each side, 20 amps each.

### Shipping Weights

Hood Width	Description	37.7" Hood Depth	43.7" Hood Depth	55.7" Hood Depth
4'	No Service Fixtures	730 lbs. (331 kg)	745 lbs. (338 kg)	775 lbs. (352 kg)
4'	Two Service Fixtures	740 lbs. (336 kg)	755 lbs. (342 kg)	785 lbs. (356 kg)
5'	No Service Fixtures	955 lbs. (433 kg)	970 lbs. (440 kg)	1000 lbs. (454 kg)
5'	Two Service Fixtures	970 lbs. (440 kg)	985 lbs. (447 kg)	1015 lbs. (460 kg)
6'	No Service Fixtures	1080 lbs. (490 kg)	1135 lbs. (515 kg)	1165 lbs. (528 kg)
6'	Two Service Fixtures	1095 lbs. (497 kg)	1150 lbs. (522 kg)	1180 lbs. (535 kg)
8'	No Service Fixtures	1420 lbs. (644 kg)	1435 lbs. (651 kg)	1465 lbs. (665 kg)
8'	Two Service Fixtures	1435 lbs. (651 kg)	1450 lbs. (658 kg)	1480 lbs. (671 kg)



## Dimensional Data

### PROTECTOR® ECHO™ FLOOR-MOUNTED FILTERED FUME HOODS

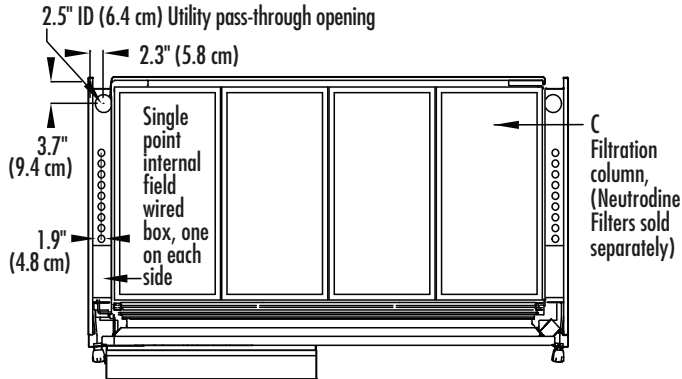

TOP

	A	B	C
4' Hood	48.0" (121.9 cm)	38.2" (97.0 cm)	2 ea
5' Hood	60.0" (152.4 cm)	50.2" (127.5 cm)	3 ea
6' Hood	72.0" (182.9 cm)	62.2" (158.0 cm)	4 ea
8' Hood	96.0" (243.8 cm)	86.2" (218.9 cm)	5 ea

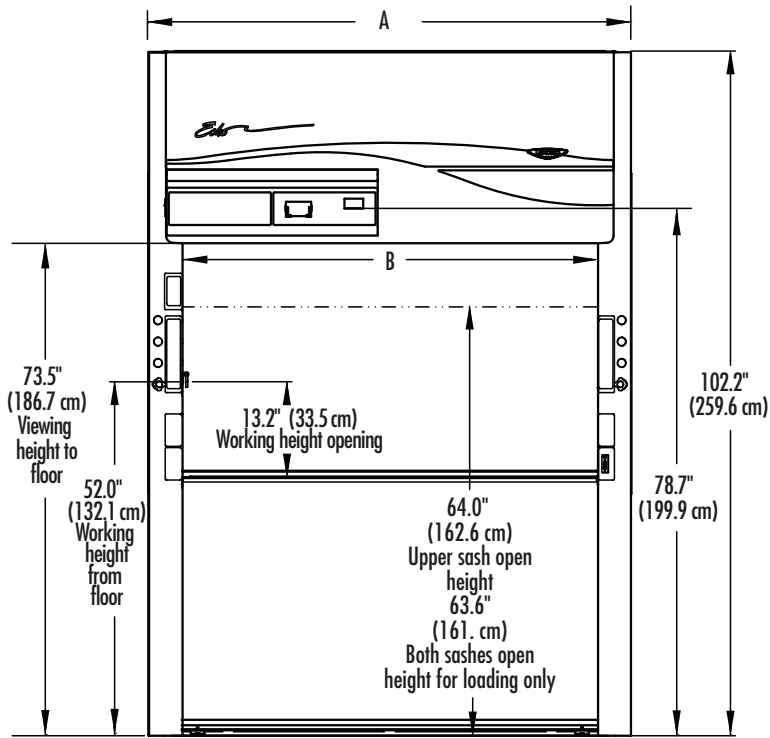

FRONT

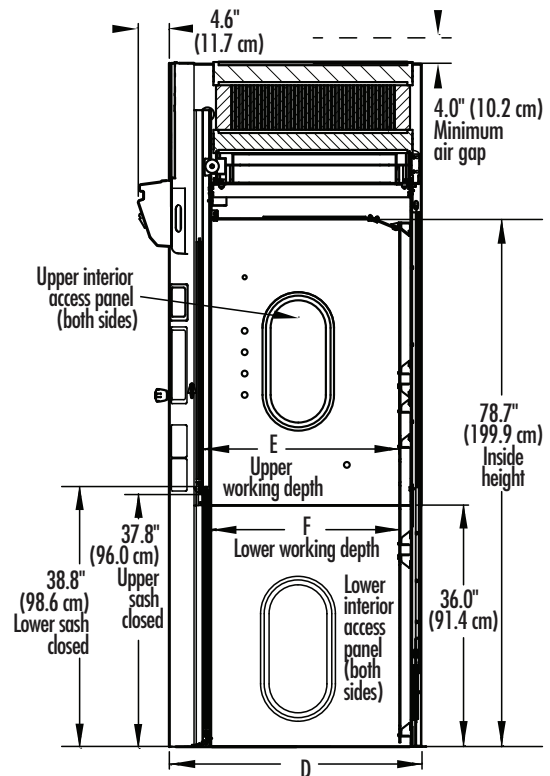

SIDE

D	E	F
37.7" (95.8 cm)	29.7" (75.4 cm)	28.7" (72.9 cm)
43.7" (111.0 cm)	35.7" (90.7 cm)	34.7" (88.1 cm)
55.7" (141.5 cm)	47.7" (121.2 cm)	46.7" (118.6 cm)



## Neutrodine® Filters by Erlab®

The Neutrodine Filter is a comprehensive molecular filter that allows the simultaneous handling of solvents, acids, bases, ammonia and formaldehyde. Neutrodine Filters don't simply filter the molecules, they transform them! Erlab scientists view filtration technology from a different perspective—it's not just about the carbon. Neutrodine filters utilize multiple layers of technology to transform molecules, allowing the simultaneous adsorption of solvents, acids, and bases. Each filter is designed with a unique filter frame that prevents carbon shifting and channeling which significantly extends the lifetime of the filter providing a high retention capacity for an unprecedented level of safety and operating cost savings.

In addition, for each filtration column, two filters are stacked: one main level plus one safety back-up level. Once breakthrough is detected in the main filter indicating saturation, the safety back-up filter may be moved to the main level and a new safety back-up filter installed. This revolving filter system minimizes filter replacement requirements and optimizes main filter lifetime, thereby saving money and reducing environmental impact.

### Revolving Filter System

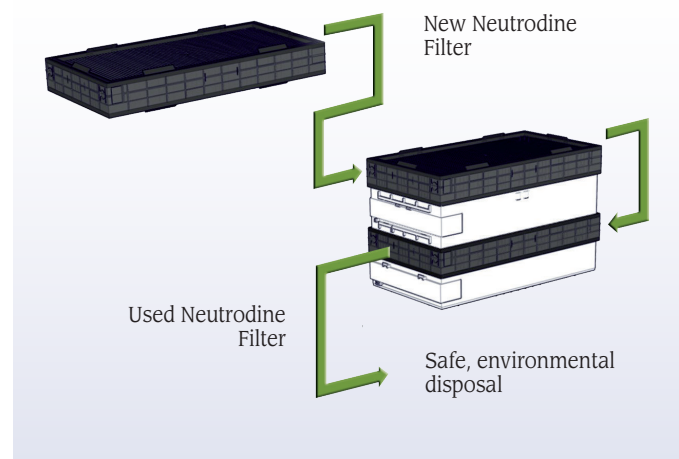

Hood Width	Filter Columns	Required No. of Neutrodine Filters	Replacement No. of Main Level Neutrodine Filters	Total Neutrodine Filter Media Weight*	Optional No. of HEPA Filters	Total HEPA Filter Weight
4'	2	4	2	100 lbs.	2	20 lbs.
5'	3	6	3	150 lbs.	3	30 lbs.
6'	4	8	4	200 lbs.	4	40 lbs.
8'	5	10	5	250 lbs.	5	50 lbs.
		<i>Initial order quantity of Cat. #9577400</i>	<i>Replacement order quantity of Cat. #9577400</i>		<i>Initial and replacement order quantity of Cat. # 9577401</i>	

### Typical Filtration Column Configuration

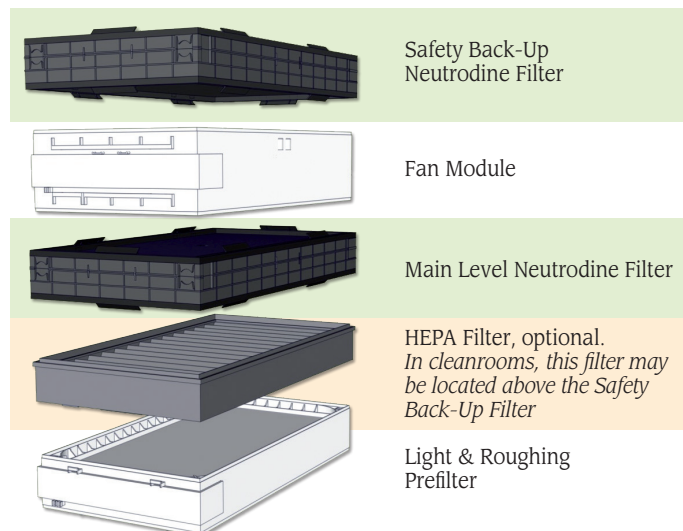

### Ordering Information

Catalog #	Description	Shipping Wt.
<b>9577400</b>	Neutrodine Filter, molecular carbon, 1 each	35 lbs. (16 kg)
<b>9577401</b>	HEPA Filter, 99.995% efficient, H14 type, 1 each	25 lbs. (11 kg)
<b>9577402</b>	Replacement Roughing Prefilter, located in light box, 1 each	5 lbs. (2 kg)
<b>9577403</b>	Replacement Acid Sensor, required every two years	5 lbs. (2 kg)
<b>9577700</b>	Replacement Light Bulb	5 lbs. (2 kg)

\*Filter media in the total number of filters required for operation per hood width.



## Accessories

### 9581100 gGuard® Communication Software

Automatically collects and records hood data, alerts and alarms on a customer-supplied personal computer. Monitors, manages and provides data via email to a designated facility manager. Provides access to the following: usage authorization, filter usage, Neutrodine Filter saturation detection, filter identification, sash position, blower speed, laboratory air pollution detection, temperature and usage statistics. Software available on USB flash drive. PC requirements include Windows 7 or newer operating system; x86 (32 bits)/x64 (64 bits)/ia64; Processor x86 - 1 Gb or more, 512 Mb min x 64 - 1, 4Gb or more; 850 Mb + 5 Gb free memory hard disk for the SQL database (x86 processor) or 2 Gb + 5 Gb free memory hard disk for the SQL database (x64 processor); 32 bits graphic card, 10/100/1000 Mbps ethernet card; and USB port. Shipping weight 0.5 lb. (0.2 kg)

### 9579700 ADA\* Remote Control

Allows persons in wheelchairs and/or shorter individuals to access the fan and light switches through a wireless remote control. Shipping weight 1 lb. (0.5 kg)



\*Americans with Disabilities Act

### Sash Opening Reduction Wing Kits

Wings reduce the sash opening area to increase face velocity at the 16" sash stop position from 60 fpm to 100 fpm. Hinged with detents to maintain open position for loading and closed position for normal operation. For use with Protector Echo Benchtop and Floor-Mounted Filtered Fume Hoods. Contact Labconco for ordering information on optional accessory airflow monitors. Shipping weight 5 lbs. (2 kg)

Catalog Number	For Use with:	Sash Opening (w x h)	Face Velocity (fpm)	Sash Wing Width
9584904	4' Protector Echo	18" x 16"	100	10"
9584905	5' Protector Echo	26" x 16"	100	12"
9584906	6' Protector Echo	34" x 16"	100	14"
9584908	8' Protector Echo	48" x 16"	100	19"

Contact Labconco for ordering information on BACnet™ Gateway Hardware and other fume hood accessories.

## Standards

Key aspects of standards and codes as they relate to filtered fume hoods are summarized below.

### AFNOR NF X 15-211

Imposes performance criteria for Class 1 and 2 filtration fume hoods

- Class I - Filtration fume hood has safety reserve filtration level, filter exhaust must be lower than 1% of the TLV, containment threshold of 0.1 ppm of SF6 gas measured in grids at the face of the hood, booklet containing exhaustive list of compatible chemicals

### AFNOR Group

www.afnor.org/en

### ASHRAE 110 Method of Testing Performance of Laboratory Fume Hoods (ANSI Approved)

Evaluates fume hood's containment characteristics.

- Three part test: Smoke generation, face velocity profile, tracer gas release @ 4 liters per minute.
- Rated As Manufactured (AM), As Installed (AI) and As Used (AU).

### American Society of Heating, Refrigerating and Air-Conditioning Engineers

www.ashrae.org

### ANSI Z9.5 Standard—Laboratory Ventilation

Covers entire laboratory ventilation system.

- New and remodeled hoods shall have a monitoring device.
- Ductless hoods should only be used with non-hazardous materials.

### American Industrial Hygiene Association

www.aiha.org

### ASTM E84-09C Standard Test Method for Surface Burning Characteristics of Building Materials

Determines the relative burning behavior of the material by observing the flame spread along the specimen.

- Measures the flame spread and smoke development.
- Material is exposed to flaming fire for 10 minutes and the results measured and recorded.
- Results are compared to the indexes of mineral fiber cement board (flame spread and smoke development of zero) and red oak flooring (smoke development of 100).

### ASTM International

www.astm.org

### SEFA 9 Recommended Practices for Ductless

### Enclosures

- Defines three categories of ductless hoods, DH I, DH 2 and DH3, each category adding to the capabilities of the previous category
- DH III is equipped with a filtration device that filters toxic contaminants beyond primary filter breakthrough via secondary back up protection

### SEFA 8 Recommended Practices For Metal Laboratory Grade Furniture, Casework, Shelving and Tables, 8.0 Cabinet Surface Finish Tests

Defines test methods for evaluating the finish of laboratory furniture.

- Laboratory grade paint finishes shall withstand chemical exposure, hot water, and impact from a one-pound ball dropped from 12".
- Paint coating shall sufficiently adhere to the substrate.
- Paint shall be resistant to scratches.

### Scientific Equipment & Furniture Association

www.sefalabs.com

### UL 61010-1 Electrical Equipment for Laboratory Use

Specifies the general safety requirements for electrical equipment.

- Based on International Electrotechnical Commission (IEC) Publication 61010-1 with differences noted for U.S. use.
- Tests for protection against electrical shock, mechanical hazards, spread of fire, radiation, liberated gases, explosion and implosion.
- Tests for resistance to shock, vibration, impact, heat, moisture and liquids.

### Underwriters Laboratories Inc.

www.ul.com

### CAN/CSA Standard C22.2 No. 1010.1 Safety Requirements for Electrical Equipment for Measurement, Control and Laboratory Use

Specifies general safety requirements for electrical equipment.

- Design and methods of construction should provide adequate protection to the operator and the surrounding area against shock or burn, mechanical hazards, excessive temperature, spread of fire from the equipment, gas liberation, explosion or implosion.

### Canadian Standards Association

www.csa.ca

### ETL listing

ETL Testing Laboratories is a Nationally Recognized Testing Laboratory (NRTL). The ETL mark signifies that a product conforms to the following:

- UL Standard 61010-1 in the U.S.
- CAN/CSA Standard C22.2 No. 61010.1 in Canada.
- Products that bear the ETL mark are subjected to a comprehensive safety program that includes testing, listing, labeling and quarterly follow-up inspections.

### Intertek Group

www.intertek.com

### CE Marking

Indicates an electrical apparatus conformity to all safety and other directives/specifications presently required by the Council of European Communities.

- Electrical safety.
- Electromagnetic emissions testing—interference signals being output by the product.
- Electromagnetic immunity testing—the product does not respond to outside electromagnetic interference signals.

### European Union

www.europa.eu

## Registered Trademarks

AFNOR® is a registered trademark of AFNOR Group.

ANSI® is a registered trademark of American National Standards Institute.

BACnet™ is a trademark of ASHRAE.

GreenFumeHood®, Neutrodine® and gGuard® are registered trademarks of Erlab®.

SEFA® is a registered trademark of Scientific Equipment and Furniture Association.

UL® is a registered trademark of UL, LLC.



### Labconco Corporation

8811 Prospect Avenue, Kansas City, MO 64132-2696

800-821-5525 or 816-333-8811

FAX 816-363-0130, www.labconco.com

