



LABCONCO CORPORATION
8811 Prospect Avenue
Kansas City, MO 64132
(800) 821-5525, (816) 333-8811
(816) 363-0130 fax
labconco@labconco.com

User's Manual

Protector[®] Echo[™] & Protector[®] Airo[™] Filtered Fume Hoods

Models

- 180 Series – 4', 5', 6' and 8' (Echo)
- 181 Series – 4', 5', 6' and 8' with side glass (Echo)
- 182 Series – 4', 5', 6' and 8' with 360 degree visibility (Echo)
- 183 Series – 4', 5', 6' and 8' Floor-Mount only (Echo)
- 184 Series – 3' and 4' small height models only (Airo)

To receive important product updates,
complete your product registration card
online at register.labconco.com

Please read the User's Manual before operating the equipment.

Copyright © 2018 Labconco Corporation. The information contained in this manual and the accompanying products are copyrighted and all rights reserved by Labconco Corporation. Labconco Corporation reserves the right to make periodic design changes without obligation to notify any person or entity of such change.

Warranty

Labconco Corporation provides a warranty to the original buyer for the repair or replacement of parts and reasonable labor as a result of normal and proper use of the equipment with compatible chemicals. Broken glassware and maintenance items, such as filters, gaskets, light bulbs, finishes and lubrication are not warranted. Excluded from warranty are products with improper installation, erratic electrical or utility supply, unauthorized repair and products used with incompatible chemicals.

The warranty for Protector® Echo™ & Protector® Airo™ Filtered Fume Hoods will expire one year from date of installation or two years from date of shipment from Labconco, whichever is sooner. Warranty is non-transferable and only applies to the owner (organization) of record.

Buyer is exclusively responsible for the set-up, installation, verification, decontamination or calibration of equipment. This limited warranty covers parts and labor, but not transportation and insurance charges. If the failure is determined to be covered under this warranty, the dealer or Labconco Corporation will authorize repair or replacement of all defective parts to restore the unit to operation. Repairs may be completed by 3rd party service agents approved by Labconco Corporation. Labconco Corporation reserves the rights to limit this warranty based on a service agent's travel, working hours, the site's entry restrictions and unobstructed access to serviceable components of the product.

Under no circumstances shall Labconco Corporation be liable for indirect, consequential, or special damages of any kind. This warranty is exclusive and in lieu of all other warranties whether oral, or implied.

Returned or Damaged Goods

Do not return goods without the prior authorization from Labconco. Unauthorized returns will not be accepted. If your shipment was damaged in transit, you must file a claim directly with the freight carrier. Labconco Corporation and its dealers are not responsible for shipping damages.

The United States Interstate Commerce Commission rules require that claims be filed with the delivery carrier within fifteen (15) days of delivery.

Limitation of Liability

The disposal and/or emission of substances used in connection with this equipment may be governed by various federal, state, or local regulations. All users of this equipment are required to become familiar with any regulations that apply in the user's area concerning the dumping of waste materials in or upon water, land, or air and to comply with such regulations. Labconco Corporation is held harmless with respect to user's compliance with such regulations.

Contacting Labconco Corporation

If you have questions that are not addressed in this manual, or if you need technical assistance, contact Labconco's Customer Service Department or Labconco's Product Service Department at 1-800-821-5525 or 1-816-333-8811, between the hours of 7:30 a.m. and 5:30 p.m., Central Standard Time.

TABLE OF CONTENTS

CHAPTER 1: INTRODUCTION	1
Model Number Configurator	2
About This Manual	3
Typographical Conventions	4
Your Next Step	5
CHAPTER 2: PREREQUISITES	6
Location Requirements	7
Support Requirements	7
Filtration Technology Airflow and Power Requirements	7
Electrical Requirements	8
Service Line Requirements	8
Space Requirements	8
Commissioning, Setup and Startup Requirements	8
CHAPTER 3: GETTING STARTED	9
Unpacking Your Fume Hood	10
Removing the Shipping Skid	10
Sash Weight Release	11
Installing the Hood on a Supporting Structure and Work Surface	11
Connecting the Electrical Supply Source to the Protector Hood	13
Connecting the Service Lines to the Protector Hood	15
Sealing the Protector Hood to the Work Surface	16
Setting up the Protector Echo Floor-Mounted Filtered Hood	16
Commissioning the Filtration Technology	17
Re-Configuration Process	27
Troubleshooting Guide for GFH	43
Certifying the Protector Filtered Fume Hood	46
CHAPTER 4: PERFORMANCE FEATURES AND SAFETY PRECAUTIONS	
Performance Features	47
Safety Precautions	51

CHAPTER 5: USING THE PROTECTOR FILTERED HOOD	59
Access Cards	59
Starting the Filtered Hood	60
Operating the Vertical-Rising Sash	60
The Modular Neutrodine Filtration	60
Detecting a Breakthrough	61
Communication	63
User Options and Approved Chemicals	64
Working in Your Protector Filtered Fume Hood	64
CHAPTER 6: MAINTAINING THE PROTECTOR FILTERED HOOD	66
Routine Maintenance Schedule	66
Initial Certification	67
Re-Certification	67
User Alarm Code List	67
Tool List	70
Neutrodine SDS for Disposal	71
Partial Filter Replacement Procedure	73
Reconfiguration Process	87
Light and/or Circuit Board Replacement	88
Fan and/or Circuit Board Replacement	90
Fan Box Replacement	92
Electro (Acid) Sensor Replacement	95
Secure Mode	103
gGuard Checklist and Software Option	104
BACnet Checklist Option	104
CHAPTER 7: ACCESSORIZING THE PROTECTOR FILTERED HOOD	105
Filters	105
Work Surfaces	106
Base Stands, Accessory Shelves, Seismic Supports, and Hydraulic Lift Base Stands	107
Storage Cabinets	108
Installing Additional Service Fixtures	108
Installing an Electrical Duplex Outlet	110
Installing Optional Guardian™ Digital Airflow Monitor	111
Sash Stop Kit – Field Installation	111
Distillation Grids – Field Installation	112
Installing Remote Monitoring Software	112
Installing BACnet Gateway Hardware	113
ADA Remote Control	113
Additional User, Maintenance, and Administrator Access Cards	113
Sash Reduction Wing Kits	114
CHAPTER 8: TROUBLESHOOTING	115

APPENDIX A: PROTECTOR FILTERED HOOD REPLACEMENT COMPONENTS	118
Protector Echo Filtered Hood Replacement Parts	118
Neutrodine Filtration Technology Replacement Parts	119
APPENDIX B: PROTECTOR FILTERED HOOD DIMENSIONS	122
APPENDIX C: PROTECTOR FILTERED HOOD SPECIFICATIONS	125
APPENDIX D: SERIAL NUMBER TAG DESCRIPTION	127
APPENDIX E: gGUARD	133
APPENDIX F: BACnet	148
APPENDIX G: SECURE MODE	151
APPENDIX H: CHEMICAL GUIDE	155
APPENDIX I: REFERENCES	171
APPENDIX J: SETTING UP THE PROTECTOR ECHO FLOOR-MOUNTED FILTERED HOOD	173
APPENDIX K: SMALL 54.2" HEIGHT AIRO DIMENSIONS	185

CHAPTER 1

INTRODUCTION

Congratulations on your purchase of a Labconco Protector[®] Echo[™] or Protector[®] Airo[™] Filtered Fume Hood which is unique as it is built on a traditional fume hood platform along with Neutrodine[®] Filters that handle solvents, acids, and bases with one comprehensive filter. From here on in this manual, the Protector Airo only refers to the shorter height 3' and 4' widths with 54.2" exterior height. It offers a comfortable workspace for users accustomed to the space and utility of a standard ducted fume hood, but in the realm of a filtered fume hood. The Protector Filtered Fume Hood solves the problem of ducting in laboratories that are difficult to vent because of location. The Protector Filtered Fume Hood combines its patented (U.S. Patent No. 6,461,233) fully featured, containment-enhancing fume hood design with Neutrodine (by Erlab) filtration technology to deliver a multi-use ductless fume hood. The Protector Filtered Fume Hood meets the definition of SEFA 9 DH3 ductless hoods because of its sensor package, backup filters, and communication. Building communication is one of the most important aspects of the Protector Filtered Fume Hood. In the event of loss of airflow, damage of a primary filter, or if a leak reaches the second set of redundant filters for any reason, an alarm will sound and the communication system will alert a designated email address. The designated safety officer could be made aware of the problem immediately through any internet-enabled smart phone, tablet or computer. Large laboratories and labs where a single safety manager must handle multiple concerns will benefit most from this proactive safety system.

The Labconco Protector Filtered Fume Hood has been engineered to provide maximum visibility in a laboratory, and effectively contain toxic, noxious, or other harmful materials when properly installed. The Protector Filtered Fume Hood offers many unique features to enhance safety, performance, and visibility. To take full advantage of them, please acquaint yourself with this manual and keep it handy for future reference. If you are unfamiliar with how fume hoods operate, please review *Chapter 4: Performance Features and Safety Precautions* before you begin working in the fume hood. Even if you are an experienced fume hood user, please review *Chapter 5: Using Your Protector Filtered Hood*, which describes your filtered hood's features so that you can efficiently use the hood.



Figure 1-1

Model Number Configurator

Example:

1 8 0 4 1 0 0 0 2

Product Line	Family	Configuration	Width	Depth	Airfoil	Sash System	Electrical	Accessories						
Fume Hood	1 Filtered Hood	8	BT None	0 4' 4	37.7" BT & FM	1	Eco-Foil	0	Cable	0	115V	0	None	0
			BT Sides	1 5' 5	43.7" FM	2	Flush (Special)	4	Chain BT only	1	230V	2	2 Fixtures	1
			BT 360	2 6' 6	55.7" FM	3	None-FM only	7	(Special)				2 Fix & 1 GFCI	2
			FM None	3 8' 8									(8'-2 GFCI)	
			Airo/BT Small	4 3' 3	31.7" BT,	0								
			Height		small 3' only									
					Airo									

BT= Benchtop
FM= Floor Mount

About This Manual

This manual is designed to help you learn how to install, use, and maintain your filtered fume hood. Instructions for installing optional equipment on your hood are also included.

Chapter 1: Introduction provides a brief overview of the filtered fume hood, explains the organization of the manual, and defines the typographical conventions used in the manual.

Chapter 2: Prerequisites explains what you need to do to prepare your site before you install your filtered fume hood. Electrical and service requirements are discussed.

Chapter 3: Getting Started contains the information you need to properly unpack, inspect, install, and certify your filtered fume hood.

Chapter 4: Performance Features and Safety Precautions explains how the Protector Filtered Hood operates and the appropriate precautions you should take when using the fume hood.

Chapter 5: Using Your Protector Filtered Hood discusses the basic operation of your filtered fume hood. Information on how to prepare, use and shut down your Protector Filtered Hood are included.

Chapter 6: Maintaining Your Protector Filtered Hood explains how to perform routine maintenance on your filtered fume hood.

Chapter 7: Modifying Your Protector Filtered Hood explains how to modify the filtered fume hood or add accessories.

Chapter 8: Troubleshooting contains a table of problems you may encounter while using your filtered fume hood including the probable causes of the problems and suggested corrective actions.

Appendix A: Protector Filtered Hood Components contains labeled diagrams of all of the components of the filtered fume hoods.

Appendix B: Protector Filtered Hood Dimensions contains comprehensive diagrams showing all of the dimensions for the filtered fume hoods.

Appendix C: Protector Filtered Hood Specifications contains the electrical requirements for the filtered fume hood. Wiring diagrams are also included.

Appendix D: Serial Number Tag Description provides current rating code used on serial number tag.

Chapter 1: Introduction

Appendix E: gGuard

Appendix F: BACnet

Appendix G: Secure Mode

Appendix H: Chemical Guide

Appendix I: References lists the various resources available that deal with filtered fume hoods.

Typographical Conventions

Recognizing the following typographical conventions will help you understand and use this manual:

- Book, chapter, and section titles are shown in italic type (e.g., *Chapter 3: Getting Started*).
- Steps required to perform a task are presented in a numbered format.
- Comments located in the margins provide suggestions, reminders, and references.
- Critical information is presented in boldface type in paragraphs that are preceded by the exclamation icon. Failure to comply with the information following an exclamation icon may result in injury to the user or permanent damage to fume hood.
- Les informations critiques sont présentées en gras dans les paragraphes qui sont précédés par l'icône d'exclamation. Ne pas se conformer aux informations qui suivent une icône d'exclamation peut résulter à la blessure de l'utilisateur ou à des dommages irréversibles de la hotte aspirante.
- Critical information is presented in boldface type in paragraphs that are preceded by the wrench icon. These operations should only be performed by a trained certifier or contractor. Failure to comply with the information following a wrench icon may result in injury to the user or permanent damage to your hood.
- Les informations critiques sont présentées en gras dans les paragraphes qui sont précédés par l'icône de clé plate. Ces opérations devraient être seulement exécutées par un professionnel agréé. L'échec pour se conformer aux informations qui suivent une icône de clé plate peut résulter à la blessure de l'utilisateur ou à des dommages irréversibles de la hotte.
- Important information is presented in capitalized type in paragraphs that are preceded by the pointer icon. It is imperative that the information contained in these paragraphs be thoroughly read and understood by the user.

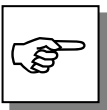



- CAUTION – See Manual. When this symbol is on a fume hood it indicates a caution that is detailed in this manual.
- PRUDENCE – Consulter le Manuel. Quand ce symbole est sur une hotte aspirante, il indique une prudence qui est détaillée dans ce manuel.

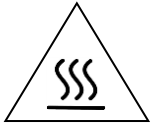

- CAUTION – Hot Surface
- AVERTIR – Surface Chaude



- CAUTION – See Manual. This symbol on the fume hood indicates the possibility of a pinch hazard.
- PRUDENCE – Consulter le Manuel. Ce symbole sur la hotte indique la possibilité d'un risque de pincement.

Your Next Step

If your Filtered Fume Hood needs to be installed, proceed to *Chapter 2: Prerequisites* to ensure your installation site meets all of the requirements. Then, go to *Chapter 3: Getting Started* for instructions on how to install your filtered fume hood and make all of the necessary connections.

If you would like to review how filtered fume hoods operate, go to *Chapter 4: Performance Features and Safety Precautions*.

For information on the operational characteristics of your filtered fume hood, go to *Chapter 5: Using Your Protector Filtered Hood*.

If your filtered fume hood is installed and you need to perform routine maintenance on the cabinet, proceed to *Chapter 6: Maintaining Your Protector Filtered Hood*.

For information on making modifications to the configuration of your fume hood, go to *Chapter 7: Modifying Your Protector Filtered Hood*.

Refer to *Chapter 8: Troubleshooting* if you are experiencing problems with your filtered fume hood.

CHAPTER 2

PREREQUISITES

Before you install your filtered fume hood, you need to prepare your site for installation. Carefully examine the location where you intend to install your hood. You must be certain that the area is level and of solid construction. In addition, a dedicated source of electrical power must be located near the installation site.

Carefully read this chapter to learn the requirements for your installation site:

- The location requirements.
- The support requirements.
- The Filtration Technology airflow and power requirements.
- The electrical power requirements.
- The service line requirements.
- The space requirements.
- The commissioning and setup requirements.

Refer to *Appendix B: Protector Filtered Hood Dimensions* for complete fume hood dimensions.

Refer to *Appendix C: Protector Filtered Hood Specifications* for complete filtered fume hood electrical and environmental conditions, specifications and requirements.

Location Requirements



The filtered fume hood should be located away from traffic patterns, doors, windows, fans, ventilation registers, and any other air-handling device that could disrupt its airflow patterns. All windows in the room should be closed.

La hotte filtrée devrait être situé loin des modèles de trafic, portes, fenêtres, ventilateurs, registres de ventilation, et tout autre dispositif de traitement de l'air qui pourraient perturber ses modèles de flux d'air. Toutes les fenêtres de la chambre doivent être fermés.

Support Requirements



ALL Protector Hood installations are usually permanent and stationary. The supporting structure usually consists of a base cabinet and chemically-resistant work surface. If needed, the Protector Hood may be placed on a cart or mobile bench.

Toutes les installations Protecteur de capot sont généralement permanent et stationnaire. La structure de support est généralement constitué d'une armoire de base et la surface de travail résistant aux produits chimiques. Si nécessaire, le Si nécessaire, le Protecteur du capot peut être placé sur un chariot ou un banc mobile.

Filtration Technology Airflow and Power Requirements

Hood width	Airflow (CFM)	Makeup Air (CFM)	Face Velocity (fpm)	No. of modules	Fan Power (watts)	Light Power (watts)	Total Power (watts)
3'	Up to 130	0, limited to min. volume required by local regulations and min. laboratory air change requirements.	60-100	1	36	18	54
4'	Up to 260		60-100	2	72	36	108
5'	Up to 390		60-100	3	108	54	162
6'	Up to 520		60-100	4	144	72	216
8'	Up to 650		60-100	5	180	90	270

Electrical Requirements

The Protector Filtered Hood models feature internal wiring for the fluorescent lights, fans, and control panel. All internal wiring is terminated with a simple plug in wall cord. The blower switch and light switch wires are part of the control panel. Refer to *Chapter 3: Getting Started* and *Appendix C: Protector Filtered Hood Specifications* for the wiring diagram for proper electrical installation.

Les modèles Protector Filtré capot disposent câblage interne pour les lumières, ventilateurs, et le panneau de contrôle fluorescent. Tout le câblage interne est terminé avec un simple plug-in cordon de mur. L'interrupteur de la soufflerie et fils de l'interrupteur de lumière font partie du panneau de contrôle. Reportez-vous au Chapitre 3: Mise en route et à l'Annexe C: Protector filtrée capot Spécifications pour le schéma de câblage pour l'installation électrique appropriée.

Service Line Requirements

All service lines to the filtered fume hood should be ¼ inch outside diameter, copper (brass for natural gas), and equipped with an easily accessible shut-off valve, should disconnection be required. Recommended operating pressure is 40 PSI, with a maximum allowable pressure of 200 PSI. Consider a pressure regulator to reduce line pressure to 40 PSI. Please check with local codes for other requirements.

Space Requirements

The dimensions for the different models are shown in *Appendix B: Protector Filtered Hood Dimensions*.

Commissioning, Setup and Startup Requirements

All commissioning for the Protector Filtered Hood requires installation, setup, startup and configuration of the Filtration Technology. Certifying the Protector Filtered Hood should be completed for final commissioning. Refer to *Chapter 3: Getting Started* for specifics on completing commissioning.

CHAPTER 3

GETTING STARTED

Now that the site for your filtered fume hood is properly prepared, you are ready to unpack, inspect, install, and certify your unit. Read this chapter to learn how to:

- Unpack and move your Protector Hood.
- Set up the filtered fume hood with the supporting structure and work surface.
- Connect the electrical supply source.
- Connect the service lines.
- Sealing the Protector Hood to the work surface.
- Commissioning the Filtration Technology.
- Re-configuration process (first time setup and replacing components).
- Arrange certification of your Protector Hood.

Depending upon which model you are installing, you may need common plumbing and electrical installation tools in addition to 5/16", 3/8", 7/16", and 1/2" wrenches, ratchets, sockets, a nut driver set, a flat-blade screwdriver, a Phillips screwdriver, and a carpenter level to complete the instructions in the chapter.



The Protector Hood models weigh between 400 to 835 lbs. (182-375 kg). The shipping skid allows for lifting with a mechanical lift truck or floor jack. If you must lift the fume hood manually, follow safe-lifting guidelines. Normally, the fume hood can be slid off a hydraulic lift table and be placed into position on top of the work surface. Do not lift by the front air foil.

Les modèles Protector capot pèsent entre 400 à 835 livres. (182 à 375 kg). La palette d'expédition permet de levage avec un chariot élévateur mécanique ou prise de parole. Si vous devez soulever la hotte manuellement, suivre les directives de sécurité-levage. Normalement, la hotte peut être glissé sur une table de levage hydraulique et être placé en position au-dessus de la surface de travail. Ne pas soulever par la feuille d'air avant.

Unpacking Your Fume Hood

Carefully remove the shrink-wrap or carton on your fume hood and inspect it for damage that may have occurred in transit. **All the filtration fans and lights are packaged in boxes on top of the hood liner and should not be discarded.** If your unit is damaged, notify the delivery carrier immediately and retain the entire shipment intact for inspection by the carrier.

The United States Interstate Commerce Commission rules require that claims be filed with the delivery carrier within fifteen (15) days of delivery.

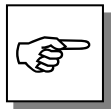

DO NOT RETURN GOODS WITHOUT THE PRIOR AUTHORIZATION OF LABCONCO. UNAUTHORIZED RETURNS WILL NOT BE ACCEPTED.

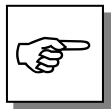

IF YOUR HOOD WAS DAMAGED IN TRANSIT, YOU MUST FILE A CLAIM DIRECTLY WITH THE FREIGHT CARRIER. LABCONCO CORPORATION AND ITS DEALERS ARE NOT RESPONSIBLE FOR SHIPPING DAMAGES.

Do not discard the shipping skid, fan boxes, harnesses, or packing material for your filtered fume hood until you have checked all of the components and installed and tested the unit. Do not remove the filtered fume hood from its shipping skid until it is ready to be placed into its final location. Move the unit by placing a flat, low dolly under the shipping skid, or by using a floor jack.



Do not move the hood by tilting it onto a hand truck.

Ne pas déplacer la hotte en le penchant sur un diable.

Removing the Shipping Skid

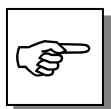

LEAVE THE FUME HOOD ATTACHED TO ITS SHIPPING SKID UNTIL IT IS AS CLOSE TO ITS FINAL LOCATION AS POSSIBLE. MOVE THE HOOD BY USING A SUITABLE FLOOR JACK, OR BY PLACING A FURNITURE DOLLY UNDERNEATH THE SKID. DO NOT MOVE THE HOOD BY TILTING IT ONTO A HAND TRUCK.

After you verify the fume hood components, move your hood to the location where you want to install it. Should you require disassembly to move the hood, then follow the instructions in *Appendix F*. Then, follow the steps listed next to remove the shipping skid from your unit.

1. Remove the side panels by unscrewing the Phillips screws.
2. Find the hardware (bolts, washers, nuts) that attach the fume hood to the skid and remove the hardware. Some hardware is on the sides and some is on the back.

Sash Weight Release

To protect the fume hood from damage in shipment, the sash weight has been secured to the back of the fume hood with screws. Simply remove the screws and make sure the sash cables or chains are on the pulleys or sprockets before operation of the sash.

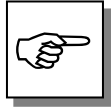

NOTE: THE SASH WEIGHT ITSELF WAS INDIVIDUALLY MATCHED FOR THIS SPECIFIC HOOD AND SHOULD NOT BE EXCHANGED ON ANY OTHER UNIT.

Installing the Hood on a Supporting Structure and Work Surface



The Protector Hood is heavy! Use caution when lifting or moving the unit.

Le Protecteur Hood est lourd! Soyez prudent lorsque vous soulever ou déplacer l'appareil.

When installing the Protector Filtered Hood onto a chemically-resistant work surface or benchtop, ensure that the structure can safely support the combined weight of the fume hood and any related equipment. The work surface should be at least as wide as the hood to properly support it. **The work surface is aligned flush with the back of the filtered fume hood for good airflow: this will provide the correct spacing under the air foil for proper bypass airflow. The lower base cabinets are placed flush with the front of the work surface as shown in Figure 3-1.**



WARNING: It is important to support the rear of the work surface and filtered fume hood. The cross support provides support for the bottom of the work surface. Install the cross support after the base cabinets and work surface are leveled and before installing the hood.

AVERTISSEMENT : Il est important de soutenir l'arrière de la surface de travail et filtré hotte. Le support transversal soutient le bas de la surface de travail. Installer le support transversal après que les meubles et la surface de travail soient nivelés et avant d'installer la hotte.

Chapter 3: Getting Started

The following are instructions for mounting a cross support:

1. Level the base cabinets and the work surface. Work surface should be placed flush with the back of the filtered fume hood as shown in Figure 3-1.
2. Scribe a line on the wall or back of the base cabinet to locate the support under the work surface.
3. Mount the support by attaching it to the wall or base cabinet.
4. Place the hood on top of the work surface and cross support.

The work surface should be smooth and durable, such as a chemically-resistant epoxy resin. The surface should be nonporous and resistant to the acids, solvents, and chemicals used in conjunction with the Protector Filtered Fume Hood. The work surface should also contain a dished recessed area for containing primary spills.

Figure 3-1

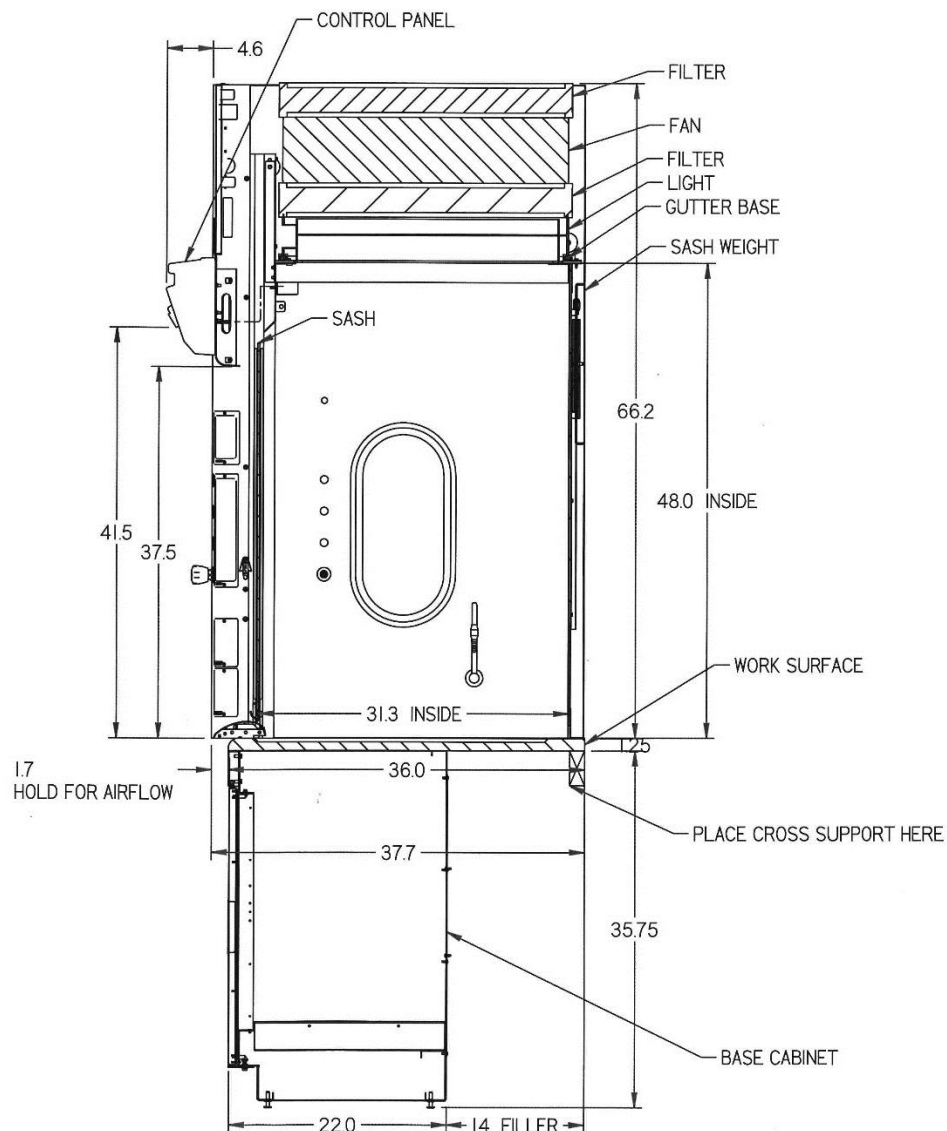

Connecting the Electrical Supply Source to the Protector Hood

Prior to connecting any electrical wiring to the fume hood structure, refer to the hood identification plate for the proper electrical requirements of your specific model.



WARNING: The building electrical supply system for Protector Hoods should include overload protection. A switch or circuit breaker should be in close proximity to the equipment and within easy reach of the operator. The switch or circuit breaker is to be marked as the disconnecting device for the equipment. Consult the current version of NFPA 70®, NEC® for proper installation.

AVERTISSEMENT : Le système d'alimentation électrique de la Hotte Protecteur doit inclure la protection contre la surcharge. Un commutateur ou disjoncteur doit être tout près de l'équipement et à portée facile de l'opérateur. Le commutateur ou le disjoncteur doit être marqué comme l'appareil débranchant pour l'équipement. Consultez la version actuelle de la norme NFPA 70®, NEC® pour une installation correcte.

The identification plate, model number, serial number, and electrical connection boxes are accessible from the front of the fume hood by removing the front panel.

The Protector Hood is normally wired for 115 Volt, 50/60 Hz, 20 Amp or 230Volt, 50/60 Hz, 10 Amp electrical service. Check the I.D. plate behind the front panel for voltage verification. The number of circuits varies depending on the model. All of the electrical connections for the individual duplexes are terminated at the single point internal junction box for hook-up by a qualified electrician. If needed, the individual duplexes can be converted for instant attachment to a wall outlet by a qualified electrician by ordering 115V harness 9582700 or 230V harness 9582701. The main power to the control panel, fans, and lights uses less than 3 amps and a main power cord is included for instant attachment to a wall outlet. The single point internal junction box is used for the connection of the duplex outlets. Refer to the wiring diagram for your Protector Hood in *Appendix C: Protector Filtered Hood Specifications*.

The fume hood is required to be grounded to the MAINS protective earthing ground for safe operation. Using a ring terminal sized for a 10-24 machine screw, connect the MAINS ground conductor to the grounding lug marked with the protective earthing symbol, . Only MAINS ground conductors should be connected to the protective earthing ground lug, no other conductors should be connected to this grounding lug. Using wire nuts, connect the MAINS supply conductors to the fume hood supply wires. Ensure that the wires are connected as per the appropriate wire color codes for the input voltage. For 115V Phase (Hot) is black and Neutral is

Chapter 3: Getting Started

white, for 230V Phase1 is brown and Phase2 is blue. Refer to the wiring diagram for your Protector Hood in *Appendix C: Protector Filtered Hood Specifications*.

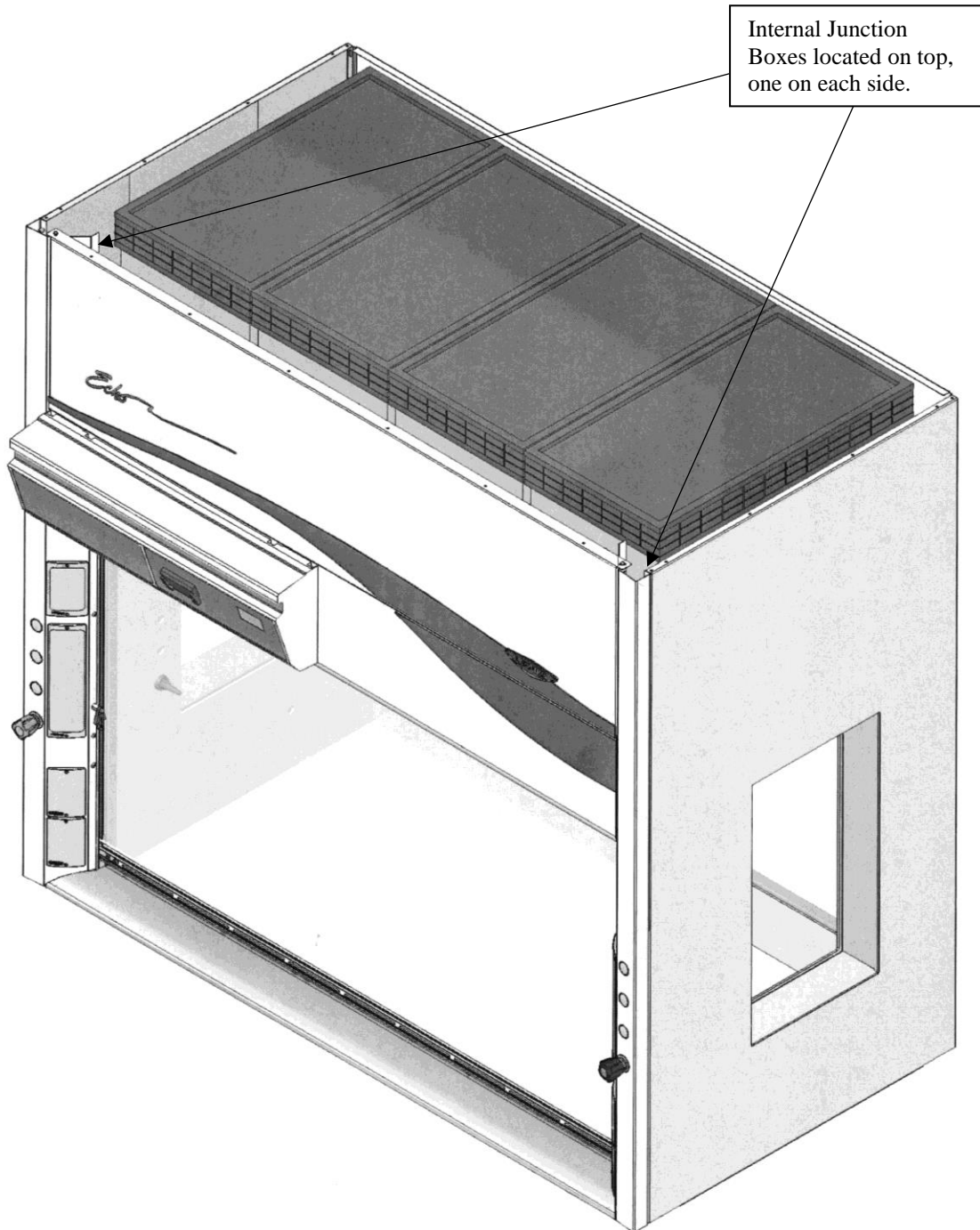
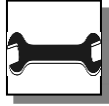

Figure 3-2



All wiring for the filtered fume hood SHOULD be performed by a licensed electrician and conform to all local codes.

Tout le câblage pour la hotte filtrée doit être effectuée par un électricien agréé et conformément à tous les codes locaux.

The fluorescent light has been mounted inside the light module located on top of the filtered hood. To change the fluorescent light bulbs in your filtered hood, you must first remove the front panel from the hood. Next remove the filters, pre-filters, and fan modules. Lift fixture up and replace any defective bulbs. Reverse order to reassemble.

Connecting the Service Lines to the Protector Hood

The filtered hoods with service fixtures have been plumbed from the valve to the hose connector or gooseneck for your installation convenience. Supply tubing shall be provided by the qualified installer. Tubing can enter the filtered hood from above, through the back, or through the work surface to make these connections to the service fixtures.



NOTE: Inspect all fittings for leakage. Tighten the fittings slightly if needed.

NOTE : Inspecter toutes les installations à la recherche de fuite. Resserrer les installations légèrement si nécessaires.



CAUTION: Do not use oxygen with any standard service fixture. Contact Labconco Customer Service for oxygen fixture information.

PRUDENCE : Ne pas utiliser de l'oxygène avec l'accessoire de service standard. Contacter le Service Clientèle de Labconco pour les informations d'accessoire d'oxygène.

Should access to the filtered hood plumbing fixture bodies be required, remove the service access plate on the hood front corner posts by loosening their individual screws (see item 11, Figure A-1 in *Appendix A*). The valve body will now be fully exposed for any service work that may be necessary. The service fixtures supplied on your laboratory hood are designed for use with the following services:

- Air
- Hot Water
- Vacuum
- Cold Water
- Natural Gas – See caution below



WARNING: Contact Labconco Customer Service directly before using any service other than those listed above in these valves to assure full compatibility.

AVERTISSEMENT : Contacter le Service Clientèle de Labconco directement avant d'utiliser n'importe quel service autre que ceux énumérés au-dessus dans ces soupapes pour assurer une pleine compatibilité.



CAUTION: Natural gas should be used only in the service fixture that has been pre-plumbed with brass tubing. Sulfur content of the gas could cause deterioration of standard copper supply lines.

PRUDENCE : Le gaz naturel devrait être seulement utilisé dans l'accessoire de service qui a été pré soudé avec des tuyaux de cuivre. Le contenu soufré du gaz pourrait causer la détérioration des lignes d'alimentation en cuivre standard.

Sealing the Protector Hood to the Work Surface

When the filtered hood has been set in place, ducted, wired, and plumbed, it should be sealed at the work surface to prevent spilled materials from collecting under the walls of the hood. Materials such as silicone sealants are recommended to seal the hood structure.

Setting Up the Protector Echo Floor-Mounted Filtered Hood

Specific instructions are detailed in Appendix J to assemble and maneuver the Protector Echo Floor-Mount into your laboratory.

Commissioning the Filtration Technology

Overview

1. Confirm order and check supplies.
2. Locate cardboard box from the pallet, the controller on the front header, the temperature sensor inside the filtered hood and the sash sensor on the left side.
3. Install Card Holder and locate Admin Card, User Card and Maintenance Card.
4. Unpack all the filters.
5. Unpack lights, put up gutters and light box with pre-filters.
6. Check for pre-filter and install primary filter on light box.
7. Unpack fans and stack on top of primary filters.
8. Place the secondary filter on a fan box.
9. Repeat steps 3-7 until all the technology is stacked.
10. Check the Micro switch settings on the fans.
11. Install the light wires.
12. Install the fan wires.
13. Install the air sampling tubing.
14. Install the electrical cord (already completed for convenience).
15. Snake all connections up through the super structure. Make all connections from control panel to technology.
16. Plug in power cord and reconfigure.

Step 1 – Confirm order and check supplies.

1. Confirm the order. Make sure you have the correct number of fans for the hood size either:
 - M1 (1 column filtration) 3ft Protector Airo
 - M2 (2 column filtration) 4ft Protector Echo/Airo
 - M3 (3 column filtration) 5ft Protector Echo
 - M4 (4 column filtration) 6ft Protector Echo
 - M5 (5 column filtration) 8ft Protector Echo
2. Make sure that you have located the power supply cord to attach power to the wall. If needed, the inlet power may be hard wired at the internal junction box.
3. Have the following tools and supplies:
 - 6ft ladder
 - Double sided tape for temp sensor
 - #2 Phillips for controller screws from controller to bracket
 - Zip ties to keep wires from moving parts of the superstructure
 - 12 volt cordless drill to mount controller bracket to superstructure (already completed)
4. The fan box with a number based on its position and micro switch settings is labeled whenever possible except for large installations. Each fan will

Chapter 3: Getting Started

have a number 1, 2, 3, 4 or 5 as to the location of the fan module. From left to right facing the superstructure, fan 1 will be to the left, then 2, 3, 4, and 5 to the right depending on the size.

5. Each Protector Hood will have the following Neutrodine filters based on their size per each hood installed.
 - M1 (1 column filtration) 2 total Neutrodine filters
 - M2 (2 column filtration) 4 total Neutrodine filters
 - M3 (3 column filtration) 6 total Neutrodine filters
 - M4 (4 column filtration) 8 total Neutrodine filters
 - M5 (5 column filtration) 10 total Neutrodine filters

Step 2 – Locate cardboard box on the pallet, the controller on the front header, the temperature sensor inside the hood, and the sash sensor on the left side.

For your convenience, the cardboard box on the pallet contains the operational cards to run the hood along with the modular fan and light harnesses and air sampling tubing. Please locate these now. Then locate the pre-mounted controller on the front header, the temperature sensor inside the hood, and the sash sensor on the left side of the hood. These components have been pre-mounted for convenience. Note: See Figure 3-3 on page 21 that depicts the sash sensor for all models and the rotated Filtration Technology applicable to only the 3' x 31.7" Airo, model numbers 1843000-xx.

Step 3 – Install Card Holder and locate Admin, User and Maintenance Cards.

Card holder snaps into control panel. See Figure 3-3. Cards and card holder are located in important contents cardboard box.

Step 4 – Unpack all the filters.

Unpack all of the Neutrodine filters for the hood you are commissioning. The Neutrodine filters are shipped separately from the filter manufacturer to your job site. Remove all packing material, lay them flat and stack them out of the way of the front of the superstructure but near it.

Step 5 – Unpack lights, put up gutters, light box and pre-filters.

On the top of the opened box you will find a rectangle “gutter.” Place that on top of the superstructure first.

With gutter on, next put up the light out of that same box. Make sure that the edge of the light box is properly seated into the foam of the gutter on all sides.

Now make sure the light has a white pre-filter inside the light box itself.

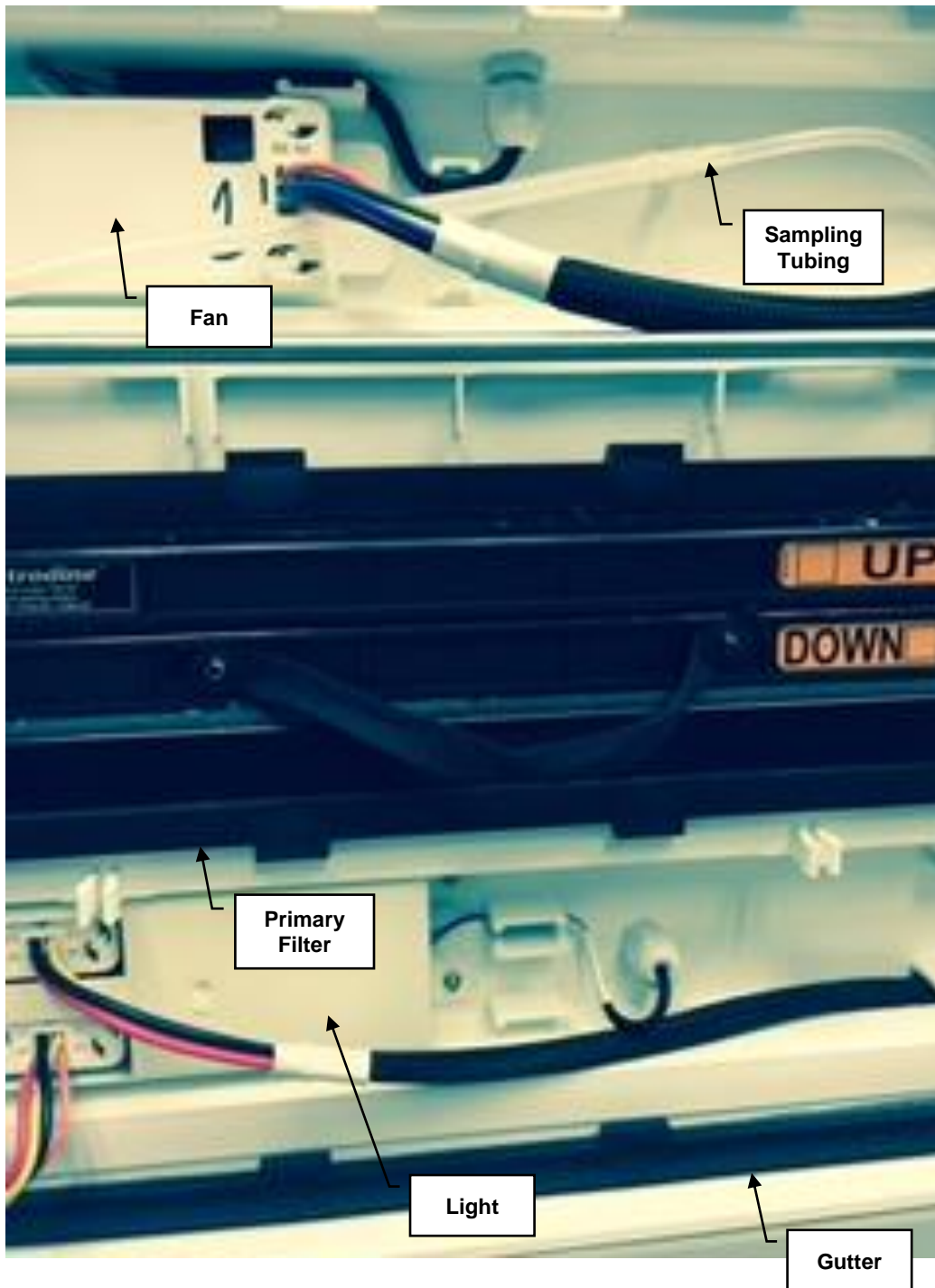

Step 6 – Check pre-filter and place primary filter on light box.

With the pre-filter in place now you are ready to put up your first Neutrodine filter. Put the first filter on top of the light box putting the RFID tag end of the filter facing out towards the front of the superstructure. Follow the stickers for up and down positions that are on the filters.

Make sure the filter is properly seated on all sides of the light box.

Chapter 3: Getting Started

Step 7 – Unpack fans and stack on top of primary filters.

Now place the fan that you removed from the packaging and place on top of the Neutrodine filter. Make sure the fan motor is up as shown below.



NOTE: M4 Wiring Shown

Step 8 – Place the secondary filter on fan box.

Put the secondary filter on top of the fan box putting the RFID tag end of the filters facing out towards the front of the superstructure. Follow the stickers for up and down positions that are on the filters.

Make sure the filter is properly seated on all sides of the fan box.

Step 9 – Repeat steps 3-7 until all the technology is stacked.

Now repeat steps 3-7 until you have all the technology stacked on the superstructure. Make sure all filters are properly seated on all sides.

Step 10 – Check the micro switch settings.

Check the “Dip” switches on the front of each fan. Make adjustments as needed.

Based on their positions from left to right:

Fan #1 should be **On, Off, Off, Off = Down, Up, Up, Up**

Fan #2 should be **On, Off, Off, On = Down, Up, Up, Down**

Fan #3 should be **On, Off, On, Off = Down, Up, Down, Up**

Fan #4 should be **On, Off, On, On = Down, Up, Down, Down**

Fan #5 should be **On, On, Off, Off = Down, Down, Up, Up**

If you need to adjust the DIP switch you may use a very small regular screw driver or even a pencil. Make your adjustments by putting light pressure on the DIP switch to either move it up (**off**) or down (**on**).

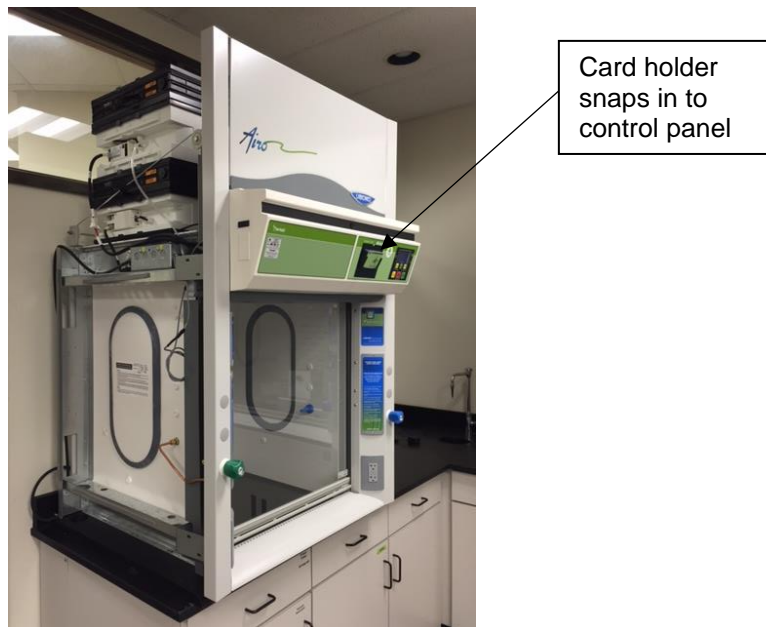
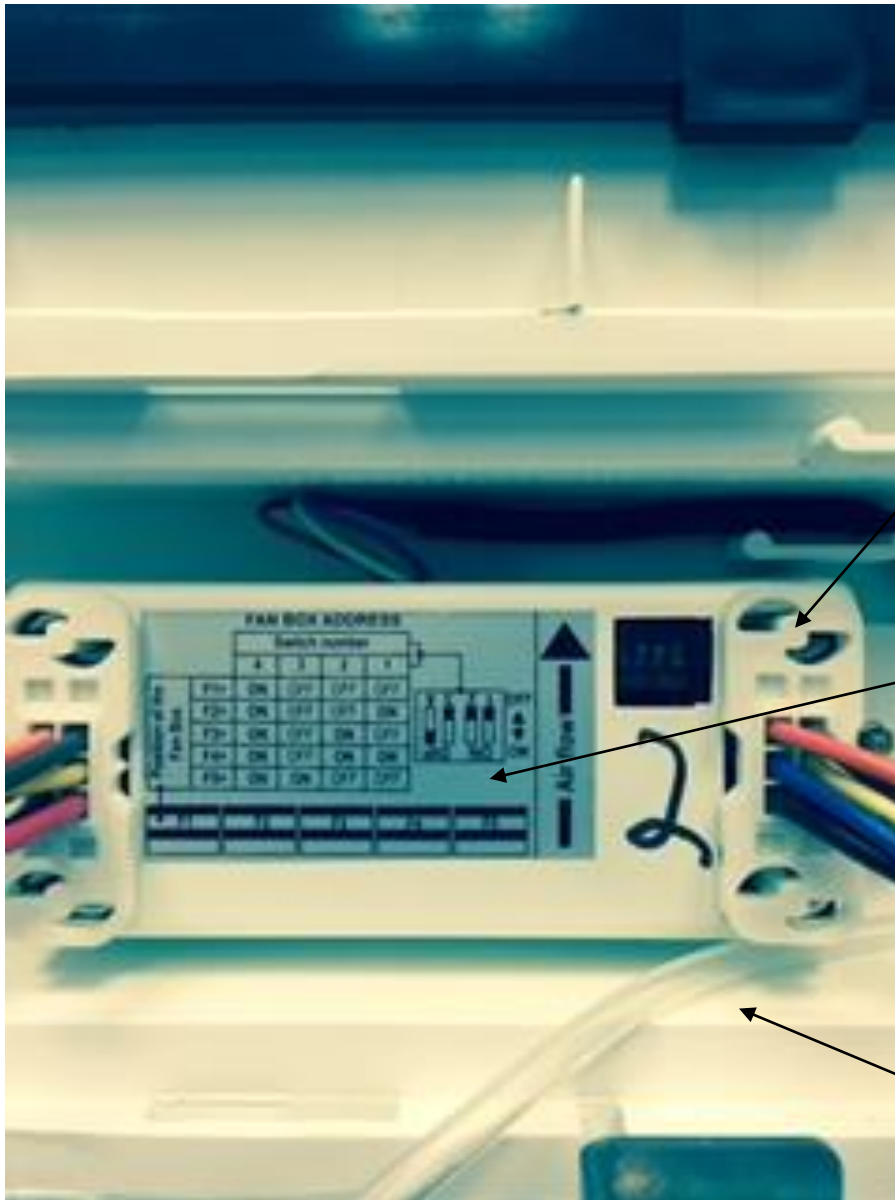

Figure 3-3
Sash Sensor and 3' x 31.7" Airo with Filtration Technology Rotated

Chapter 3: Getting Started



Dip Switches

Dip Switch Legend per fan position

Sampling Tubing

Step 11 – Install the light wires.

Now install the light wires connecting all the lights together. The sequence is top left to bottom right. Then top left to bottom right until all the lights are connected. The notched groove on the connector is always to the top.

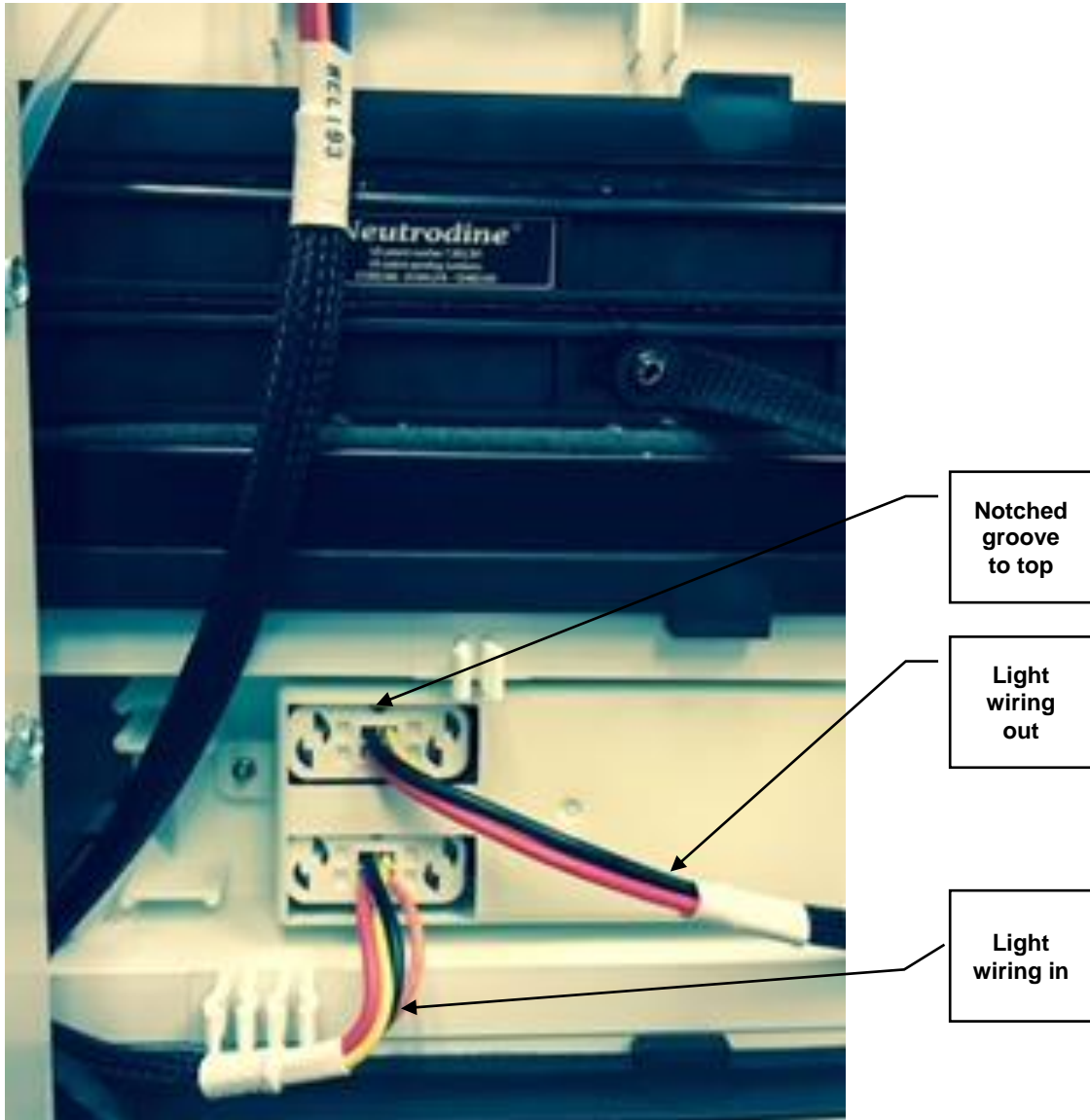

Chapter 3: Getting Started

Step 12 – Install fan wires.

Connect the fans with fan wires. Start with the fan farthest to the left. Put the wire into the right slot on the fan circuit board to the left side of the fan box to the right. The v-notched groove on the connector is always to the right.

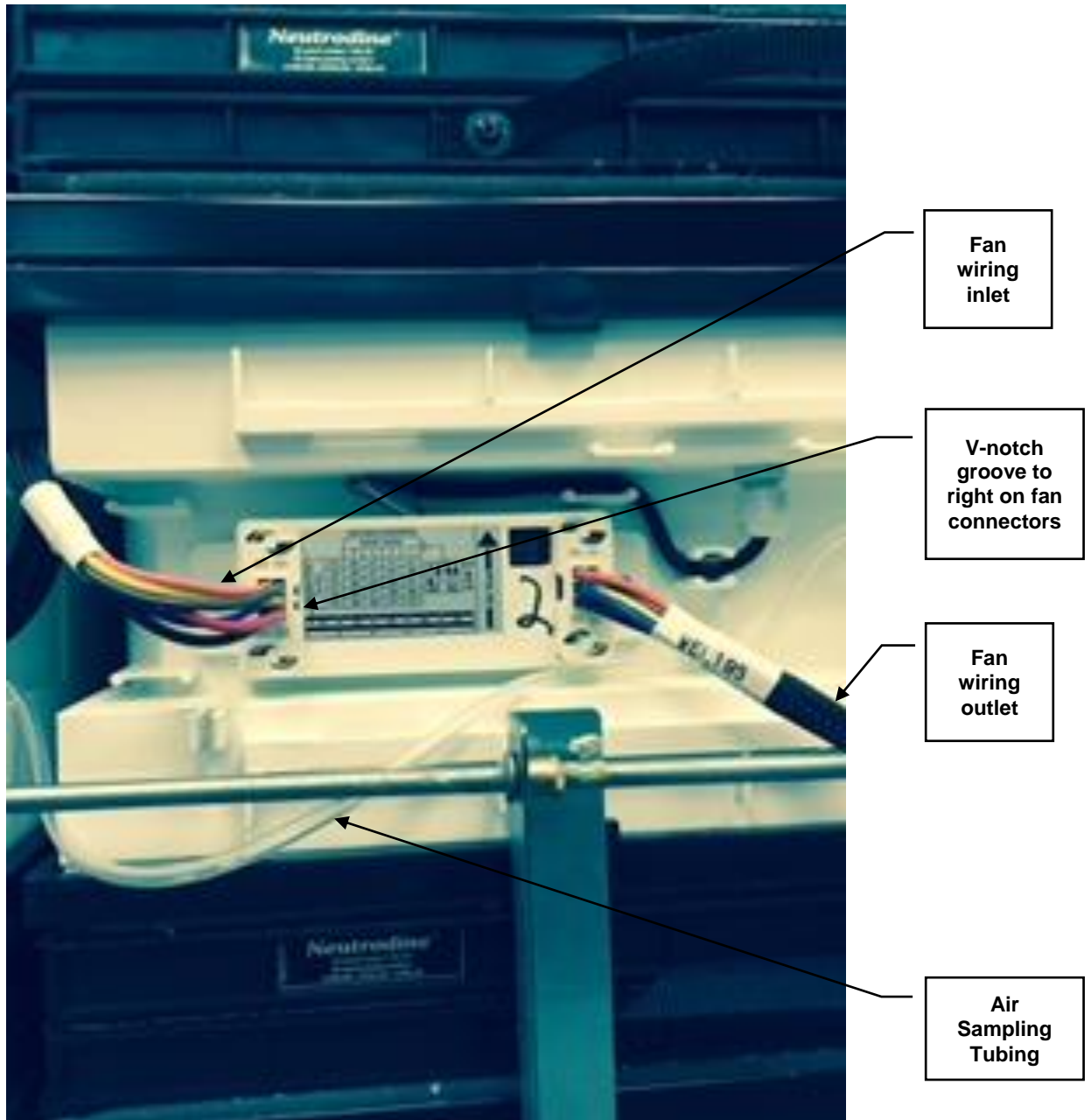

Step 13 – Install air sampling tubing.

Slide the air sampling tubing onto fan #1. Put the small “t” onto the fan box and run the other end over to the right to fan box #2.

Make sure the tubing is securely connected to each fan box. Repeat the step until all fan boxes are connected together by the tubing.

Step 14 – Install electrical wiring to controller.

NOTE: This step was completed at the factory for your convenience but is shown for maintenance purposes. Be sure the 13' IEC Power Cord is connected to the Controller and ON/OFF switch is ON. Please wait until Step 15 to connect power to a wall outlet.

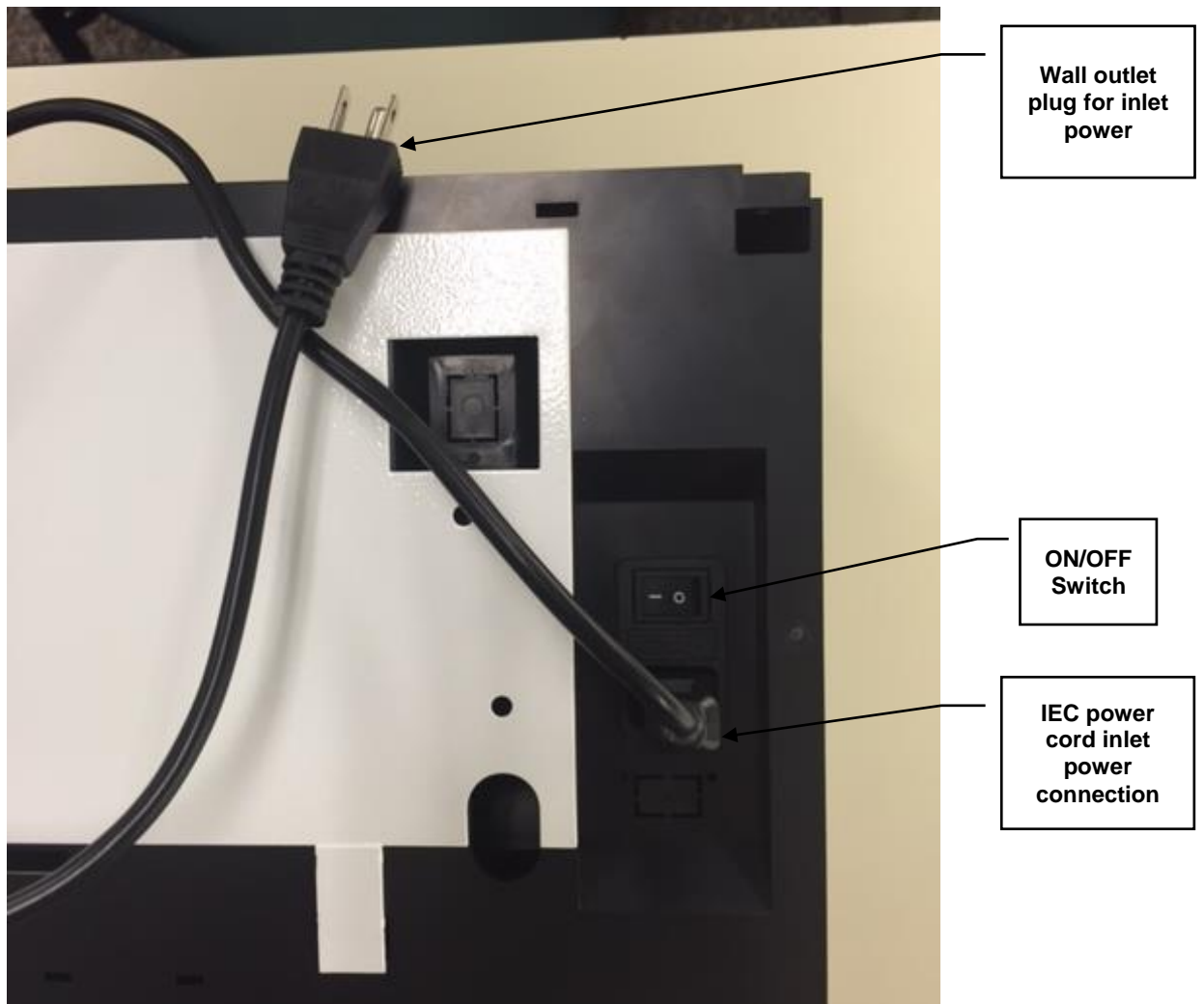

Chapter 3: Getting Started

Step 15 – Make all connections from control panel to technology.

In order to connect the control module to the fans and lights, you must first locate the following connections from the control module to the technology:

- Light supply wire from control module to light #1
- Fan supply wire from control module to fan #1
- Air tube from control module to the “T” on fan #1 (If necessary, use extension tubing and plastic fitting from cardboard box on pallet)
- Temp sensor (already connected)
- Sash sensor (already connected)

NOTE: Please reference pictures from Steps 4, 6, 9 and 11.

You should now have those connections located next to the technology.

Now connect all those connections to the technology.

Step 16 – Plug the power cord in and reconfigure.

Now plug in the controller. You will see it say “Booting” as it comes on. If it indicates hardware mismatch alarm 9a, follow the “Reconfigure process” combined with the GFH settings sheet to finish the installation. (Instructions for Reconfigure process start on page 29.)

Have a maintenance card in the card reader and follow the “reconfigure process” at Step #4 Delete Factory configuration (see page 31). Locate the GFH settings sheet that is in each command module for the settings to enter when it is called for during the “reconfiguration process.”

If after a Reconfigure there is still a problem, check all of your connections to be sure they are properly seated. Then unplug the controller to reboot it. If it still gives an error after this please see the Initial Troubleshooting Tips on pages 43-45. If that does not solve the issue, please contact Labconco/Erlab Product Service.

Re-Configuration Process

Events in which you have to “Re-configure”

- Installing or commissioning a GFH for the first time
- Replacing a fan board or a complete fan box
- Replacing an Electro/Acid Sensor
- Replacing a solvent sensor
- Replacing a RFID board
- Replacing a CPU board
- Replacing a complete control module
- Sash sensor failure
- Hardware Configuration mismatch 9A alarm

Before beginning, you will need to have the following:

- Green Fume Hood Settings sheet (example provided on next page)
- 6ft Ladder
- Any tools needed for removal of front panel
- Some white out, or a small sticker to mark the round RFID tags that are on the primary filters only (the primary filters are the lower ones that are in between the lights & fan box)
- Piece of paper and a pen
- Maintenance card
- The User card that is used to operate the hood you are going to re-configure

Example of Protector Filtered Fume Hood Settings Sheet**Labconco**

Fan set points are based on ASHRAE 110 testing results conducted at Labconco.

Fan Set point **Dflt 2850 rpm**

Fan Set point **Min 1500 rpm Variable Volume, 2850 rpm Constant Volume**

Semicon/Solvent sensor

Trig. 3500mv based on your LP questionnaire data LP #GFH-XXXXXXXXXX

Delay: **15 min**

Electro/Acid sensor

Trig. Factory set based on sensor ppm value of the gel sensor itself

Delay: **15 min**

Sash **Inverted Polarity**

Trig. **65%**

Days on filter: Set it to the max of **730** days. This is always set to the maximum of two years on every installation.

Activated audible alarms

All alarms are active (audible) out of the box.

K, Solvent alarm threshold permanently exceeded. Saturated filters modules

N, Acid alarm, threshold permanently exceeded. Saturated filter modules

Q, End of acid sensor lifetime alarm

V, 40°C temperature alarm exceeded in the enclosure

W, Top priority alarm 60°C temperature alarm threshold exceeded in the enclosure

This data is needed for initial commissioning and if a reconfiguration is needed on the hood during any service work.

Overview

1. Identify why it is in mismatch.
2. Write down parameters under “Hood status” menu.
3. Remove front panel.
4. Delete current configuration.
5. Create new configuration.
6. Scan in filters.
7. Set Semicon Trig. Value.
8. Scan in User cards.
9. Enter network parameters (if applicable).
10. Set fan speeds.
11. Set alarm delays & choose sash type.
12. Authorize administrator for alarms.
13. Set audible alarms.
14. Calibrate the sash.
15. Turn on hood and check operation.

Step 1 – Identify why it is in mismatch.

You must first identify why it is in mismatch. To do this:

Insert the maintenance card in the cardholder on the GFH and in the window you will see:

**Hardware configuration mismatch 9A
(Maintenance)**

- **Hardware Mismatch
Hood Status
Administration menu
Maintenance menu**

At the “**Hardware Mismatch**” press “**Ok**” to open the menu.

Then arrow down to see which component it says has failed or is unidentifiable. If it is a fan, for example, you may reconfigure but if it is any other component you must contact Labconco Product Service.

Chapter 3: Getting Started

So that the event can be logged, provide Labconco Product Service with the serial # of the control module along with the component that failed.

Note at any time if the LCD screen loses illumination press “Ok” and it will light back up.

If the “**Hardware Mismatch**” menu is not seen you may find it by opening the “**Hood Status menu.**”

Arrow down to “**Hood Status**” and press “Ok” to open it.

Step 2 – Write down parameters under “Hood Status.”

If you are commissioning a new hood with all brand new filters, proceed to step 3.

If doing a filter change, go to “Hood Status” and arrow down to Filter __ D. Write down this number for use in step 6.

You only need to proceed to the rest of Step 2 if the gGuard software package is installed. If it is not, proceed to step 3.

In case it is still not shown, press “Ok” to open the “**Hood Status**” menu again.

Then arrow up or down to record the following on paper:

DHCP: X

IP: XXX.XXX.XXX.XXX

MSK: XXX.XXX.XXX.XXX

GW: XXX.XXX.XXX.XXX

If DHCP is **yes** then you have a dynamic IP if **no** then you have a static IP which you must reenter completely.

Elapsed Time

Filter X D (this is the # of days since install)

Fans

Set point Dflt. XXXX rpm

Set point XXXX rpm

Semicon S. trig value (example 3500)

Trig. X

Delay X

Sash

Which type (example. inverted polarity)

Trig X %

Now press “X” to return to the previous menu.”

Step 3 – Remove front panel.

Use your ladder and remove the upper front panel so you can access the RFID filter tags later in this procedure.

Step 4 – Delete current configuration.

You should now see on the screen:

>Hood Status
Administration menu
Maintenance menu

Arrow down to “Maintenance Menu” then press “Ok” to select it.

You should now see:

>Hood Integration
Semicon S. Alarm Delay
Electro S. Alarm Delay
Sash Sensor Trig.
Software Releases
Audible Alarm Mgmt.

At “Hood Integration” press “Ok.”

Then arrow down to “Delete Factory Cfg” and press “Ok.”

You should now see “000000000.” Press “Ok” until the cursor is on the fourth zero from the right.

“000000000”

Now arrow up once to make a “1” press “Ok.”

Arrow up twice to make a “2” press “Ok.”

Arrow up three times to make a “3” press “Ok.”

Arrow up four times to make a “4.”

You will now have “0000001234.”

Note if you make a mistake you can press “X” to move back to the left and change the entry.

If it is correct then press “Ok.”

You should now see “Hood will reboot please be patient.”

Chapter 3: Getting Started

Step 5 – Create new configuration.

After it reboots you will now see:

>Language
Date and Time
Maintenance Menu

Select “**Language**” by pressing “**Ok.**”
Arrow down to “**English**” then press “**Ok.**”
Now press “**X**” to return to the previous menu.

Arrow down to “**Date and Time**” press “**Ok.**”

You should see:

>Date
Time
Format

Arrow down to “**Format**” then press “**Ok**” to set it to “**MMDDYY.**”

If the date and time are correct you may “**Save and Exit**”

If date and/or time are incorrect, arrow up and down to each menu press “**Ok**” to select it and correct it.

Then “**Save and Exit**” after your changes.

You should now see:

>Language
Date and Time
Maintenance Menu

Arrow down to “**Maintenance**” and select it by pressing “**Ok.**”
You will see “**Hood Integration**” press “**Ok.**”

“**Create factory CFG**” press “**Ok.**” Wait a few seconds and you will see the following:

“**Discovered Hardware**”
Fan(s) the # of fans that your hood has, either an M1, M2, M3, M4, or M5
Electro (S): “**Yes**”
Semicon (S): “**Yes**”
Sash Sensor: “**Yes**”
Temperature Sensor: “**Yes**”

If any of these parameters says “No” then press **“X”** to go back and create it again. If on the second attempt you do not see all components then recheck all component connections or you must contact Labconco Product Service.

If all parameters say “Yes” then press **“Ok.”** The hood will now reboot.

Step 6 – Scan in Filters.

After rebooting, it will show:

Access granted
(Maintenance)
No Filters installed
>Hood Status
Administration menu
Maintenance menu

Arrow down to the **“Administration menu”** and press **“Ok”** to select it.

You should see:

Language
Date and Time
Filters
Alarms and Sensors
Users and Management
Network Parameters
Erase History
Ventilation

Arrow to **“Filters”** and press **“Ok”** to select it.

You should now see:

>Filter list
Total replacement
Partial Replacement

Arrow down to **“Total Replacement”** press **“Ok.”**

Press **“Ok”** three times until you see **“Record new filter tags” 0/12.**

Note it is important that the tags are not mixed up. The primary RFID tags remain on the primary filters and the secondary tags remain on the secondary filters.

Now take off the RFID tags that are on your primary filters only.

Remove your Maintenance card.

Scan in your black RFID tags from your primary filters.

Chapter 3: Getting Started

Place those RFID tags back on the primary filters.

Take off the RFID tags that are on your secondary filters only.

Scan in your black RFID tags from your secondary filters.

Place those RFID tags back on the secondary filters.

The “0” should now be the number of filters that you have. If not, then rescan them. If it is not in the database, it will scan it in. If it is in the database, it will say **“Already in database.”**

When you have the correct number of filters press **“Ok”** three times.

Reinsert your maintenance card press **“Ok.”**

You should now see **“Enter Filter Lifetime”**

365D
5M
730MAX

When commissioning a new hood or changing an Electro sensor, always use the **Max of 730 days**. If you are changing out old filters, take the Filter __ D you wrote down from Step 2 and subtract it from 730 to find the new primary filter lifetime.

For example,

The display from Step 2 says “Filter 85 D”

$$\begin{array}{r} 730 \\ - 85 \\ \hline = 645 \end{array}$$

In the above example, the number you would enter would be 645 for the days.

Arrow down or up to get your number and then press **“Ok.”**

You will now see:

Filter list
Total replacement
Partial replacement

Press **“X”** to return to the previous menu.

You should see:

Language
Date and Time
Filters
Alarms and Sensors
Users and Management

Network Parameters
Erase History
Ventilation

Arrow to **“Alarms and Sensors”** and press **“Ok”** to select it.

Step 7 – Set semicon trigger value.

You should see:

>Maintenance Alarm
Deactivation Rights
Semicon S. Trig. Value
Sash Sensor Calib.

Select **“Maintenance Alarm”** by pressing **“Ok”** to select it.

You will now see:

Maintenance Alarm Activated “Yes”

Press **“Ok”** so it says **“No.”**

Arrow down to **“Save and Exit.”**

Press **“Ok”**

Arrow down to **“Deactivation Rights”** press **“Ok”** to select it.

You will now see:

“Deactivation” “No.”

Press **“Ok”** so it says **“Yes.”**

Arrow down to **“Save and Exit.”**

Press **“Ok.”**

Arrow down to **“Semicon S. Trig. Value”** press **“Ok”** to select it.

You will now see:

>Value
CAS number
Molecule list

Press **“Ok”** to select **“Value.”**

Now arrow up and down and put in **“X” for trig.** Value from your notes in step two or refer to your GFH settings sheet. If unknown, use 3500 MV.

“Confirm new value” and press **“Ok”** to confirm.

Press **“X”** to return to the previous menu.

Disregard the sash calibration for now. It will be covered later.

Chapter 3: Getting Started

Press **“X”** again to return to the previous menu.

Step 8 – Scan user cards.

Now you should see:

Language
Date and Time
Filters
Alarms and Sensors
Users and Management
Network Parameters
Erase History
Ventilation

Arrow down to **“Users and Management”** press **“Ok”** to select it.

You should see:

>Set
List
Delete

Select **“Set”** by pressing **“Ok”** to select it.

Scan in the **“user card”** that was used at that hood.

Do this by removing the **“Maintenance card”** to scan in the **“user card.”**

You should hear a beep and the screen will say **“user added.”** Now press **“Ok.”**
Then **“X”** to return to the previous menu. Remove user card and reinsert
Maintenance card.

Step 9 – Enter network parameters.

Skip this step if you do not have gGuard.

You should now see:

Language
Date and Time
Filters
Alarms and Sensors
Users and Management
Network Parameters
Erase History
Ventilation

Arrow down to **“Network parameters”** and press **“Ok”** to select it.

You will now see: **>Ethernet**
Bluetooth

Press **“Ok”** to select **Ethernet.**

DHCP press “**Ok**” to say “**No**” for static IP assignment if dynamic IP used.
DHCP should be “**yes.**”

Refer to your notes from step 2 or use your lab diagram as a reference.

For Static IP enter what you recorded in step 2.

IP:
MSK:
GW:

When you enter the last number of the “**GW:**” check that you entered the correct numbers, if it is not correct then you must correct it before proceeding.

If correct, arrow down to “**Save and Exit**” and press “**Ok.**”

You will now see **Ethernet**
Bluetooth

Press “**X**” to return to the previous menu:

Language
Date and Time
Filters
Alarms and Sensors
Users and Management
Network Parameters
Erase History
Ventilation

Do not touch the last two items in the menu.

Press “**X**” again to return to the previous menu.

Step 10 – Set fan speeds (NOTE: Fans must be off. Turn off now!)

You should now see:

>Hood Status
Administration menu
Maintenance menu

Arrow down to “**Maintenance menu**” press “**Ok**” to select it.

You should now see:

>Hood integration
Fan set point
Semicon S. Alarm Delay
Electro S. Alarm Delay
Sash sensor trigger
Software releases

Chapter 3: Getting Started

Audible alarm Mgmt.

Arrow down to **“Fan set point”** press **“Ok”** to select it.

You should now see:

>Default (2850)

Minimal (1500)

Reference your GFH Settings Sheet, arrow down to **“Default”** press **“OK”** to select it. Enter value from GFH Settings Sheet.

“Confirm new value” press **“Ok”** to confirm.

Arrow down to **“Minimal”** press **“Ok”** to select it.

Enter value from GFH Settings Sheet.

“Confirm new value” press **“Ok”** to confirm.

Press **“X”** to return to the previous menu.

Step 11 – Set alarm delays and choose the sash type.

Reference your GFH Settings sheet for the following step:

You should see:

>Hood integration

Fan set point

Semicon S. Alarm Delay

Electro S. Alarm Delay

Sash sensor trigger

Software releases

Audible alarm Mgmt.

Arrow down to **“Semicon S. alarm Delay”** press **“Ok”** to select it.

You will see:

05 Minutes

1 Min

60 Max

Make the **0** a **1** for **15 Minutes**

Press **“Ok”** then **“Confirm new value”** press **“Ok”** to confirm.

You should see this menu again:

>Hood integration

Fan set point

Semicon S. Alarm Delay

Electro S. Alarm Delay

Sash sensor trigger

Software releases

Audible alarm Mgmt.

Arrow down to **“Electro S. alarm Delay”** press **“Ok”** to select it.

You will see:

05 Minutes

1 Min

60 Max

Make the **0** a **1** for **15 Minutes**

Press **“Ok”** then **“Confirm new value”** press **“Ok”** to confirm.

You should see this menu again:

>Hood integration

Fan set point

Semicon S. Alarm Delay

Electro S. Alarm Delay

Sash sensor trigger

Software releases

Audible alarm Mgmt.

Arrow down to **“Sash sensor trig.”** Press **“Ok”** to select it.

Refer back to your notes from step 2 for the type of **Sash sensor** and **trig. X%** value

Arrow down to **“SRS Inverted Polarity”** then press **“Ok”** to select it.

“Confirm new value” press **“Ok.”**

You will see **Sash sensor trigger.**

Enter the **65%** as the trig value, press **“Ok.”**

“Confirm new value” press **“Ok.”**

Press **“X”** to return to the previous menu.

Step 12 – Authorize Administrator for alarms.

You should see:

>Hood integration

Fan set point

Semicon S. Alarm Delay

Electro S. Alarm Delay

Sash sensor trigger

Software releases

Audible alarm Mgmt.

Arrow down to **“Audible alarm Mgmt.”** Press **“Ok”** to select it.

You should see **“Admin Authorized No.”** Press **“Ok”** to have it say **“Yes.”**

Arrow down to **save and exit** press **“Ok.”**

Chapter 3: Getting Started

Step 13 – Set audible alarms.

You should now see:

Hood Status
Administration menu
Maintenance menu

Arrow up to **“Administration menu”** and press **“Ok”** to select it.

You should now see:

Language
Date and Time
Alarms and Sensors
Users and Management
Network Parameters
Erase History
Ventilation

Arrow down to **“Alarms and Sensors.”** Press **“Ok”** to select it.

You should see:

>Maintenance Alarm
Deactivation Rights
Semicon S. Trig. Value
Sash Sensor Calib
Audible alarm activation

Arrow down to **“Audible alarm activation.”** Press **“Ok”** to select it.

Turn on alarms that are stated on the GFH settings sheet. For example **8K, 8N, 8Q, 8V,** and **8W.**

Arrow down to **“8K.”** Press **“Ok”** to select it.

You should see **“Repl. Main filters: Off.”** Press **“Ok”** to make it a **“Yes.”**
Then arrow down to **“save and exit.”** Press **“Ok”** to save and exit.

Repeat for all the remaining alarms.

After the last alarm is set, press **“X”** to return to the previous menu.

Step 14 – Calibrate the sash.

You should see:

Maintenance Alarm
Deactivation Rights
Semicon S. Trig. Value
Sash Sensor Calib
Audible alarm activation

Arrow up to **“Sash sensor calib.”** Press **“Ok”** to select it.

Follow the instructions:

“Fully close the sash.” Press **“Ok.”**

“Fully open the sash.” Press **“Ok.”**

“Confirm new value.” Press **“Ok”** to confirm.

*****Now lower the sash to a safe operating height.*****

Press **“X”** to return to the previous menu.

Press **“X”** again to return to the previous menu.

You should see:

Hood Status

Administration menu

Maintenance menu

Step 15 – Turn on hood & check operation.

Turn on the **“lights”** and **“fans.”**

Arrow up to the **“Hood status menu.”** Press **“Ok”** to double check your data.

Examples follow of numbers you may see from notes taken in Step 2.

Example of static IP (needed for gGuard)

Ethernet network

DHCP: No

IP: 192.168.0.20

MSK: 255.255.255.0

GW: 192.168.0.1

Elapsed times

Filter XD *****Note**** It will be 0 as the clock starts over at the time of Reconfiguration (the memory is wiped clean). It displays the current days on the filters, so for example tomorrow will show 1 then the next day a 2. However, the CPU is still counting down the days from the number that you entered from step 5.

Example of fan speeds

Fans

Dflt 2850 rpm

Set point 1500 rpm Variable Volume, 2850 rpm Constant Volume

These values should be the ones that you entered earlier from your notes in step 2.

You should then see an rpm value (make sure hood is on and press **“Ok”** to refresh) for all the fans that your hood has based on the hood size (either a M2, M3, M4 or M5).

Chapter 3: Getting Started

Example, M4 will have four fans. Your numbers will be different based on your parameters.

Fan 1; 1533

Fan 2: 1522

Fan 3: 1511

Fan 4: 1630

Fan 5: -----

Example

Semicon Sensor

Trig. M 3500 MV

Delay 15mn

Electro Sensor

Delay 15 mn

Sash

Type Inverted polarity

Trig. 65%

Now check the audible alarm for the sash by raising the sash so it sounds. The height you hear it should be the upper end of the safe working height above the sash stop.

If not, make sure you calibrated it. If needed, recalibrate it until it is correct. To do this turn the hood off and reselect the sash type and then recalibrate it.

They should all match your notes from step 2 and your GFH settings sheet except that the days will start over at 0 and count to 730 or the number that was entered.

If everything was entered correctly, the filtered hood will function properly. Otherwise you must turn it off and reenter the correct parameters. If you still have a problem please contact Labconco Product Service.

Troubleshooting Guide for GFH

Here is your Troubleshooting Guide for your GFH, as these scenarios are most common.

During installation of the fume hood:

- 1) **“The hood is in mis-match alarm (9A), why?”**
 - a. This is correct. You must perform the re-configuration process after all the filtration technology is installed and connected. See pages 28-29 of the User’s Manual for the steps to re-configure. Please be patient and follow each step.

- 2) **“The re-configuration is missing some components, what do I do now?”**
 - a. Ask the customer/installer which specific components are missing: the screen on the GFH Command Module (the Erlab box with the display screen) will display “No” after them (e.g. fans, temp sensor, sash sensor, semicon. sensor or electro sensor).
 - b. For that missing component, double check that it is physically and properly plugged in. There is a short cord coming from the Command Module for each component that will plug either directly into the component (fan, light) or into a cord coming from the component (sash sensor, temp sensor).
 - c. If the missing component is plugged in and still not being seen, ask that they unplug and then plug it back in again. Press the “X” button on the display and then the “OK” button to “Create Factory CFG” (this is step 5 of the Reconfiguration process in the Echo/Airo User’s Manual, pages 32-33).
 - d. Note: If some fans are missing, have the customer check each one to make sure the DIP switches are set properly on each fan box. See step 9 of the filtration installation procedure in the User’s Manual, page 21).
 - e. If the component is still missing, refer the customer to tech support at Erlab or Labconco as appropriate.

- 3) **“I cannot get the reconfiguration completed!”** (this can happen at initial installation and later with replacement of the acid sensor, filters or other service work)
 - a. Which step of the reconfiguration process are you on? Do you have the User’s Manual open to the correct page?
 - b.

Chapter 3: Getting Started

Have you completed all previous steps of configuration? If unsure, start over at the very beginning by deleting the configuration and creating a new one. Start at step 4 of the reconfiguration process in the User's Manual, page 31.

- c. Refer to the User's Manual and follow each step, step-by-step with patience and attention.
- d. If they continue to have difficulties, refer to tech support at Erlab to complete the configuration.

During operation of the fume hood:

- 4) **“The hood is in alarm, what do I do?”**
 - a. Ask the caller to please read the screen to see what the alpha-numeric alarm code is (i.e. 8S, 8Q, 8K, etc.). They may need to press the OK button to see the code.
 - b. Refer to the GFH alarm code list (next page) to see what the alarm is, possible causes and recommended actions (e.g. lower sash, replace acid sensor, replace filters, etc.).
 - c. Re-booting the GFH computer can remove a momentary alarm situation. Ask the customer to cycle power to the hood to see if that resets the issue. Either unplug the hood completely, or simply pull out the black fuse holder in the left-hand end of the GFH Command Module (the Erlab box with the display screen). Wait 15 seconds and then restore power. The hood will go through a re-boot and takes a couple of minutes to be ready. Please be patient.
 - d. If none of the above resolve the issue, refer the customer to tech support at Erlab or Labconco as appropriate.

- 5) **“The hood is in filter saturation alarm and its brand new! What do I do?”**
 - a. The saturation detection sensors are likely not yet fully burned in. The hood should be left running for 24 to 48 hours to allow the sensors and their chamber to fully purge and burn in.

- b. If it has been running for at least that amount of time, check to make sure the solvent sensor trigger set point is correct. Using an Administration or Maintenance access card, go into the Hood Status menu and scroll down to the “Semicon Sensor” sub menu. Confirm that the “Trig. M” value (e.g. 3600 mV) matches the GFH Settings sheet that was provided with the hood.
 - c. Sometimes the sensor tubing is not properly connected to each and every fan box. Have the customer remove the front access panel and confirm that the clear tubing coming from the Command Module is connected to the first fan and each fan after that (fan quantity depends upon hood width).
 - d. Cycle power with the fuse holder or unplugging the hood to see if that resets the issue. The hood will re-boot, be patient.
 - e. If the hood is still in saturation alarm, refer to tech support at Erlab or Labconco as appropriate.
- 6) **“The hood is in mis-match alarm (9A), why?”**
- a. The Command Module scans each electrical device periodically to make sure it is still connected and working properly. Sometimes, due to the timing of the scan, it does not see a component and sounds the mismatch alarm (code “9A”).
 - b. First, cycle power with the fuse holder or unplugging the hood to see if that resets the issue. The hood will re-boot, be patient.
 - c. If the mismatch alarm persists, have them insert the Maintenance access card and press the OK button with the cursor next to the “Hardware Mismatch” menu on the screen. See step 1 of the Re-configuration Process in the User’s Manual, pages 29-30.
 - d. Have them double check that the electrical connection to the missing component is complete (fan, light, sash sensor, etc.). Unplug and plug back in the connection.
 - e. Note: the alarm will not automatically clear. You must reboot the hood (fuse or power cord) to get the Command Module to rescan and clear the alarm.
 - f. If the hood is still in mismatch alarm, refer to tech support at Erlab or Labconco as appropriate.

Note: To conclude, these six tech support scenarios represent over 95% of the calls we receive. If, however, the customer cannot resolve the issue (or is experiencing an issue not listed above) please don’t hesitate to get tech support at Erlab and/or Labconco headquarters involved immediately.

Certifying the Protector Filtered Fume Hood

The filtered hood gives you the flexibility to change the airflow at the sash opening of your hood. To determine the actual face velocity at the sash opening, airflow velocity readings will need to be taken. This should be done across the sash opening of the hood in accordance with the *Industrial Ventilation Manual* section on laboratory hoods (see *Appendix E: References*). Labconco recommends an average face velocity at the sash opening of 60 to 100 feet per minute. Consult Chapter 2 for proper airflow volumes for your particular model.

Your Protector Fume Hood has been tested at the factory per ASHRAE 110-1995. All hoods achieve an “as manufactured rating” of less than 0.05 part per million (ppm) at 4 liters per minute (lpm); AM<0.05 (consult Labconco for individual fume hood ratings). For “field use” ASHRAE testing contact Labconco Sales Engineering Team or Customer Service for a certified on-site contractor. A “field use” ASHRAE method is used with isopropyl alcohol and a full report and method is available upon request and posted on Labconco’s website.



NOTE: Face velocity profiles and smoke testing should be done periodically to ensure safe performance.

NOTE : Les profils de flux frontal et les tests de fumée devraient être régulièrement faits pour garantir une utilisation en toute sécurité.

CHAPTER 4

PERFORMANCE FEATURES AND SAFETY PRECAUTIONS

Performance Features

Labconco has combined its patented (U.S. Patent No. 6,461,233) fully featured, containment-enhancing Protector Hood design with Neutrodine filtration technology to deliver a multi-use fume hood that requires no ducting. The Protector Filtered Hood provides safety, energy savings, and adaptability to ever-changing lab spaces.

The Protector Filtered Fume Hood is designed to meet the needs of the laboratory scientist at OSHA-approved velocities from 60 to 100 feet per minute. The filtered fume hood has been designed to effectively contain toxic, noxious, or other harmful materials when properly installed. A fully featured by-pass hood with Neutrodine universal filter technology enables this filtered hood to maintain safe airflow with excellent filtration efficiency. Accessory Sash Reduction Wings are also available. Airflow is diverted behind the front panel and under the air foil to help control fluctuations in face velocity, which occur as the sash is closed. The filtered hood is SEFA 9 compliant as a DH3 for ductless hoods and ductless enclosures with back-up safety filters.

The Benefits of Filter Technology

1. **Neutrodine filtration** takes the guesswork out of carbon filter choices allowing simultaneous handling of solvents, acids and bases with one comprehensive filter.
2. **Backup secondary filter** provides added safety after breakthrough and until filter change can occur.
3. **Sensor package** detects filter saturation detection, temperature, sash position and user identification. Alarms sound when unsafe conditions are detected.

Chapter 4: Performance Features & Safety Precautions

4. **Intelligent filter identification** indicates type (HEPA or Neutrodine) and status (primary or secondary) to prevent saturated filter reinstallation risk.
5. **Identification card** is required for operation to control access to specified users.
6. **Available with gGuard⁺ software** to monitor, manage and provide data via email to a designated facility manager.
7. **SEFA 9 Compliant as a DH3. Passes AFNOR NF-X 15-211.**

The Benefits of Fume Hood Technology

8. **Patented* Clean-SweepTM Sash Handle and Sash Tracks and Eco-FoilTM Air Foil** maximize containment.
9. **Corrosion-resistant panelized fiberglass liner** with option for glass sides and back provide durability for long life.
10. **Fully-closing, vertical-rising sash** opens to 28" high for loading. **No hinges to impair visibility.**
11. **Operating Height of 16" high for energy savings** with defeatable sash stop. Sash Stop adjustable to other heights such as 10" through 18" to meet 100 feet per minute local requirements when needed.
12. **31" deep interior working space**
13. **Maintains 60-100 fpm face velocity** but, unlike traditional hoods, has no ducted exhaust requirements.
14. **Accommodates up to four electrical duplex receptacles and eight services fixtures.**
15. **Available in 37.7" depth and 4', 5', 6' and 8' widths. 3' only available in 31.7" depth.**
16. **Passes ASHRAE 110-1995 Fume Hood Containment Tests.**
17. **By-pass airflow design** ensures relatively stable face velocities.
18. **Large usable interior work depth and interior height of 48"** provides ample working space.
19. **Exterior access cover plates** are removable for easy access to plumbing valves and sash adjustment hardware when access through the sides is not available.
20. **Lift-AwayTM front, side, and rear panels** provide easy access to electrical wiring, sash weights, and lighting fixtures.
21. **Energy efficient fluorescent lighting** is located behind a plastic shield. The factory-wired instant start lighting is serviceable from outside the hood cavity and provides up to 63 foot candles inside the work area.
22. **Eco-Foil Air Foil** allows air to sweep the work surface for maximum containment. Flush foil is also available. The air foils have Clean-SweepTM openings that create a constant barrier from contaminants. In addition, should the operator inadvertently block the airflow entering, the air continues to enter from under the air foil and through the Clean-Sweep openings.
23. **Streamlined corner posts** provide maximum visibility and the flexibility to add services after installation.
24. **All hoods are factory prepared for up to 8 service fixtures, except small Airo 54.2" height units which have 6.**

25. **Duplex electrical receptacles** are mounted on the right and left corner posts as requested. Receptacles are factory-wired to hood single point junction boxes.
26. **Shipped mostly assembled** and eliminates the need for costly onsite assembly. The control panel, sash sensor, and temperature sensor wiring are pre-assembled for convenience.
27. **Includes a sash position alarm and a velocity alarm** should the fan speed RPM's be compromised.
28. **Accessory Guardian™ Digital Airflow Monitor** continuously monitors face velocity. An audio/visual alarm alerts the user to low airflow conditions. The corner post is factory prepared to accommodate the Guardian Digital Monitor (sold separately).
29. **Frame of powder-coated steel and aluminum** is durable and corrosion resistant.
30. **Spillstopper™ Solid Epoxy Work Surface** is dished to contain spills. (Work surface is sold separately).
31. **Sound pressure of less than 60 dB(A)** at operating height for quiet operation. Less than 48 dB(A) with sash closed.

Chapter 4: Performance Features & Safety Precautions

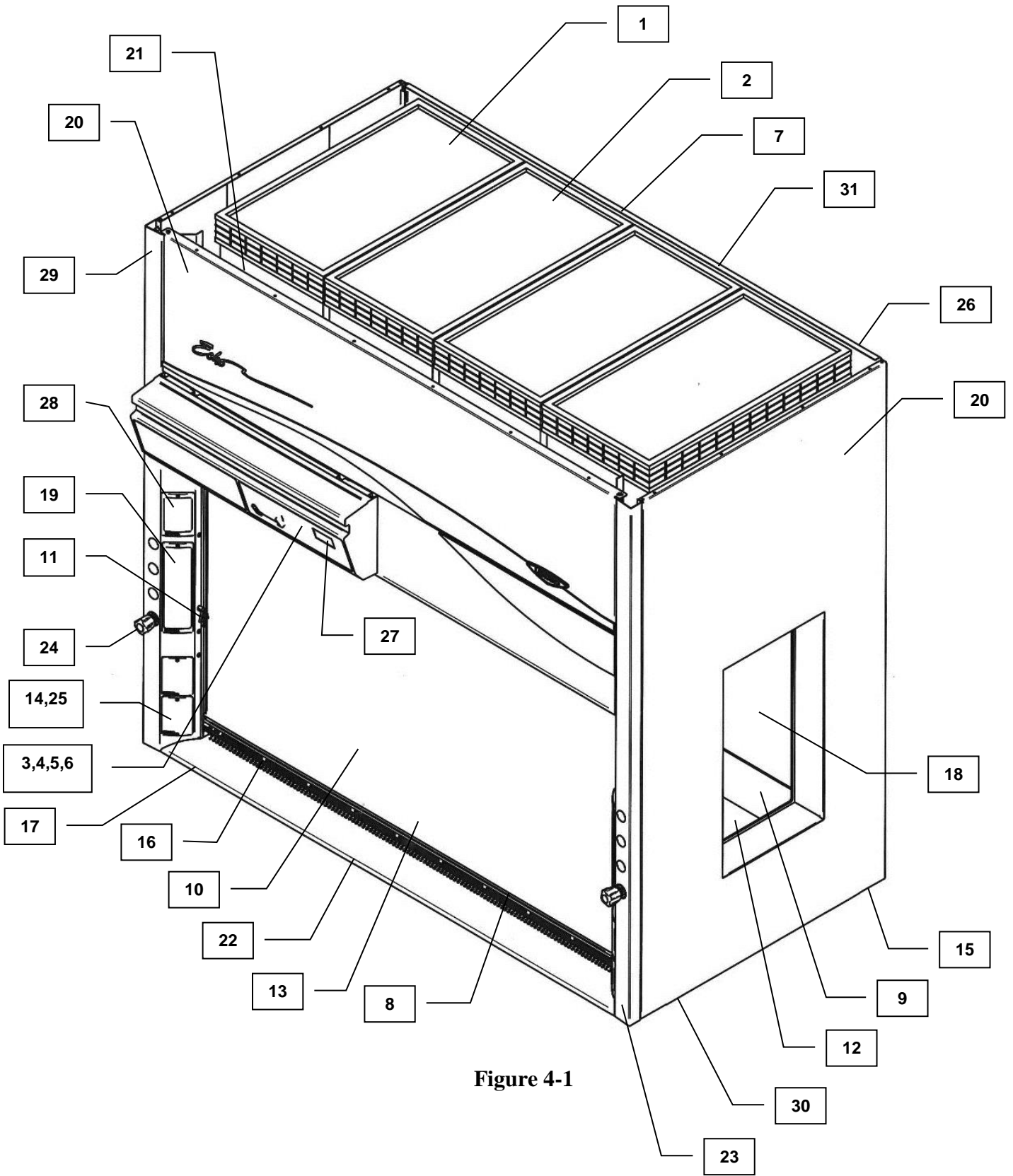

Figure 4-1

Safety Precautions



Although the filtered fume hood has been engineered to maintain optimum operator safety, caution should always be used while working in the hood. Prior to using the hood, check to make sure that the exhaust blower is operating and that air is entering the hood at its specified face velocity.

Bien que la hotte filtrée a été conçu pour maintenir une sécurité optimale de l'opérateur, la prudence doit toujours être utilisé tout en travaillant dans la hotte. Avant d'utiliser le capot, assurez-vous que le ventilateur d'échappement est en marche et que l'air entre dans la hotte à sa vitesse nominale spécifiée.

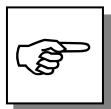

USE GOOD HOUSEKEEPING IN THE HOOD AT ALL TIMES. CLEAN UP SPILLS IMMEDIATELY WITH A MILD DETERGENT. PERIODICALLY CLEAN HOOD INTERIOR, INCLUDING FLUORESCENT LIGHT GLASS PANEL. REPLACE BURNED OUT LIGHT BULBS TO MAINTAIN MAXIMUM ILLUMINATION.



THE LAMP(S) IN THIS PRODUCT CONTAIN MERCURY

Manage in accordance with local disposal laws. DO NOT place lamps in trash. Dispose as a hazardous waste. For information regarding safe handling, recycling and disposal, consult www.lamprecycle.org

CETTE LAMPE DANS CE PRODUIT CONTIENT DU MERCURE

Éliminez ou recyclez conformément aux lois applicables. Pour de l'information concernant des pratiques de manipulation sécuritaires et l'élimination sécuritaire et le recyclage, veuillez consulter www.lamprecycle.org

DO NOT OVERLOAD THE WORK SURFACE WITH APPARATUS OR WORK MATERIAL. THE SAFE OPERATION OF THE LABORATORY HOOD IS BASED UPON HAVING PROPER AIRFLOW THROUGH THE STRUCTURE. DO NOT PLACE LARGE, BULKY OBJECTS SUCH AS BLOCK HEATERS, DIRECTLY ON THE HOOD WORK SURFACE. INSTEAD, ELEVATE THE OBJECT 2" TO 3" ON BLOCKS TO ALLOW A FLOW OF AIR UNDER THE OBJECT AND INTO THE LOWER REAR BAFFLE EXHAUST SLOT. ENSURE BLOCKS ARE LEVEL AND SECURED IN PLACE.



Avoid placing your head inside hood. Keep hands out of hood as much as possible.

Eviter de placer votre tête à l'intérieur de la hotte. Garder les mains à l'extérieur de la hotte le plus possible.

Always work as far back in hood as possible. It is best to keep all chemicals and apparatus 6" inside the front of the hood.

Toujours travailler aussi loin que possible de la hotte. Il est recommandé de garder tous les produits chimiques et appareils à 6 pouces à l'intérieur de l'avant de la hotte.

This hood does not feature explosion-proof electrical components. Therefore, use of flammable or explosive materials in quantities above the explosive limit are not recommended.

Cette hotte ne possède pas de composants électriques anti-explosion. Donc, l'usage de matériels inflammables ou explosifs dans les quantités au-dessus de la limite explosive n'est pas recommandé.

Do not work with chemicals in this hood without the fan system running and a face velocity of 60-100 fpm. Do not store chemicals in a fume hood.

Ne pas travailler avec des produits chimiques dans cette hotte sans le système de ventilateur en marche et une vitesse nominale de 60 à 100 pieds par minute. Ne rangez pas de produits chimiques dans une hotte.

The use of safety goggles, protective clothing, gloves, and other personal protective equipment recommended by your safety officer should be used.

L'utilisation de lunettes de sécurité, des vêtements de protection, des gants et autres équipements de protection personnelle recommandés par votre agent de sécurité doit être utilisé.

Perchloric acid use in this hood is prohibited.

L'usage d'acide perchlorique sous cette hotte est interdit.

High level radioisotope materials are prohibited for usage in this hood.

Les matériels d'isotope radioactif de haut niveau sont interdits à l'usage sous cette hotte.

Do not use with organophosphoric (insecticide) compounds, mercury, hydrogen cyanide, or highly exothermic reactions. High exothermic reactions and smoke generation require the use of a HEPA filter.

Ne pas utiliser avec (insecticides) composés organophosphorés, le mercure, le cyanure d'hydrogène, ou des réactions fortement exothermiques. Réactions exothermiques élevées et la production de fumée nécessitent l'utilisation d'un filtre HEPA.

The following compounds are not retained well: Helium and the Noble Gases, Hydrogen, Ethane, Ethylene Oxide, Methane, Carbon Monoxide, Carbon Dioxide, Nitrogen Monoxide, Propylene, Propyne, Propane, and Acetylene.

Les composés suivants ne sont pas bien conservés: l'hélium et les gaz nobles, hydrogène, d'éthane, l'oxyde d'éthylène, méthane, monoxyde de carbone, dioxyde de carbone, d'azote monoxyde, propylène, Propyne, propane et d'acétylène.

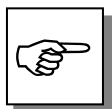

AVOID CROSS DRAFTS AND LIMIT TRAFFIC IN FRONT OF THE HOOD. AIR DISTURBANCES CREATED MAY DRAW FUMES OUT OF THE HOOD.



The use of heat-generating equipment in this hood without the fan system operating properly can cause damage to the hood. Most of the time, heated applications require a regular ducted fume hood.

L'utilisation d'équipements générant de la chaleur dans cette hotte sans le système de ventilateur fonctionnant correctement peut provoquer des dommages à la hotte. La plupart des applications en temps chauffé nécessitent une hotte canalisé régulière.

The Protector Filtered Hood should be certified by a qualified certification technician before it is initially used. The filtered hood should be re-certified whenever it is relocated, serviced or at least annually thereafter.

Chapter 4: Performance Features & Safety Precautions

Le Protecteur filtrée capot doit être certifié par un technicien qualifié avant de certification, il est d'abord utilisé. Le capot filtrée devrait être re-certifié à chaque fois qu'il est déplacé, la réparation ou au moins annuellement par la suite.

Ensure that the hood is connected to electrical service in accordance with local and national electrical codes. Failure to do so may create a fire or electrical hazard. Do not remove or service any electrical components without first disconnecting the hood from electrical service.

Assurez-vous que le capot est connecté au service électrique conformément aux codes électriques locaux et nationaux. Ne pas le faire peut créer un risque d'incendie ou électrique. Ne pas enlever ou de réparer des composants électriques sans d'abord débrancher la hotte du service électrique.

Proper operation of the filtered fume hood depends largely upon the hood's location and the operator's work habits. Consult the Reference Manual in *Appendix E*.

Le bon fonctionnement de la hotte filtrée dépend largement de l'emplacement de la hotte et les habitudes de travail de l'opérateur. Consulter le Manuel de Référence dans l'Annexe E.

If the hood is not operated as specified in this manual, it may impair the protection it provides.

Si la hotte ne est pas utilisé comme spécifié dans ce manuel, il peut porter atteinte à la protection qu'il offre.

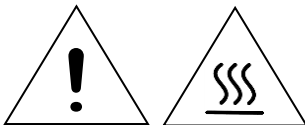

Do not touch the fan motors. The surfaces of the motor can become hot, cause burns or cause damage.

Ne touchez pas les moteurs de ventilateur. Les surfaces du moteur peuvent devenir chauds, causer des brûlures ou causer des dommages.



Do not position the filtered fume hood so that it is difficult to operate the main disconnect device.

Ne pas positionner la hotte filtrée de sorte qu'il est difficile de faire fonctionner le dispositif de déconnexion principal.



To prevent the possibility of minor injury keep hands and fingers clear of pulleys or sprockets at the top of the four corners.

Pour éviter la possibilité de blessure mineure garder les mains et les doigts de poulies ou pignons au sommet des quatre coins.



The filtered hood should be recertified whenever it is serviced or at least annually thereafter.

La hotte doit être filtrée recertifié quand il est desservi ou au moins annuellement par la suite.

Use of an open flame must be avoided. Open flames may disrupt the airflow patterns in the cabinet and cause a fire hazard with volatile chemicals and solvents.

Utilisation d'une flamme doit être évitée. Flammes nues peuvent perturber les modèles de flux d'air dans le boîtier et provoquer un risque d'incendie avec des produits chimiques et des solvants volatils.

Handle new and used filters with care during installation and removal. Refer to instructions in this manual for proper handling of filters.

Poignée de nouveaux filtres et utilisés avec précaution lors de l'installation et l'enlèvement. Consulter les instructions dans ce manuel pour la manipulation correcte des filtres.

Saturated carbon filters and HEPA filters are to be disposed of as hazardous waste. The user is responsible for recording the chemicals adsorbed or removed by the filters and disposing of them properly.

Filtres de carbone saturés et les filtres HEPA doivent être éliminés comme des déchets dangereux. L'utilisateur est responsable de l'enregistrement des produits chimiques adsorbé ou enlevés par les filtres et de les jeter correctement.

Use in areas where only trained users have access to the filtered hood. Any new users must be trained and should also read this User's Manual.

Utilisez dans les zones où seuls les utilisateurs formés ont accès à la hotte filtré. Les nouveaux utilisateurs doivent être formés et doivent également lire le manuel de l'utilisateur.

Do not use the filtered hood in a poorly ventilated area. If the hood is to be used in a confined space, make sure the space is well ventilated and the concentration of toxic contaminants cannot accumulate greater than the exposure limit/TWA.

Ne pas utiliser la hotte filtré dans un endroit mal ventilé. Si la hotte doit être utilisé dans un espace confiné, assurez-vous que l'espace est bien ventilé et la concentration des contaminants toxiques ne peut accumuler plus grande que la limite d'exposition / TWA.

The warning properties (i.e., odor, taste) of the volatile organic compounds or other material being used in the enclosure must be adequate to provide an early indication that the carbon filter may be saturated. In other words, it is best when the odor threshold is less than the exposure limit/TWA.

Les propriétés d'alerte (par exemple, l'odeur, goût) de la ou des composés organiques volatils autres matériaux utilisés dans l'enceinte doit être suffisante pour fournir une première indication que le filtre à charbon peut être saturé. En d'autres termes, il est préférable lorsque le seuil d'odeur est inférieure à la limite d'exposition / TWA.

Highly toxic vapors, unknown reactions, hazardous particulates, or processes generating high levels of contaminants are not intended for use in the filtered hood.

Vapeurs très toxiques, réactions inconnus, des particules dangereuses, ou de procédés produisant des niveaux élevés de contaminants ne sont pas destinés à être utilisés dans la hotte filtrée.

Only chemicals which can be safely adsorbed/treated with the specific carbon-based filters installed or removed by HEPA filters are appropriate for use in this enclosure.

Seuls les produits chimiques qui peuvent être en toute sécurité adsorbé / traitées avec les filtres à base de carbone spécifiques installées ou supprimées par des filtres HEPA sont appropriés pour une utilisation dans cette enceinte.

Use the smallest possible quantity of chemical(s) within the filtered hood and never exceed the amount which can be effectively adsorbed by the filters before breakthrough.

Utilisez la plus petite quantité possible de produit chimique (s) dans le capot filtrée et ne jamais dépasser le montant qui peut être efficacement adsorbé par les filtres avant de percée.

Leave the blower on for at least one minute after work in the filtered hood has been completed.

Laissez le ventilateur pendant au moins une minute après le travail dans la hotte filtrée a été achevée.

If a chemical is spilled on the work surface DO NOT switch off the fans until all traces of the chemical has been removed.

Si un produit chimique est renversé sur la surface de travail Ne éteignez pas les fans jusqu'à ce que toutes traces de la substance chimique a été supprimé.

Make sure filters are installed prior to each use. Remove the front panel to install the filters.

Assurez-vous que les filtres sont installés avant chaque utilisation. Retirez le panneau avant pour installer les filtres.

If the fan fails during use, chemical processes should cease and the area should be vacated and ventilated before servicing the blower.

Si le ventilateur échoue lors de l'utilisation, les processus chimiques doivent cesser et la zone doit être libéré et ventilé avant de réparer le ventilateur.

Always refer to the NIOSH Pocket Guide to Chemical Hazards before proceeding. For additional help with filter and chemical selection, contact Labconco at 800-821-5525 or 816-333-8811.

Toujours se référer à l'NIOSH Pocket Guide to dangers des produits chimiques avant de procéder. Pour une aide supplémentaire avec filtre et de sélection chimique, contacter au 800-821-5525 ou Labconco 816-333-8811.

The surface of the HEPA filter is fragile and should not be touched. Care must be taken to avoid puncturing the HEPA filter during installation or normal operation. If you suspect that a HEPA filter has been damaged DO NOT use the filtered hood; contact a local certification agency or Labconco.

La surface du filtre HEPA est fragile et ne doit pas être touché. Des précautions doivent être prises pour éviter de perforer le filtre HEPA pendant l'installation ou le fonctionnement normal. Si vous soupçonnez qu'un filtre HEPA a été endommagé NE PAS utiliser le capot filtré; communiquer avec un organisme de certification local ou Labconco.

Chapter 4: Performance Features & Safety Precautions

The HEPA filter in the filtered hood will gradually accumulate airborne particulate matter from the room and from work performed in the enclosure. The rate of accumulation will depend upon the cleanliness of the room air, the amount of time the filtered hood is operating and the nature of work being done in the filtered hood.

Le filtre HEPA dans la hotte filtrée accumulera progressivement particules aéroportées de la salle et des travaux exécutés dans l'enceinte. Le taux d'accumulation dépend de la propreté de l'air ambiant, la quantité de temps le capot filtrée est en marche et la nature des travaux effectués dans la hotte filtré.

Tag the filtered hood with appropriate warning if any filters have been removed for service.

Marquer le capot filtrée avec avertissement approprié si des filtres ont été retirés du service.

CHAPTER 5

USING THE PROTECTOR

FILTERED HOOD

Access Cards

The Labconco Protector Filtered Hood with Neutrodine Filtration Technology can only be operated with the insertion of a personalized RFID (radio frequency identification) card. 11A and 8D alarm codes.

1. User: Allows full operation for approved applications and activates all safety features.
2. Administrator: Offers unrestricted access to important historical data such as recorded usage. Can assign users.
3. Maintenance: A total access card for calibration, troubleshooting and easy service.

Figure 5-1
Access Cards, Display,
and Operating Buttons

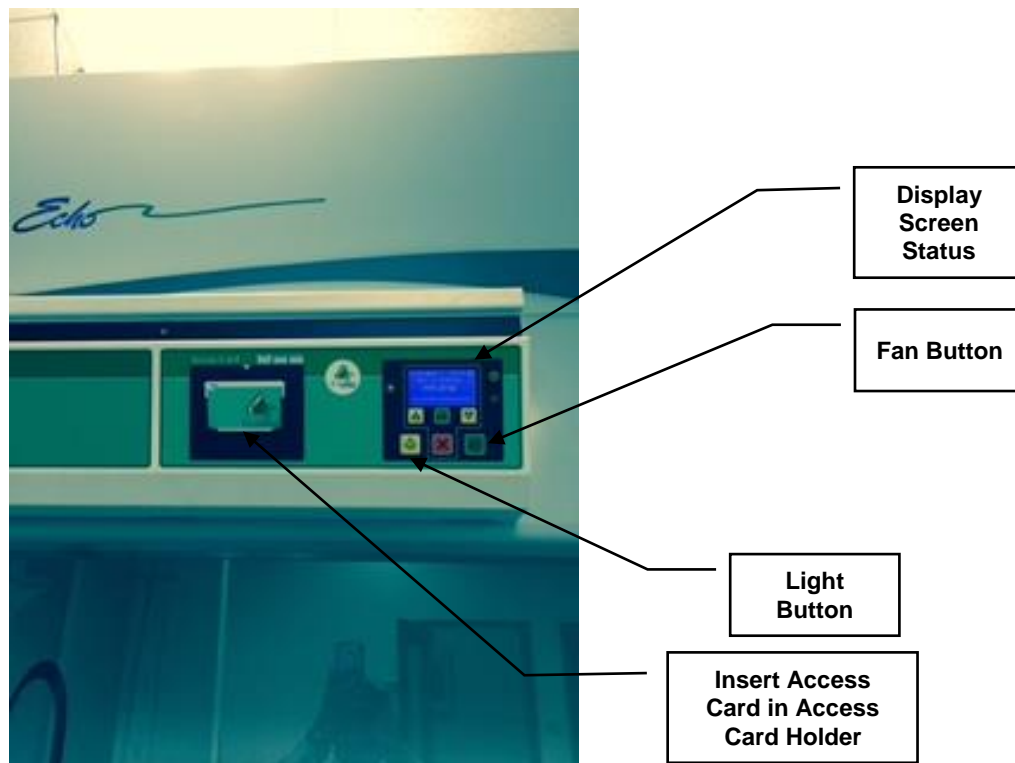

Starting the Filtered Hood

1. To start the filtered hood, insert an access card and press the “Fan” button. You can also validate performance by listening to the fans, reviewing the display, and/or watching smoke drawn into the hood face opening.
2. To turn the fluorescent light on with an access card already inserted, press the “Light” button.

Operating the Vertical-Rising Sash

Because of the Protector Filtered Hood counterbalanced sash mechanism, it will take only a few pounds of force to move the sash up or down, and you can operate the sash smoothly with one or two hands positioned anywhere along the handle. The vertical-rising sash may be raised to a maximum 16" operating height for proper airflow between 60-100 fpm. The airflow requirements should be sized for the 16" operating height. The sash stops allow the loading height to be increased to 28" only for loading equipment. See *Chapter 2* for airflows.

The Modular Neutrodine Filtration

Under normal conditions, the air quality at the safety filter (upper most position per Figure 5-2) is purer than the laboratory. The embedded sensors inform the user when the air quality after passing through the first layer of modular Neutrodine filters contain an excessive level of chemicals called chemical breakthrough. Neutrodine filtration utilizes a universal media allowing simultaneous handling of solvents, acids, and bases with one filter with spaces to enhance adsorption. The maximum acceptable concentration of contamination at the filter exhaust, to comply with the NFX 15211, should never exceed 1% of the TLV of the exhausted chemical. In order to provide a reliable solution to monitor the exhausted air quality, the sensors were tested within a large range of conditions over a period of several years. These sensors are located on the control panel and air is sampled in two filter stages, the primary and the safety filter, in order to inform the user when the primary filter is saturated and can no longer adsorb additional contaminants. The filtered hood operates without risk as the user is always protected by the redundant safety backup filter.

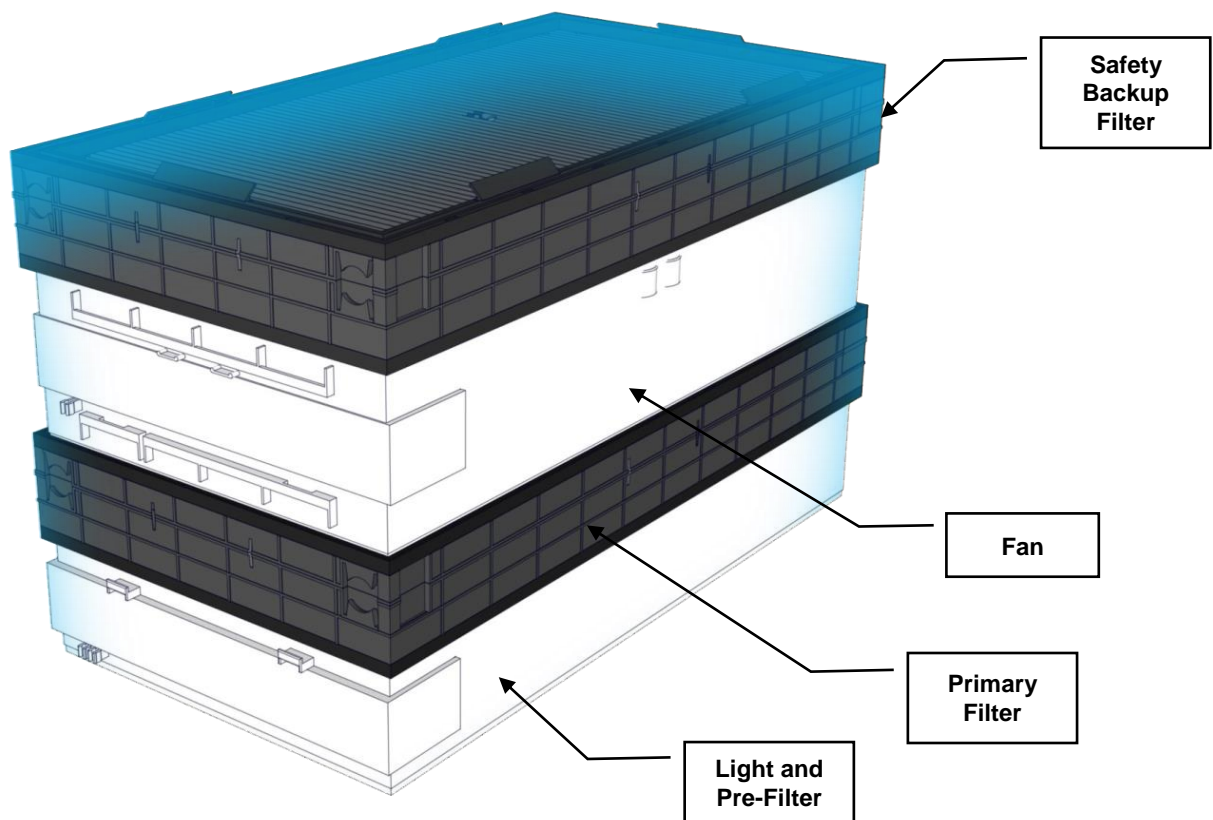

Figure 5-2
The Modular Neutrodine Filtration Technology

Detecting a Breakthrough

Detecting a breakthrough of the lower primary filter is automatically completed with a broad sensor, a target acid gas sensor, and a lab ambient air sensor.

Broad Sensor (Solvents)

The first sensor is based on a semi-conductor metal oxide sensing chip with integrated heater. In the presence of detectable gas, sensor concentration increases with electrical output signal which corresponds to the gas concentration. The first sensor detects a large range of chemicals, such as solvents, but is not sensitive to inorganic acids and some halogenated chemicals.

**Figure 5-3
Broad Sensor**

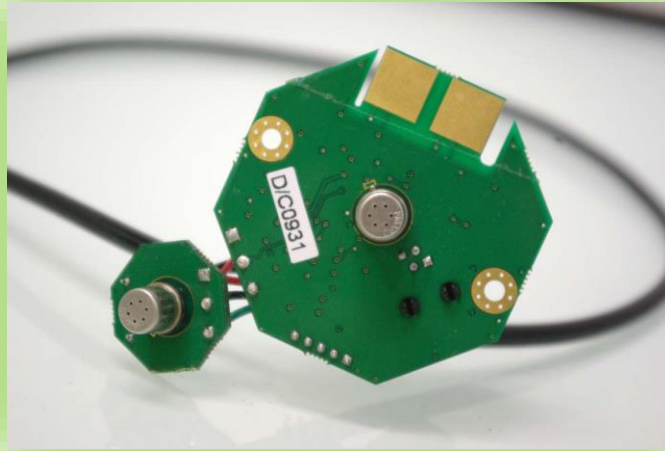

Target Acid Sensor

The second sensor completes the electrochemical sensor array to detect inorganic acids and/or bases. The target sensor contains an electrolyte and is similar to an electrode used to measure pH or ions in water. When a target chemical such as an inorganic acid migrates into the electrolyte, the potential of the electrode is modified signaling an alarm condition.

**Figure 5-4
Target Sensor**

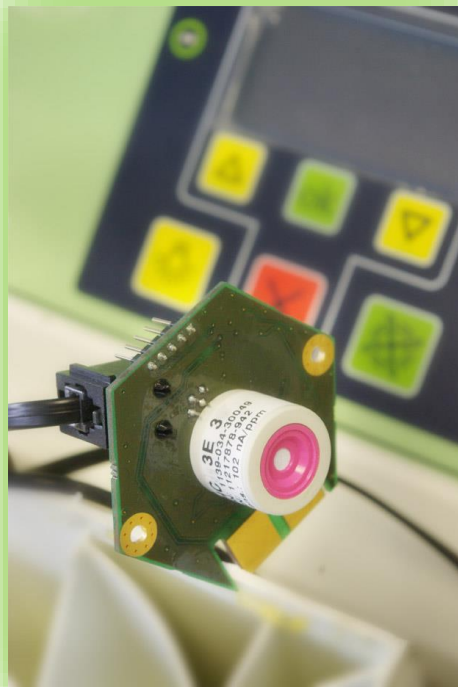

Lab Ambient Air Sensor

The third sensor is identical to the first sensor commonly referred to as the solvent sensor. This sensor functions like the broad sensor and is used to monitor the air quality in the lab.

Figure 5-5
Lab Ambient
Air Sensor

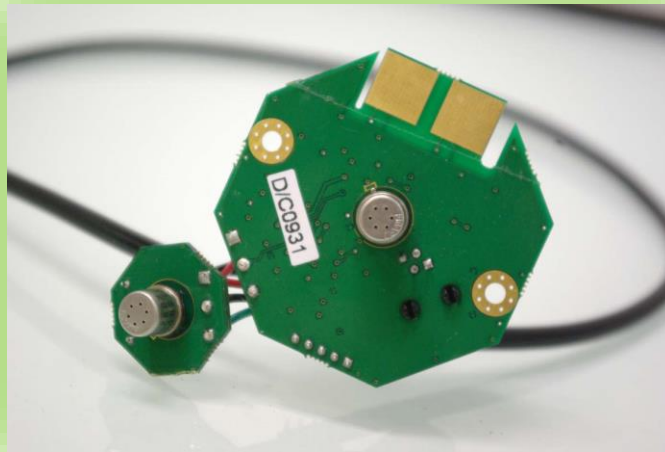

Communication

The Protector Filtered Hood has three systems of communication with one system standard and two systems optional as indicated below:

1. The onboard computer and display screen (see Chapter 8 for complete alerts and alarms).
2. Optional gGuard software add on (see Appendix E).
3. Optional BACnet hardware add on (see Appendix F).

Technology Alerts

The following technology alerts are discussed, recognized and logged by each Protector Hood with exception to the BACnet. For additional details on alerts and alarms, see *Chapter 6: Maintenance* or *Chapter 8: Troubleshooting*.

- **8S-Sash Position Alert** – Operating position programmed to campus or company standard during installation. Moving sash higher set off alert.
- **8V, 8W & 8X High Temperature Alerts (3)** – First level: Enclosure temperature exceeded +104°F. Check all heat sources. Second level: Critical temp +140°F. Fans stopped. Alert maintenance and fire personnel. Final alarm: Temperature Sensor out of order.

Chapter 5: Using the Protector Filtered Hood

- 8Y & 9A System Alerts – (1) Embedded memory is full. (2) Configuration Mismatch.
- XXXX Administrator Alerts – Programmed and sent to hood.
- 8G Fan Adjustment problem – Setpoint in RPM cannot be met.
- 8H Fan out of order – Rotation speed less than 800 RPM.
- 8R Programmed reminders – For manual checks for filter integrity.
- 8T LPR – Programmed alarm.
- 8U RFID – B.O.D. alarm. Neutrodine born on date expiration.
- 8J, 8K & 8L Broad Sensor Alarm – 3 levels of alerts. First Alert: Neutrodine Filters may be nearing ending of life. Second Alert: sensing threshold permanently exceeded. Time to replace filters. Third Alert: Sensor out of order.
- 8M, 8N, 8P & 8Q Targeted Sensor Alarm – Same as alert sequence as above plus Acid Sensor end of life alert.
- Silent Alarm – For ambient air sensor which goes to gGuard only.

User Options and Approved Chemicals

- Optional gGuard[®] Software – See Appendix E.
- Optional BACnet hardware add-on – See Appendix F.
- Secure Mode Configurations – See Appendix G.
- Chemical Guide (approved list of chemicals) – See Appendix H.

Working in Your Protector Filtered Fume Hood

Planning

- Thoroughly understand procedures and equipment required before beginning work.
- Arrange for minimal disruptions, such as room traffic or entry into the room, while the hood is in use.

Start-up

- Turn on light and filtered hood fans.
- Slowly raise the sash.
- Allow the hood to operate unobstructed for 1 minute.
- Wear a long sleeved lab coat and rubber gloves. Use protective eyewear. Wear a protective mask if appropriate.

Loading Materials and Equipment

- Only load the materials required for the procedure. Do not overload the hood.
- Do not obstruct the front air foil.

- Large objects should not be placed close together and spaced above the work surface to permit airflow to sweep under the equipment.
- After loading the hood, wait one minute to purge airborne contaminants from the work area.

Work Techniques

- Keep all materials at least 6 inches inside of the sash, and perform all contaminated operations as far to the rear of the work area as possible.
- Segregate all clean and contaminated materials in the work area.
- Avoid using techniques or procedures that disrupt the airflow patterns of the hood.

Final Purging

- Upon completion of work, the hood should be allowed to operate for two to three minutes undisturbed, to purge airborne contaminants from the work area before shutting down blower.

Unloading Materials and Equipment

- Objects in contact with contaminated material should be surface decontaminated before removal from the hood.
- All open trays or containers should be covered before being removed from the hood.

Shutdown

- Turn off the light and filtered hood fans, then close the sash.

CHAPTER 6

MAINTAINING THE

PROTECTOR FILTERED HOOD

Required maintenance includes routine replacement of the Neutrodine carbon filters, HEPA filters, and fluorescent light. The security and communication options are also listed.

Review this chapter on maintenance for the following:

- Routine Maintenance
- Initial Certification
- Re-Certification
- User Alarm Code List
- Tool List
- Neutrodine SDS for disposal
- Partial Filter Replacement Procedure
- Reconfiguration Process (listed in Chapter 3) – needed for most maintenance procedures.
- Light and/or Circuit Board Replacement
- Fan and/or Circuit Board Replacement
- Fan Box Replacement
- Electro (Acid/Gel) Sensor Replacement – required every 2 years.
- Secure Mode (see Appendix G)
- gGuard Checklist and Software Option (see Appendix E)
- BACnet Checklist Option (see Appendix F)

Routine Maintenance Schedule

Weekly

- Wipe down the interior surfaces of the filtered hood with a suitable dish soap, solvent, disinfectant, or cleaner, depending upon the usage of the unit and allow to dry.
- Using a damp cloth, clean the exterior surfaces of the filtered hood, particularly the front and top to remove any accumulated dust.
- Operate the fan system, noting the airflow velocity on the display and airflow through the filtered hood using a source of visible smoke.

Quarterly (or more often as required)

- Determine the actual airflow face velocity through the sash opening of the filtered hood where the average reading should be at the specified velocity. (Use calibrated thermal anemometer or other approved apparatus).
- Replace **carbon** filters when chemical breakthrough is indicated by the primary broad organic sensor, target acid gas sensor or time. See “Partial Filter Replacement” section of this manual in *Chapter 6*.
- All weekly activities.

Annually

- Replace lights, if necessary.
- Replace **HEPA** filters if the face velocity drops below the recommended speed as the airflow alarm alerts you.
- Have the enclosure validated by a qualified certification technician. See Certification and Recertification in *Chapter 6*.
- All quarterly activities.

Initial Certification

The filtered hood has been designed for an inflow velocity of 60-100 fpm. The filtered hood should be certified for the proper inflow velocity required by your Safety Officer.

Re-Certification

Under normal operating conditions, the filtered hood should be recertified at least annually if serviced. The certifier should perform the following tests.

- Airflow Velocity Test

In addition, the following test should also be performed at the user’s discretion:



- Smoke Test to determine proper airflow patterns

User Alarm Code List

Listed next is an overview of control panel functions and alarm codes with their meaning, causes, and solutions.

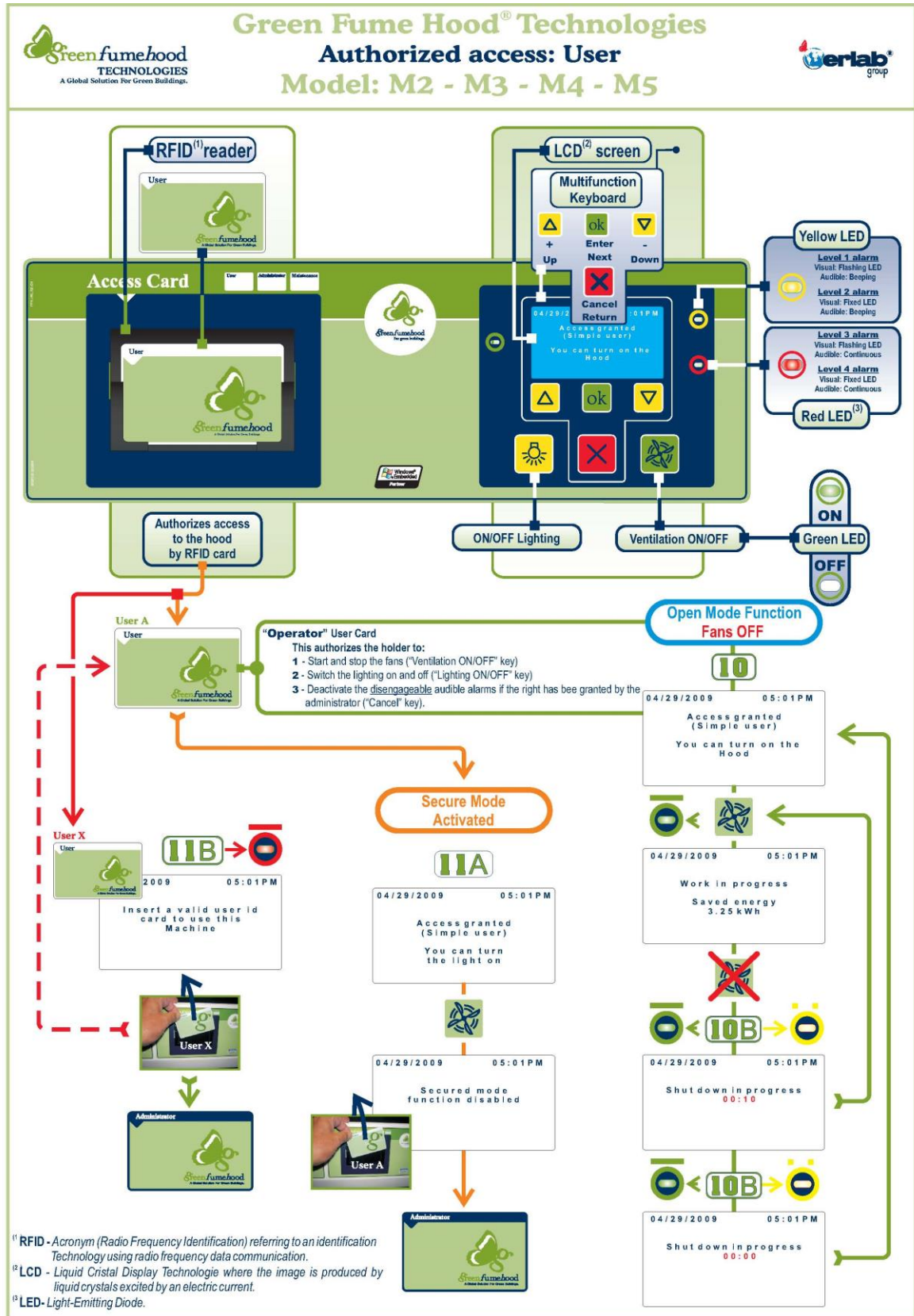
Chapter 6: Maintaining the Protector Filtered Hood



<div style="display: flex; justify-content: space-between; align-items: center;">  <div style="text-align: center;"> <h3>Alarms</h3> <h2>Causes and solutions</h2> <h1>For Green Fume Hood® Technologies</h1> <h2>Model: M2 - M3 - M4 - M5</h2> </div>  </div>							
Number of the alarm	Causes	Level of the alarm	Visual alarm	Audible alarm	Alarm Message	Clearable alarm	Solutions
11A	Keyboard used by an unauthorized user (or unauthorized access card in the RFID card reader)	4	Fixed Red	Intermittent	Alarm 11A To use the hood, insert an authorized user card	NO	Place an authorized card in the RFID Card Reader
8D	This alarm has priority even though it is at level 3. Access card removed while the hood is in use.	3	Flashing Red	Continuous	Alarm 8D Reinsert card. Emergency stop in 00:XX	NO	Reinsert an authorized card into the RFID Reader
8G	Fan adjustment problem.	2	Flashed Yellow	Intermittent	Alarm 8G Fan X: low rpm speed. Call Maintenance	YES	Call Maintenance
8H	Fan out of order. Rotation speed less than 700 rpm. Faulty fan management electronic card or poor contact of the fan connexion cable	4	Fixed Red	Continuous	Alarm 8H Fan X: out of order. Call Maintenance	YES	Fan X: out of order. Call Maintenance
8J	Semiconductor sensor alarm threshold temporarily exceeded for longer than the "Semiconductor sensor alarm delay". Time configured in minutes.	2	Flashed Yellow	Intermittent	Alarm 8J Semicon S. alarm: main Neutrodine filters near end of life	YES	Total replacement of main Neutrodine filters imminent
8K	Semiconductor sensor alarm threshold permanently exceeded. Saturated Neutrodine filter modules	4	Fixed Red	Continuous	Alarm 8K Semicon S. alarm: Replace main Neutrodine filters	YES	Total replacement of main Neutrodine filters
8L	Faulty Semiconductor sensor printed circuit board.	1	Flashing Yellow	Intermittent	Alarm 8L Semicon Sensor out of order: Call Maintenance	YES	Call Maintenance
8M	Electrolytic sensor alarm threshold temporarily exceeded for longer than the "Electrolytic Sensor alarm delay". Time configured in minutes.	2	Flashed Yellow	Intermittent	Alarm 8ME Electro S. alarm: main Neutrodine filters Near end of life	YES	Total replacement of main Neutrodine filters imminent
8N	Electrolytic sensor alarm threshold permanently exceeded. Saturated filter modules	4	Fixed Red	Continuous	Alarm 8N Electro S. Alarm: Replace main Neutrodine filters	YES	Total replacement of main Neutrodine filters
8P	Faulty electrolytic printed circuit board.	1	Flashing Yellow	Intermittent	Alarm 8P Electro Sensor out of order: Call Maintenance	YES	Call Maintenance
8S	Sash open too high: Sash opening greater than the configured alarm threshold.	2	Flashed Yellow	Intermittent	Alarm 8S Safety compromised: Lower the sash	YES	Lower the sash
8R	NFX 15-211 Neutrodine Filter Routine Check. Maintenance Alarm	2	Flashed Yellow	Intermittent	Alarm 8R NFX 15-211 Neutrodine Filter Routine Check. Call Administrator	YES	Refer to the appropriate section in Administrator Manual
8T	The LP Report filter expiration date has been reached	4	Fixed Red	Continuous	Alarm 8T LP Report predicted filter end of life alert	YES	Total replacement of main Neutrodine filters
8U	Neutrodine filter shelflife exceeded	4	Fixed Red	Continuous	Alarm 8U Neutrodine lifecycle complete. Change main filters	YES	Total replacement of main Neutrodine filters
8Q	"End of electrolytic sensor lifetime" alarm	4	Fixed Red	Continuous	Alarm 8Q Replace Electro Sensor	YES	Replace Electro Sensor
8Z	Activated 6 weeks before "End of electrolytic sensor lifetime" alarm	2	Flashed Yellow	Intermittent	Alarm 8Z Electro Sensor end of life	YES	Replacement Electro Sensor imminent
Xxxx	Alarm triggered remotely by safety officer/administrator via gGuard Software.	Determined by the administrator	According to the established level	According to the established level	1-Stop Handling 2-Contact safety officer 3-Lower the sash 4-Warning: Semicon sensor detection in laboratory 5-Warning: Electro sensor detection in laboratory	NO	Contact safety officer/administrator
8Y	Memory Full	3	Flashing Red	Continuous	Alarm 8Y Embedded Memory full. Call Administrator	YES	Empty history file. Contact safety officer/administrator
9A	Configuration does not comply with the factory configuration	4	Fixed Red	Continuous	Alarm 9A Hardware configuration Mismatch	NO	Check the position of the fan modules in relation to their address. Check the electrical connections. Reconfigure, procedure described in the appropriate section of the Maintenance manual
8V	40°C temperature alarm threshold exceeded in the enclosure	3	Flashing Red	Continuous	Alarm 8V Enclosure Temperature exceeded 40°C. Check heat sources	YES	Check heat sources
8W	Top priority alarm 60°C temperature alarm threshold exceeded in the enclosure	3	Fixed Red	Continuous	Alarm 8W Critical temperature. Fans stopped. Alert Maintenance/fire personnel	YES	Stop working in fumehood. If possible, turn off all heat sources. Completely close the sash. Alert all appropriate maintenance and fire personnel
8X	Faulty temperature sensor Printed circuit board.	1	Flashing Yellow	Intermittent	Alarm 8X Temperature Sensor out of order	YES	Replace the temperature sensor Printed circuit board.

Tool List

A list of tools that are needed for service operations.

All current models have a **#2 Phillips** for every tool listed below with the exceptions of the light/fan circuit boards and any OEM partner specific tools that are needed for the superstructure.

4mm Allen wrench..... For the two screws that attach the control module to the superstructure mounting bracket.

#2 Phillips screw driver..... For electrical cord set clamps to the back of controller.

Small slotted screw driver.....For the three set screws that hold down the power wires from cord set to back of controller.

Torx TX 10 For the two Electro/Acid Sensor circuit board screws.

Torx TX 20 For the six back panel screws that remove the rear panel of controller. All current controllers are Phillips.



5.5mm nut driver..... For the fan/light covers, and all the fan and light circuit boards.

OEM partner specific tools needed for any front panels on the superstructureCheck the superstructure manufacturer's documentation.

6ft A-frame ladder..... To safely have access to the technology for any service needs.



Neutrodine SDS for Disposal

NOTE: Note chemicals used and notify local authorities for proper disposal.

		Neutrodine® filtration technology		<i>Safety Data Sheet</i> <i>According to directive</i> <i>91/155/EC</i>	
1. Chemical product and company identification					
Product name	Neutrodine®				
Product usage	Filtration of chemical molecules				
Supplier	ERLAB INC. 388 Newburyport Turnpike Rowley, MA 01969 / USA Tel: +1 (978) 948-2216 / Fax: +1 (978) 948-3354 E-mail: gftsales@erlab.com				
2. Composition/Information on ingredients					
Substance/preparation	Substance				
Ingredients	Neutrodine®				
Chemical formulae	C				
CAS number	7440-44-0				
3. Hazards identification					
Hazardous reactions	May give CO and CO ₂ emanations in the event of a fire.				
Information pertaining to particular dangers for man and environment					
Carbon	Combustible product. Pollution due to the dispersion of spattered Biological risk for the medicinal carbons. To take medicine can be alleviated by the adsorbant capacity of activated carbon.				
4. First aid measures					
After skin contact	Immediately wash with water and soap.				
After eye contact	Immediately wash with flowing water.				
After inhalation	Supply fresh air.				
After ingestion	If symptoms persist, consult doctor.				
5. Fire-fighting measures					
Extinguishing media	Use a fire fighting foam preferably.				
Special exposure hazards in case of fire	Avoid to use water in a closed place.				
Hazardous combustion products	May release CO and CO ₂ in the event of a fire				
Special protective equipment required for fire fighters	Self contained breathing apparatus.				
6. Accidental release (spill measures)					
Personal precautions	Work with a mask against inhalation of dust if it is powdered carbon and wear plastic or rubber gloves if the carbon is spattered.				
Protective measures for environment	Avoid contact between spattered carbon and water. No throw into sewerage system, pipes, waterstreaming and ground water.				
Methods for cleaning spillage	Draw up or scoop up for recovery and destruction of spattered carbon. Draw up or scoop up for recovery and packaging of clean carbon.				
7. Handling and storage					
Handling	Wear of Respiratory Protective Equipment (RPE) is recommended. Avoid dispersal of dust into the air.				
Storage	Store and keep away from chemical products (solvents and strong oxidising agents): absorption risk by them to carbon. Conform to the relevant current regulations on storage in big volumes.				
		ERLAB INC. 388 Newburyport Turnpike Rowley, MA 01969 / USA Tel: +1 (978) 948-2216 / Fax: +1 (978) 948-3354 E-mail: gftsales@erlab.com / www.greenfumehood.com		www.erlab.com	

Non contractual document. erlab® Inc. reserves the right to modify this document without prior notice - V0.1-06.0

Chapter 6: Maintaining the Protector Filtered Hood

 <p>Greenfumehood[®] TECHNOLOGIES A Global Solution For Green Buildings.</p>	<h2>Neutrodine[®]</h2> <h3>filtration technology</h3>	<p><i>Safety Data Sheet</i> <i>According to directive</i> <i>91/155/EC</i></p>
8. Exposure controls/personal protection		
Complementary indications for engineering controls	Protect the electrical equipment against explosions. Local exhaust ventilation is recommended where there is a need to remove dust from the workers breathing zone.	
General measures for hygiene and protection	Do not respire dust, have a good hygiene	
Individual protective equipment	Respiratory Protective Equipment (RPE). Goggles and protective clothing if carbon is spattered.	
9. Physical and chemical properties (typical)		
Appearance	Granules	
Odour	None.	
Colour	Black.	
Molecular weight	12.01 g/Mol	
Density	400 to 600 kg/m ³	
pH	5 to 8	
10. Stability and reactivity		
Stability	Stable, but impregnant soluble in water.	
Conditions to avoid	High temperature.	
Materials to avoid	Solvents and strong oxidising agents.	
Hazardous decomposition products	CO and CO ₂ emanations.	
11. Toxicological information		
Chemical name This material is non-toxic	Carbon.	
12. Ecological information		
Mobility	Dust in the air.	
Ecotoxicity	No specific effects on environment.	
	No throw into natural environment in case of environment modification.	
	Insoluble in aqueous environment, the product is separable by filtration or sedimentation.	
13. Disposal considerations		
Waste activated carbon	To conform to the relevant current regulations.	
Spattered packing	To conform to the relevant current regulations.	
14. Transport information		
Proper shipping name	Carbon (not DOT regulated)	
Hazard class	Not applicable	
UN number	Not applicable	
15. Regulatory information		
None	Carbon (not DOT regulated)	
16. Other information		
<p>This Safety Data Sheet is prepared from the best knowledge available: no responsibility is accepted that the information is sufficient or correct in all cases.</p> <p>The data contained in this Safety Data Sheet has been supplied for the purpose of protecting the health and safety of industrial and commercial users who are deemed capable of understanding and acting on the information provided.</p> <p>This product is recommended for use in air filtration.</p> <p>In addition, users have to pay attention to the possible hazards incurred by the product for other applications than the ones prescribed.</p>		
	<p>ERLAB INC. 388 Newburyport Turnpike Rowley, MA 01969 / USA Tel: +1 (978) 948-2216 / Fax: +1 (978) 948-3354 E-mail: gfhsales@erlab.com / www.greenfumehood.com</p>	<p>www.erlab.com</p>

Non contractual document. erlab® Inc. reserves the right to modify this document without prior notice - V01-0610

Partial Filter Replacement Procedure

This procedure will be needed to perform a partial replacement. When replacing the saturated primary filters, rotate the secondary down as the new primary and place the new filters on top of the fans at the secondary level.

We recommend the following:

- We recommend that you follow all your existing lab safety protocols as they apply to this procedure.
- That you have another person to assist you if possible.
- Refer to the GFH tool list to be sure to have any needed tools on hand.
- Please read through it thoroughly before you attempt it.

Items Needed:

- 6ft ladder
- Marker & or white out
- Any OEM partner tools to remove front panels
- Administrator card

Overview of Procedure

1. Remove front panels to expose the filters.
2. Identify your Model, either a M1 (3'), M2 (4'), M3 (5'), M4 (6') or M5 (8').
3. Mark your Primary filters "used" and secondary filters "primary."
4. Turn off the hood.
5. Select "filters" under Admin menu of control module.
6. Select "partial replacement" in the filters menu.
7. Take off secondary filters and unplug fans.
8. Remove the fans.
9. Remove your old primary filters that you marked "used."
10. Scan out old primary filters marked "used."
11. Scan in your new filters.
12. Install your filters that you marked "primary" earlier as your primary filters.
13. Place fans back on top of the primary filters.
14. Connect the fan wires and tubing.
15. Recheck all your connections.
16. Enter your filter lifetime as stated in your LP report or you can enter the two year max which is 730 days.
17. Turn on and test hood.
18. Install your new filters on top of your fans at your secondary level.

Chapter 6: Maintaining the Protector Filtered Hood

Step 1 – Remove front panels

Remove Protector Hood front panel or panels to expose the technology and filter media.

Step 2 – Identify your model

Determine your model number which is a M1 (3'), M2 (4'), M3 (5'), M4 (6'), or M5 (8'). A decal on the front of the control module has your model on it. These numbers are based on how many stacks of technology that you have on top of your hood from left to right and the hood width.

- Look at your hood and count the stacks of technology from left to right
- You will have 2, 3, 4, or 5 stacks for 4', 5', 6', and 8' filtered hoods.
- Match that number to M1, M2, M3, M4, or M5.
- This information will help you follow this procedure when it applies to your model M1, M2, M3, M4, M5.

Example of a M2 (4') below, having two stacks

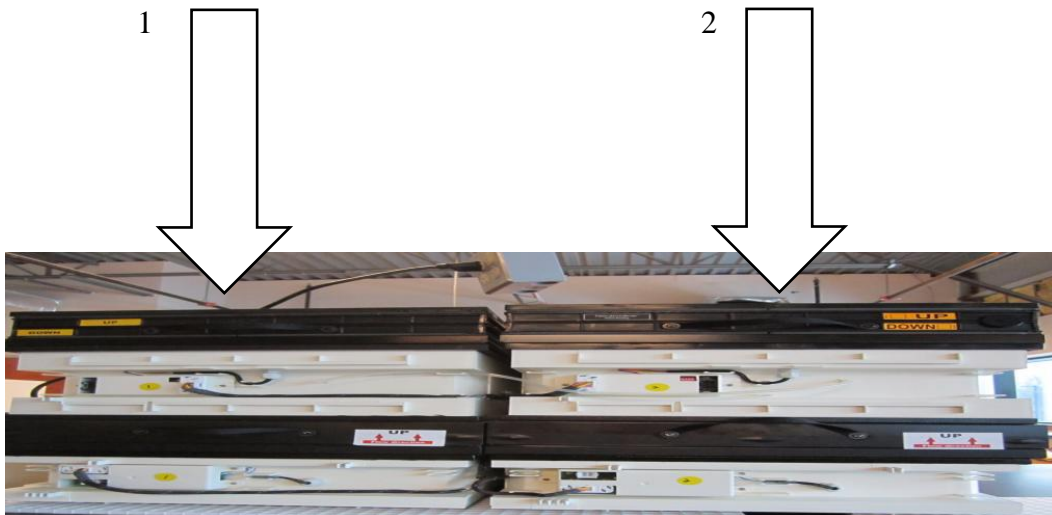

Step 3 – Mark your Primary and Secondary Filters

Mark your primary filters (your primary filters are the lowest set of filters from left to right facing the hood and they are in between the lights and the fans). Write the word “used” on the primary filter with a marker.

Mark your secondary filters (your secondary filters are the top most set of filters from left to right facing the hood). Write “primary” on each secondary filter.

Step 4 – Turn off the hood

Press the fan icon once on the control module to turn it off. It will count down 30 seconds and then power down.

Note Leaving the fan on will not allow you to see the filter menu to do a partial replacement. It will be dashed out.

Step 5 – Select “filters” in the control module

Use your Administrator card and place it into the card reader.

You will now see:

>Hood Status menu
Administration menu

Move down to the **Administrator** menu and press **OK** to select it.

You will now see:

- Language
- Date and Time
- Filters
- Alarms and Sensors
- Users and Management
- Network Parameters
- Erase History
- Ventilation

Arrow down to **Filters** and press **OK** to select it

Note If at any time during this procedure the screen goes black press **OK** to illuminate it.***

Chapter 6: Maintaining the Protector Filtered Hood

Step 6 – Select “Partial replacement” in the control module

You will now see: **Filter List**
 Total Replacement
 Partial Replacement

Arrow down to **Partial Replacement** and press **OK** to select it.

This procedure is broken up into 9 steps. Continue to follow these steps.

You will now see: **[Partial Replacement]**
 Step #1
 Remove your ID

Remove the **Administrator** card from the card holder and then press **OK**.

Step 7 – Take off secondary filters and unplug fans

You will now see: **[Partial Replacement]**
 Step #2
 Unplug Fans

Note at this point you should have already marked your primary and your secondary filters. If not, mark the primary filters with the word “used” and your secondary ones with “primary.”

Now take off your secondary filters, which are on the top row facing the hood from left to right.

Take them down one by one. To remove a filter, lift up on the front then turn your hand left then right to break the back edge free from the fan. Now you should have the back of the filter free and pull it towards you until you are able to grab it with your other hand.

Once you have it with both hands, either hand it to someone else standing nearby or be very careful and step down the ladder. Place them in a stack on the floor out of the way.

Very important Your fans have specific locations. They will need to be reinstalled in the same locations from which they were removed.

Facing the hood from left to right is your row of fans. The left most fan is fan #1, then to the right of that fan #2, then 3, 4, 5 based on how many stacks of technology you have (M1, M2, M3, M4, or M5).

To ensure proper reinstallation, mark your fans with a sticker, or a marker. Place a 1, 2, 3, 4, or 5 on each fan so that you know which position to return it to.



CAUTION: Do not contact fan wheel while still in motion.

PRUDENCE: Ne pas contacter roue du ventilateur tout en en mouvement.

Now follow through the procedure with your specific model (M1, M2, M3, M4, or M5). Once you have all of your fans disconnected continue to the next step.

(M1, M2, M3, M4, M5) Fan #1

On fan #1, on the left side of the fan box, unplug the power supply that comes from the control module.



Leave the other wire to the right that extends to fan #2 connected to fan #1. Unplug the other end from fan #2.

Look for the clear air tube that is coming up from the control module and remove it from the “T” connector. Pull the other side of the “T” off fan #1.

Fan #1 should now be free.

(M2) Fan #2

Move your ladder to the right so you will be in front of fan #2. Disconnect the air tube that is on fan #2 and place the air tube on the control module.

Fan #2 should now be free. Proceed to the next step.

(M3, M4, M5) Fan #2

Move your ladder to the right so you will be in front of fan #2. Leave the wire to the right that extends to fan #3 connected to fan #2. Unplug the other end from fan #3.

Disconnect the air tube from the “T” that went to fan #1 and place the tubing on top of the control module. Now pull the air tube off fan #2.

Fan #2 should now be free.

Chapter 6: Maintaining the Protector Filtered Hood

(M3) Fan #3

Move your ladder to the right so you will be in front of fan #3. Disconnect the air tube that is on fan #3 and place the air tube on the control module.

Fan #3 should now be free. Proceed to the next step.

(M4, M5) Fan #3

Move your ladder to the right so you will be in front of fan #3. Leave the wire to the right that extends to fan #4 connected to fan #3. Unplug the other end from fan #4.

Disconnect the air tube from the “T” that went to fan #2 and place the tube on top of the control module. Now pull the air tube off fan #3.

Fan #3 should now be free.

(M4) Fan #4

Move your ladder to the right so you will be in front of fan #4. Disconnect the air tube that is on fan #4 and place the air tube on the control module.

Fan #4 should now be free. Proceed to the next step

(M5) Fan #4

Move your ladder to the right so you will be in front of fan #4. Leave the wire to the right that extends to fan #5 connected to fan #4. Unplug the other end from fan #5.

Disconnect the air tube from the “T” that went to fan #3 and place the tube on top of the control module. Now pull the air tube off fan #4.

Fan #4 should now be free.

(M5) Fan #5

Move your ladder to the right so you will be in front of fan #5. Disconnect the air tube that is on fan #5 and place the air tube on the control module.

Fan #5 should now be free. Proceed to the next step.

Step 8 – Remove the fans

*** Be very careful not to chip the plastic sealing edge of the fan boxes.***

Ideally, store them so that the back edge down is on the floor with the circuit board facing up. *** Place them out of the way.***



Take them down one by one. For each, lift up on the front and then turn your hand left then right to break the back edge free from the filter. Once you have the back of the fan free, you can pull it towards you until you are able to grab it with your other hand.

Once you have it with both hands either hand it to someone else standing nearby or be very careful and step down the ladder.

*** Be very careful not to chip the plastic sealing edge of the fan boxes.***

Now as you face the hood looking left to right, you should see your primary filters marked “used” and your lights below.

Now go back to the control module press “OK” to illuminate the screen. Then press “OK” again to go to the next step.

Step 9 – Remove your old primary filters that you marked “used”

You should now see: **[Partial Replacement]**
Step #3
Remove Old Filters

Take down your old primary filters and put in a stack near the hood (as you will need to scan them out later).

Take them down one by one. For each filter, lift up on the front and then turn your hand left then right to break the back edge free from the filter. Once you have the back of the filter free, pull it towards you until you are able to grab it with your other hand.

Once you have it with both hands either hand it to someone else standing nearby or be very careful and step down the ladder.

At this time, it is strongly recommended that you inspect your lights and pre-filters since this is a convenient time to replace your pre-filters and swap out any bad or suspect bulbs.

Chapter 6: Maintaining the Protector Filtered Hood

Once you are done with your inspection press “OK” to illuminate the screen. Then press “OK” again to go to the next step.

Step 10 – Scan out old primary filters marked “used”

You will see: **[Partial Replacement]**
Step #4
Record Old Filter Tags

Below is what the screen display means based on your specific model M1, M2, M3, M4, or M5

M1 = 1 primary filter & 1 secondary filter = 2 total Neutrodine filters = **0/2**
 M2 = 2 primary filters & 2 secondary filters = 4 total Neutrodine filters = **0/4**
 M3 = 3 primary filters & 3 secondary filters = 6 total Neutrodine filters = **0/6**
 M4 = 4 primary filters & 4 secondary filters = 8 total Neutrodine filters = **0/8**
 M5 = 5 primary filters & 5 secondary filters = 10 total Neutrodine filters = **0/10**

Scan out your old primary filters one at a time.

Scan out your old primary filters only.

To scan out, place your ladder in front of the control module so that you have easy access to the RFID “card reader.”

The RFID tags are the black round discs that are on the front of all filters.

One by one, hold the filters in front of the control module to scan out the RFID tag on each primary filter. Listen for the beep when you scan them out.

Once you have scanned them all out you should see **0/_** where the **0** will be the total number of primary filters that you have and the **_** will signify all the Neutrodine filters that you have based on the hood size (M2, M3, M4, M4).

Example: For a M3 you would see **3/6** a three being your primary filters that were scanned out and the six being your total Neutrodine filters.

At this point check to see that the left number reflects the number of primary filters that you have either a M2, M3, M4, M5.

If the number is not correct, rescan out the old primary filters as one must have been missed.

Once it is correct press “OK” to go to the next screen.

Step 11 – Scan in your new filters

You should now see: **[Partial Replacement]**
Step #5
Record New Filter Tags

Unpack all your new filters for the hood you are working on only and save the plastic bags for covering the old primary filters later on.

Below is what the screen display means based on your specific model M1, M2, M3, M4, or M5

M1 = 1 primary + 1 secondary filter = 2 total & 1 opt. Hepa filters = 3 total = **0/3**
 M2 = 2 primary + 2 secondary filters = 4 total & 2 opt. Hepa filters = 6 total = **0/6**
 M3 = 3 primary + 3 secondary filters = 6 total & 3 opt. Hepa filters = 9 total = **0/9**
 M4 = 4 primary + 4 secondary filters = 8 total & 4 opt. Hepa filters = 12 total = **0/12**
 M5 = 5 primary + 5 secondary filters = 10 total & 5 opt. Hepa filters = 15 total = **0/15**

***Do not be confused. The **_** reflects your total filters plus the option of a HEPA filter layer.

For example a M3 would be **0/9**; where the **9** reflects all of your filters plus an optional layer of HEPA filters.

The left number again will change as each filter is scanned in.

To scan in, place your ladder in front of the control module so that you have easy access to the RFID “card reader.”

The RFID tags are the black round discs that are on the front of all filters.

One by one hold the filters (for that hood only) in front of the control module to scan in the RFID tag on each new filter. Listen for the beep when you scan them in.

Once you verified that they are all scanned in based on your hood size (M2, M3, M4, M5), you may press **OK** to continue.

Step 12 – Install your filters that you marked “Primary”

Install your existing secondary filters that you marked “Primary” as your new primary filters.

You will now see: **[Partial Replacement]**
Step #6
Install new filters

Chapter 6: Maintaining the Protector Filtered Hood

It is a rotating system. Your existing secondary filters (that you marked “primary” earlier) are the first to go back on your lights as your primary filters. Your new ones will be your new secondary filters.

Go back to your stack of secondary filters that you marked “primary” earlier. Work from left to right, place the filters one at a time on top of your lights.

Make sure that the words “Up” and “Down” face the front of the hood and the position is correct. Also check that they are seated properly on the top edge of the light box on all sides.

Press “OK” to continue.

Step 13 – Put the fans back on the primary filters in proper order

You should now see: **[Partial Replacement]**
Step #7
Plug fans back

Retrieve fan #1 that you labeled and set aside earlier.

Be careful not to chip the edge of the fan box.

(M1, M2, M3, M4, M5) Place fan #1 on top of the leftmost primary filter. Place the back edge down first on the top of the filter and gently slide it back into position.

Make sure that it is seated on all sides of the groove of the filter.

Ensure the fan is in the upright position with the circuit board to the front as shown below.

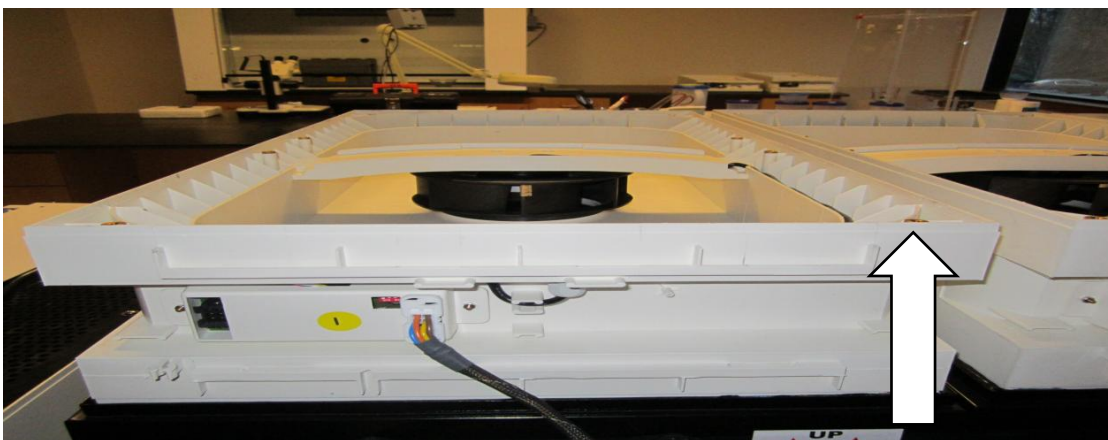

(M1, M2, M3, M4, M5) Now move your ladder to the right and retrieve fan #2 that you labeled. Place fan #2 on top of the primary filter to the right of fan #1 that you just installed. Place the back edge down first on the top of the filter and gently slide it back into position.

Make sure that it is seated on all sides of the groove of the filter.

(M3, M4, M5) Now move your ladder to the right and retrieve fan #3 that you labeled earlier. Place fan #3 on top of the primary filter to the right of fan #2 that you just installed. Place the back edge down first on the top of the filter and gently slide it back into position.

Make sure that it is seated on all sides of the groove of the filter.

(M4, M5) Now move your ladder to the right and retrieve fan #4 that you labeled earlier. Place fan #4 on top of the primary filter to the right of fan #3 that you just installed. Place the back edge down first on the top of the filter and gently slide it back into position.

Make sure that it is seated on all sides of the groove of the filter.

(M5) Now move your ladder to the right and retrieve fan #5 that you labeled earlier. Place fan #5 on top of the primary filter to the right of fan #4 that you just installed. Place the back edge down first on the top of the filter and gently slide it back into position.

Make sure that it is seated on all sides of the groove of the filter.

Step 14 – Connect your fan wires and air tube

(M1, M2, M3, M4, M5) Air tube

Retrieve one of your air tubes that you placed on the top of the control module. Place the tube in your hand with the “T” to your left and the length of tube to your right. Now slide the end of the “T” onto fan #1 except for M1. Make sure that it is on all the way to the fan box. Run the other end over to fan #2.

(M1, M2, M3, M4, M5) Wire

You should still have the wire connector plugged into the right side of fan #1 except for M1. Take the other side and plug it into the left side of fan #2. Slide the wire under the plastic tabs that are on the front of each fan box. The goal here is to keep it neat and tight so it does not interfere with the front panel.

(M2) Air tube

Move your ladder to the right in front of fan #2. Slide the air tube behind the black fan wire where it goes up into the fan box. Connect the end of the tube directly to the fan box.

(M3, M4, M5) Air tube

Retrieve one of your air tubes that you placed on the top of the control module. Place the tube in your hand with the “T” to your left and the length of tube to your right. Now slide the end of the “T” onto fan #2. Make sure that it is on all the way to the fan box. Now connect the tube from fan #1 to the “T” on fan #2. Run the other end over to fan #3.

(M3, M4, M5) Wire

You should still have the wire connector plugged into the right side of fan #2. Take the other side and plug it into the left side of fan #3. Slide the front of the

Chapter 6: Maintaining the Protector Filtered Hood

wire under the plastic tabs that are on the front of each fan box. The goal here is to keep it neat and tight so it does not interfere with the front panel.

(M3) Air tube

Retrieve your ladder to the right in front of fan #3. Slide the air tube behind the black fan wire where it goes up into the fan box. Connect the end of the tube directly to the fan box.

(M4, M5) Air tube

Grab one of your air tubes that you put on the top of the control module. Place the tube in your hand with the “T” to your left and the length of tube to your right. Now slide the end of the “T” onto fan #3. Make sure that it is on all the way to the fan box. Now connect the tube from fan #2 to the “T” on fan #3. Run the other end over to fan #4.

(M4, M5) Wire

You should still have the wire connector plugged into the right side of fan #3. Take the other side and plug it into the left side of fan #4. Slide the wire under the plastic tabs that are on the front of each fan box. The goal here is to keep it neat and tight so it does not interfere with the front panel.

(M4) Air tube

Move your ladder to the right in front of fan #4. Slide the air tube behind the black fan wire where it goes up into the fan box. Connect the end of the tube directly to the fan box.

(M5) Air tube

Retrieve your last air tube that you placed on the top of the control module. Place the tube in your hand with the “T” to your left and the length of tube to your right. Now slide the end of “T” onto fan #4. Make sure that it is on all the way to the fan box. Now connect the tube from fan #3 to the “T” on fan #4. Run the other end over to fan #5.

(M5) Wire

You should still have the wire connector plugged into the right side of fan #4. Take the other side and plug it into the left side of fan #5. Slide the wire under the plastic tabs that are on the front of each fan box. The goal here is to keep it neat and tight so it does not interfere with the front panel.

(M5) Air tube

Move your ladder to the right in front of fan #5. Slide the air tube behind the black fan wire where it goes up into the fan box. Connect the end of the tube directly to the fan box.

You should now have:

- All the air tubes connected to each fan box from one to the next from left to right

- All the wire connections connected to each fan box from one to the next from left to right.

Take your time to look it over and verify that all the connections are made properly. Once you verify they are correct, move your ladder to the left and connect the control module wires into the left side of fan #1. Also connect the air tube coming from the control module back to the “T” on fan #1.

Step 15 – Recheck your connections

Check your work to ensure all connections are correct and fan placement is correct.

You should have all of your fans installed based on your hood size, M2, M3, M4, M5. Move your ladder and start at the left again, check your fans to make sure that they are in their correct position based on the number you labeled earlier.

Example of a M3



Return to the control module and press “OK” to illuminate the screen. Then press “OK” again to go to the next step.

You will see: **[Partial Replacement]**
Step #8
Reinsert your id card

Put your administrator card back in the holder and press “OK” to continue.

Step 16 – Enter your filter lifetime

You will now see: **[Partial Replacement]**
Step #9
Enter filter lifetime

365 D
5 Min
730 Max

Put in the days as stated in your LP report or 730 for the 2 year maximum. Use the arrow keys to enter the correct #.

Chapter 6: Maintaining the Protector Filtered Hood

Press “**OK**” to continue.

Press “**X**” to return to the previous menu.

Press “**X**” again and you should be back to the main menu.

You should see: **(Access Granted)**

>Hood Status menu
Administration menu

Step 17 – Test the hood

Now turn on your fans and lights. If everything is connected correctly, it should operate properly. Once you determine the fans and lights are operational, turn it off. Wait 30 seconds for it to completely shut down.

If the control has no errors proceed to the next step.

If the control panel does have errors

- Check all your connections again (make sure the wires are securely in their slots).
- Make sure you have your fans in the correct position from left to right 1,2,3,4, or 5.
- Check the “Dip” switches on the front of each fan.
Based on their position from left to right:

Fan #1 should be **On, Off, Off, Off = Down, Up, Up, Up**

Fan #2 should be **On, Off, Off, On = Down, Up, Up, Down**

Fan #3 should be **On, Off, On, Off = Down, Up, Down, Up**

Fan #4 should be **On, Off, On, On = Down, Up, Down, Down**

Fan #5 should be **On, On, Off, Off = Down, Down, Up, Up**

If you need to adjust the **DIP** switch, you may use a very small regular screw driver or even a pencil. Make your adjustments by putting light pressure on the **DIP** switch to either move it up (**off**) or down (**on**).

Reboot the hood by sliding your finger nail under the black fuse cartridge located on the left side of the controller, slide it out to break the connection, wait 1 min and plug it back in.

If you still have a problem, write down what the control module screen displays and call Labconco Product Service. Do not attempt another hood until you fix the issue.

Step 18 – Install your new filters

Move your ladder back to the left and place your new filters on top of the fan boxes as your new secondary filters.

Example of a M3 below

Now place the front panel or panels back on the hood that you removed earlier in step 1.

Congratulations! You have completed the installation.

Reconfiguration Process

This procedure is used the first time a technician installs and sets up the Protector Filtered Hood and is listed in Chapter 3. The Reconfiguration Process is also needed to resolve a hardware mismatch 9A alarm. Additionally, many maintenance steps that involve component replacement include the Reconfiguration Process. Please refer to “Reconfiguration Process” in Chapter 3.

Light and/or Circuit Board Replacement



**Green Fume Hood
TECHNOLOGIES**
A Global Solution For Green Buildings



**Lighting module
Troubleshooting**

For Green Fume Hood® Technologies



Model: M2 - M3 - M4 and M5



Replacing a printed circuit board



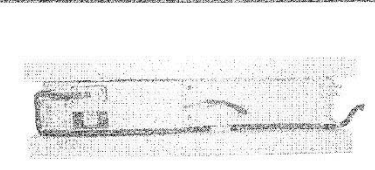
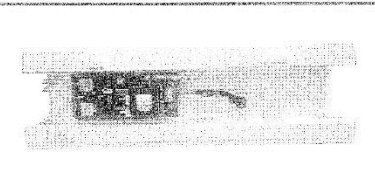
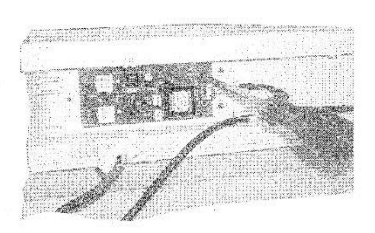
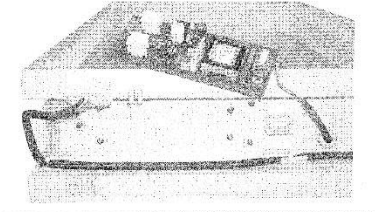
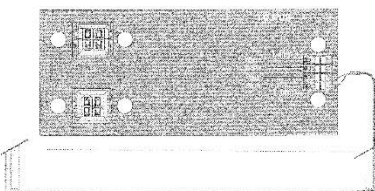

You are strongly advised to wear the following protective equipment during these operations: glasses, lab coat and gloves.

- 1 - Switch off the device.**
- 2 - Remove the front panel from the filtration column with the faulty lighting module.**
- 3 - The operation to replace the lighting module printed circuit board does not require the filtration column to be dismantled.**
- 4 - Disconnect the connection cables from the printed circuit board.**
- 5 - Remove the protective box from the printed circuit board using a 5.5 bit driver.**
- 6 - Remove the printed circuit board using a 5.5 bit driver.**
- 7 - Disconnect the four wires from the spring terminal block with the point of a screw driver or by pressing on it with a finger.**
- 8 - Connect the replacement printed circuit board, ensuring the colors of the wires correspond to the markings on the printed circuit board (Lamp + = White, Lamp - = Blue).**
- 9 - Attach the printed circuit using the 4 M3 nuts and a 5.5 bit driver.**
- 10 - Before attaching the protection box and reinstalling the front panel we advise you to check that the lighting module is working properly.**
- 11 - Reconnect the printed circuit board connection cables. Switch on the device, insert your authorized access card then press the lighting ON-OFF button.**
- 12 - Reinstall the front panel.**

115





**Green Fume Hood
TECHNOLOGIES**
A Global Solution For Green Buildings

**Lighting module
Troubleshooting**
For Green Fume Hood® Technologies
Model: M2 - M3 - M4 and M5



Replacing a lamp

You are strongly advised to wear the following protective equipment during these operations: glasses, hard hat and gloves.

- 1 - Switch off the device.
- 2 - Remove the front panel from the filtration column with the faulty lighting module.
- 3 - Replacing the 2G11 18W fluorescent tube from the lighting module does not require the system to be reconfigured.
- 4 - Remove the security filter module.
- 5 - Disconnect the connection cables from the fan module. Disconnect the sampling tube. Remove the fan module.
- 6 - Remove the main filter module.
- 7 - Disconnect the connection cables from the lighting module. Remove the lighting module and lay it on a table.
- 8 - Remove the prefilter **A**. Caution. You must remove it without bending it.
- 9 - Pull the lamp tube and holder **B** gently upwards. Do not force it, the connection cable is located in the lamp holder end piece **C**. Then free the rear end piece holding the lamp **D**.
- 10 - Reassemble the unit by performing the operations described above in reverse order.

Caution: Reassemble the unit by performing the operations described above in reverse

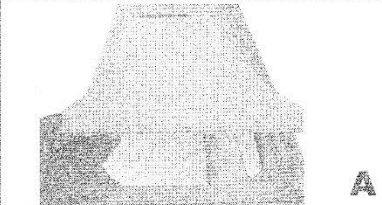

A

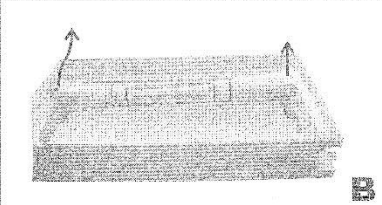

B

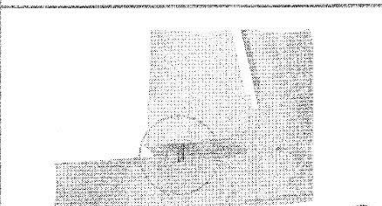

C

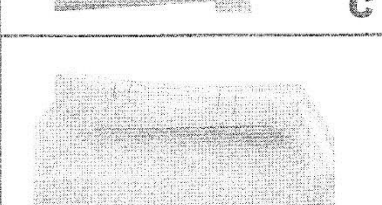

D

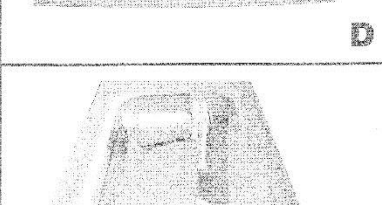

E

116

Fan and/or Circuit Board Replacement



**Green Fume Hood
TECHNOLOGIES**
A Global Solution For Green Facilities

**Fan module
Troubleshooting**
For Green Fume Hood® Technologies
Model: M2 - M3 - M4 and M5



Replacing a Printed Circuit Board



You are strongly advised to wear the following protective equipment during these operations: glasses, lab coat and gloves.

- 1 - Switch off the device.
- 2 - Remove the front panels from the faulty filtration columns.
- 3 - This operation requires the filtration columns to be dismantled in order to reconfigure the device.
- 4 - Disconnect the connection cables between the printed circuit boards for each fan module, the connection cable between the control module and the fan module F1. Disconnect the sampling tubes between the fan modules. Remove the filter modules, the fan modules and the security filter modules
- 5 - Place the fan module with the faulty printed circuit board on a table.
- 6 - Remove the protective box from the printed circuit board **A** using a 5.5 bit driver.
- 7 - Remove the printed circuit board **B** and **C**.
- 8 - Disconnect the four wires from the spring terminal block **D** with the point of a screw driver or by pressing on it with a finger.
- 9 - Connect the replacement printed circuit board, ensuring the colors of the wires correspond to the markings on the circuit (R=Red, B=Blue, W=White, Y=Yellow).
- 10 - The label **E** stuck on the circuit protection box gives the position occupied by the fan box. With the help of the label and a small screw driver, set the four micro-switches to one of the two positions OFF or ON.
- 11 - Follow the procedures described in page 24 to reconfigure the device.

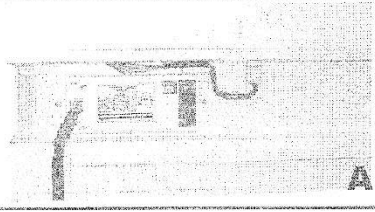

A

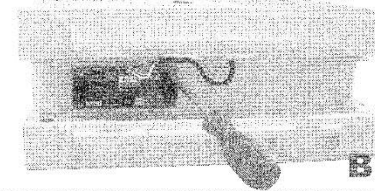

B

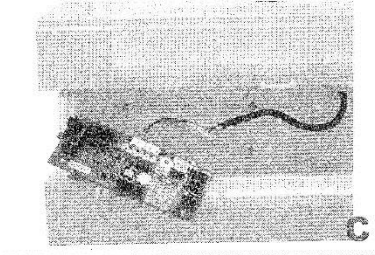

C





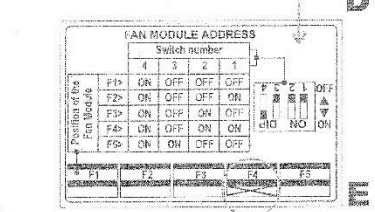



D

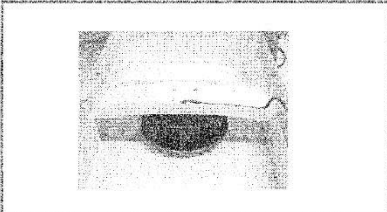

E

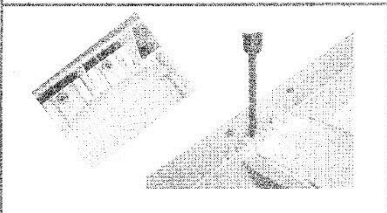
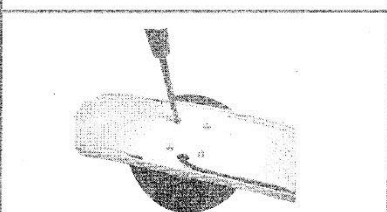
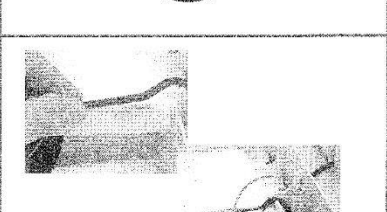
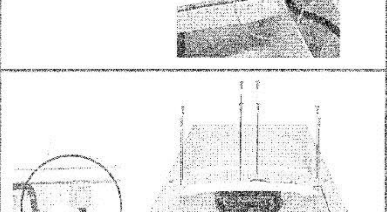
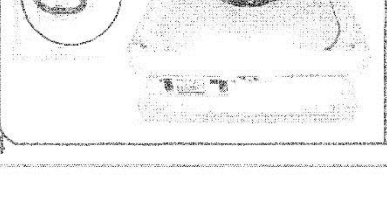
		FAN MODULE ADDRESS				Switch number			
		1	2	3	4	1	2	3	4
Position of the Fan Module	F1*	ON	OFF	OFF	OFF	OFF	OFF	OFF	OFF
	F2*	ON	OFF	OFF	OFF	ON	OFF	OFF	OFF
	F3*	ON	ON	OFF	OFF	OFF	OFF	OFF	OFF
	F4*	ON	ON	ON	OFF	OFF	OFF	OFF	OFF

	Fan module Troubleshooting For Green Fume Hood® Technologies Model: M2 - M3 - M4 and M5	
Remplacing a fan		
		
	<p>You are strongly advised to wear the following protective equipment during these operations: glasses, lab coat and gloves.</p>	
	<p>1 - Switch off the device.</p>	
	<p>2 - Remove the front face from the faulty filtration column.</p>	
	<p>3 - Remove the security filter module.</p>	
	<p>4 - Disconnect the connection cables from the printed circuit. Disconnect the sampling tube. Remove the fan module. Leave the main filter module and lighting module in place.</p>	
	<p>5 - Place the fan module containing the fan to be replaced on a table.</p>	
	<p>6 - Remove the two M3 fastening screws from the printed circuit protection box using a 5.5 bit driver.</p>	
	<p>7 - Remove the four M3 fastening screws from the printed circuit using a 5.5 bit driver.</p>	
	<p>8 - Disconnect the four fan wires from the spring terminal block with the point of a screw driver or by pressing on it with a finger.</p>	
	<p>9 - Loosen the cable gland, pull on the fan connection cable.</p>	
	<p>10 - Remove the cable from its guide as far as the fan, remove the four fastening screws from the fan bridge using a cross-tip screwdriver.</p>	
	<p>11 - Remove the fan bridge and lay it on the table. Remove the four fastening screws from the fan using a cross-tip screwdriver.</p>	
	<p>12 - Attach the new fan on its bridge and perform the operations above in reverse order.</p>	
	<p>13 - Caution: before running the fan cable through the cable gland, ensure the cable runs correctly in the groove provided.</p>	
	<p>14 - Reassemble the unit by performing the operations described above in reverse order.</p>	

Fan Box Replacement

Overview

1. Remove front panels to expose the technology.
2. Identify your failed fan box, 1, 2, 3, 4 or 5.
3. Write down all parameters under “Hood status.”
4. Turn off hood.
5. Remove failed fan box.
6. Put in new fan box.
7. Follow the Reconfiguration process.

Step 1 – Remove front panels

Using your ladder, remove the panel or panels so you can access the RFID filter tags later in this procedure.

Step 2 – Identify your failed fan box

As you stand in front of the hood looking left to right, the leftmost stack of technology is fan #1, to the right of that is fan #2, and to the right of that fan #3, 4, or 5, based on the size of your hood (M1, M2, M3, M4, or M5).

The micro switches are set accordingly based on their position, 1,2,3,4 or 5. So identify what number the failed fan box is and make note of the **micro** switch settings.

Make sure that the **micro** switch setting on the new fan box is set to match the failed one’s settings that you are removing.

Step 3 – Write down parameters under “Hood Status”

Using a maintenance card, place it in the card reader and press **“Ok”** on the **“Hood status”** menu to open it.

It may be necessary to press **“Ok”** again to open the **“Hood Status”** menu again.

Then arrow up or down to record the following on paper:

DHCP: X

IP: XXX.XXX.XXX.XXX

MSK: XXX.XXX.XXX.XXX

GW: XXX.XXX.XXX.XXX

(You will need this information only if you have gGuard installed.)

If DHCP is **yes** then you have a dynamic IP if **no** then you have a static IP which you must reenter completely.

Elapsed Time

Filter X D (this is the # of days since install)

Fans

Set point Dflt. XXXX rpm

Set point XXXX rpm

Semicon S. trig value (example 3500)

Trig. X

Delay X

Sash

Which type (example. normal polarity)

Trig X %

Now press “X” to return to the previous menu.”

Step 4 – Turn off the hood

Press the fan icon to turn off the controller waiting the 30 seconds to completely shut down. Also if the light is on, turn it off as well.

Step 5 – Remove failed fan box

Take off the secondary filter that is directly above the fan you are replacing. Once you have it removed unplug the following:

- The left fan power supply wire
- Air sampling tube
- The right fan power supply wire to the next fan (if applicable)

Again make note of the **micro** switch settings of that fan.



CAUTION: Do not contact fan wheel while still in motion.

PRUDENCE: Ne pas contacter roue du ventilateur tout en en mouvement.

Chapter 6: Maintaining the Protector Filtered Hood

Step 6 – Put in new fan box

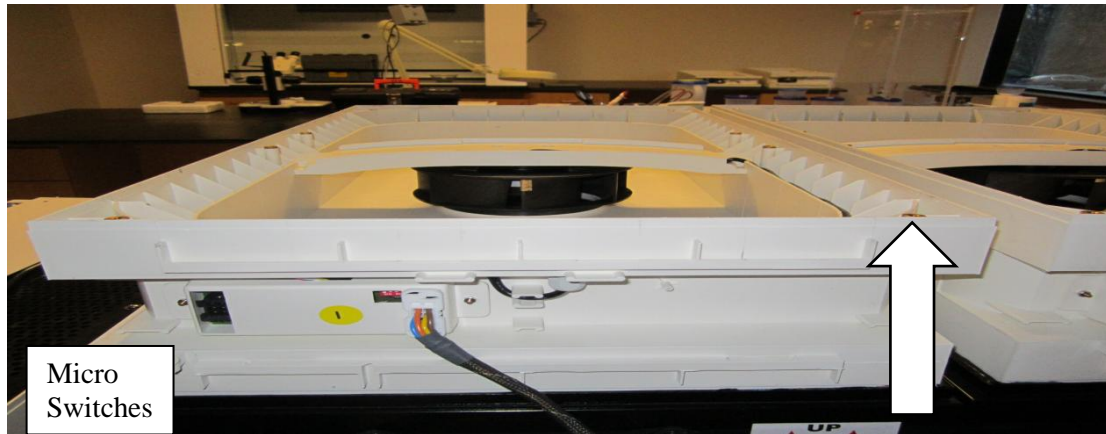

Place new fan box up on the primary filter making sure that the fan is up and that it is properly seated on to the primary filter.

Place the secondary filter on top of the fan box and make sure that it is properly seated onto the edges of the fan box.

Now make your connections:

- The left fan power supply wire
- Air sampling tube
- The right fan power supply wire to the next fan (if applicable)

Make sure the micro switch settings of the new fan are the same as that of the old fan.

- Check the micro switches on the front of the replacement fan. Based on their position from left to right:

Fan #1 should be **On, Off, Off, Off = Down, Up, Up, Up**

Fan #2 should be **On, Off, Off, On = Down, Up, Up, Down**

Fan #3 should be **On, Off, On, Off = Down, Up, Down, Up**

Fan #4 should be **On, Off, On, On = Down, Up, Down, Down**

Fan #5 should be **On, On, Off, Off = Down, Down, Up, Up**

If you need to adjust the **micro** switch, you may use a very small slotted screw driver or even a pencil. Make your adjustments by putting light pressure on the **micro** switch to either move it up (**off**) or down (**on**).

Step 7 – Follow the Reconfiguration Process

Now follow the Reconfiguration Process at step #3. If after you have completed the process you are still having issues please contact Labconco Product Service.

Electro (Acid) Sensor Replacement (every 2 years)

We recommend the following:

- We recommend that you follow all your existing lab safety protocols as they apply to this procedure.
- That you have another person to assist you when possible.
- Please thoroughly read through before attempting it.

Items needed:

- 6ft ladder
- Piece of cardboard
- Maintenance Card
- Small slotted screwdriver and small Phillips screwdriver

Some GFH models have #2 Phillips screws for everything listed below

- Small Phillips Screwdriver
- 4mm Allen wrench (for Control module screws)
- Torx TX20 (back panel screws)
- Torx TX10 (Electro/Acid sensor board)

Overview

1. Write down all parameters under “Hood Status.”
2. Turn off hood.
3. Remove front panel and identify electrical connection whether it is either hardwired or plugged into a receptacle.
4. Disconnect all connections from control module that connects to the technology.
5. Remove control module & electrical cord set if applicable to your set up.
6. Snake all remaining wires that are routed through the superstructure to control module.
7. Remove back panel to control module.
8. Disconnect and remove old sensor.
9. Install new sensor.
10. Attach back panel to control module.
11. Snake all remaining wires that are routed through the superstructure to control module.
12. Connect the electrical cord set to the controller, if applicable to your set up.
13. Attach the control module to the mounting bracket.
14. Connect all remaining wires.
15. Turn power back on.

Chapter 6: Maintaining the Protector Filtered Hood

Step 1 – Write down parameters under “Hood Status”

Using a maintenance card, place it in the card reader and press “Ok” on the “Hood status” menu to open it.

It may be necessary to press “Ok” again to open the “Hood Status” menu.

Then arrow up or down to record the following on paper:

DHCP: X

IP: XXX.XXX.XXX.XXX

MSK: XXX.XXX.XXX.XXX

GW: XXX.XXX.XXX.XXX

(You need this information only if you have gGuard installed.)

If DHCP is **yes** then you have a dynamic IP, if **no** then you have a static IP which you must reenter completely.

Elapsed Time

Filter X D (this is the # of days since install)

Fans

Set point Dflt. XXXX rpm

Set point XXXX rpm

Semicon S. trig value (example 3500)

Trig. X

Delay X

Sash

Which type (example. normal polarity)

Trig X %

Now press “X” to return to the previous menu.”

Step 2 – Turn off the hood

Turn off the hood by pressing the fan icon on the front of the control module. Wait 30 seconds for the hood to completely power down. If the lights are on, press the light icon to turn the lights off as well.

Also turn off all power supplied to the unit after you have powered it down waiting the 30 seconds.

Very important all power supplied to hood must be turned off at the breaker.

Step 3 – Remove front panel & identify electrical connection

The removal of the front panel will expose the technology so you can access the connections that go from the control module up to the technology.

Only identify the electrical connection at this point.

Standing on a ladder, identify the connector to the module.

Step 4 – Disconnect the connections from control module

In order to remove the control module, you must first disconnect the following from the control module to the technology:

- Light supply wire from control module to light #1
- Fan supply wire from control module to fan #1
- Air tube from control module to the “T” on fan #1
- Temp sensor
- Sash sensor

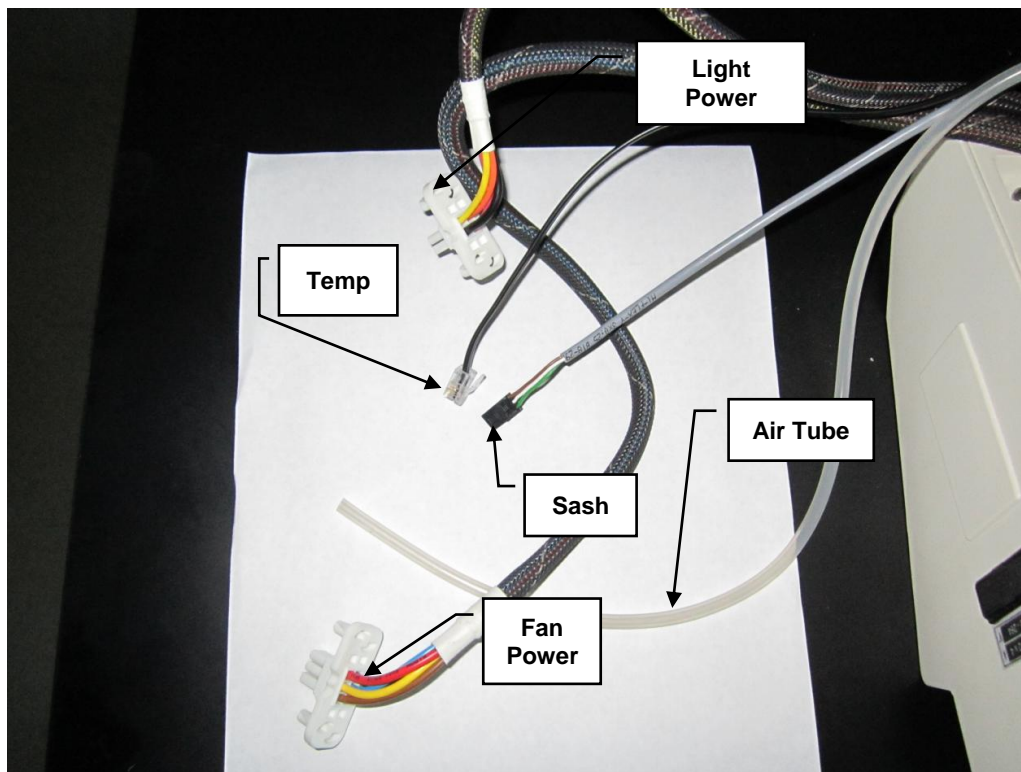

You should now have those connections removed.

Chapter 6: Maintaining the Protector Filtered Hood

Step 5 – Remove control module & electrical cord set

If your application as it relates to step #3 is plugged directly into an outlet on the top of the hood, unplug it at this time.

Standing on a ladder, remove the left screw only on the top of the control module.

Be prepared that the control module will be completely free when you remove the other screw.

Next remove the screw to the right and hold the module up so it does not fall forward.

Now let the control module move forward slightly and then lift it straight up to free it from the lower bracket of the front mounting plate.

Once you have it off the bracket, have your helper hold it, allowing you to be free to remove the final connections:

- Ethernet cable (if applicable)
- Power cord (depending on your application)

Unplug the ethernet connection and remove it from the controller. If your controller is not hardwired into the electrical system and plugged directly into an outlet on the top left side of the hood you may now move on to the next step.

Otherwise if your controller is hardwired directly into your electrical system then you must continue with the rest of this step.

Again at this point make sure all power supplied to the hood controller is turned off at the breaker.

Next, disconnect the quick connect to remove the control module from the inlet power electric cord set.

Step 6 – Snake all remaining wires up through hood

Now snake the wires that you disconnected from step #4 through the hood as needed so that you can completely remove the controller from the super structure.

Once you have the control module free, have your helper place it on a table so that it faces down on a piece of cardboard.

Step 7 – Remove back panel to control module

Using your TX 20 Torx or Phillips screwdriver depending on your model, unscrew the six screws that hold the back panel on the control module.

Once you have the six screws out of the back panel you can slide it to one side of the control module giving you access to the Electro (acid) sensor board.

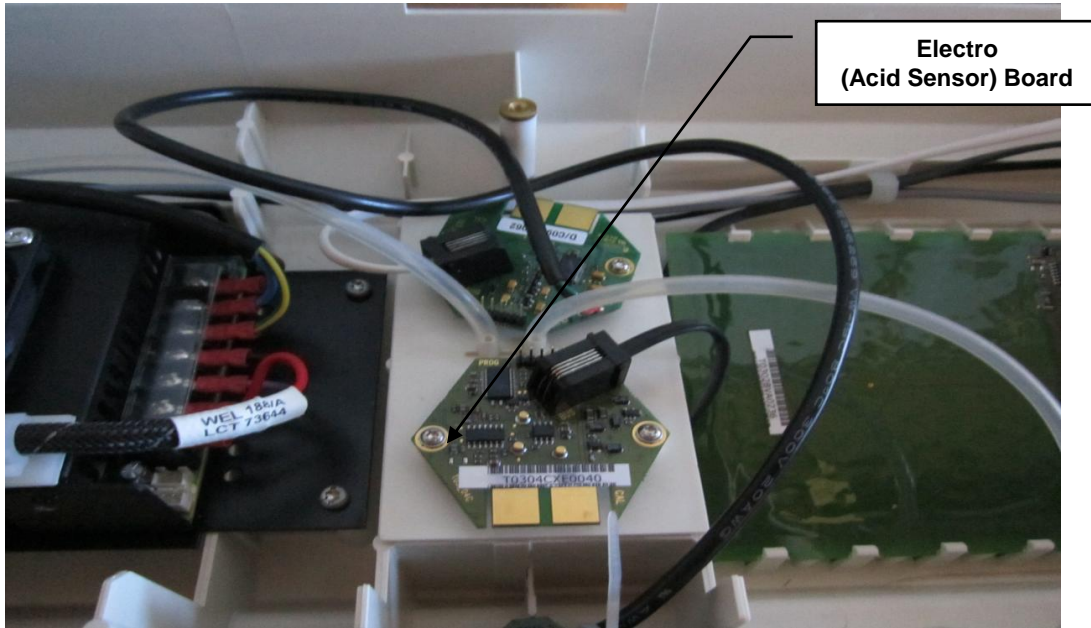
Step 8 – Disconnect and remove old sensor

First unplug the RJ9 connector from the board. It is similar to a phone cord, push the tab in on the crystal and then gently pull on the cord to release it.

Next you need your TX 10 Torx or Phillips screwdriver to remove the two screws that are holding the board to the control module housing. You should now have the board free from the controller housing.

Do not discard the old board and sensor as it needs to be sent back to Labconco for a refund of the core charge.

Chapter 6: Maintaining the Protector Filtered Hood

Step 9 – Install new sensor

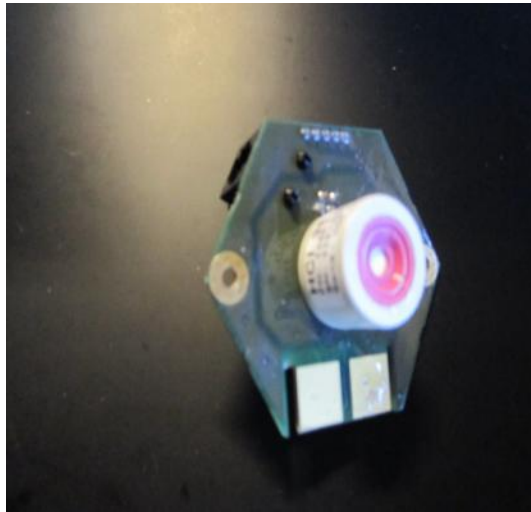

To install a new sensor, line up the holes from the board to the controller housing and make a few turns with your Torx driver or Phillips screwdriver.

Now that you have the screws partially tightened, hold the board firmly down to the housing with one hand and use the other to tighten the screws the rest of the way.

Now that the board is in place locate the RJ9 connector that you removed earlier and insert it into the board.

You should now have the board securely in place and the RJ9 connector plugged into the board.

Step 10 – Attach back panel to the controller

Before you slide the back panel over to cover up the controller check to make sure the ethernet cable is still securely attached to the female port and that the air tube inside is still connected in its spot on the back panel.

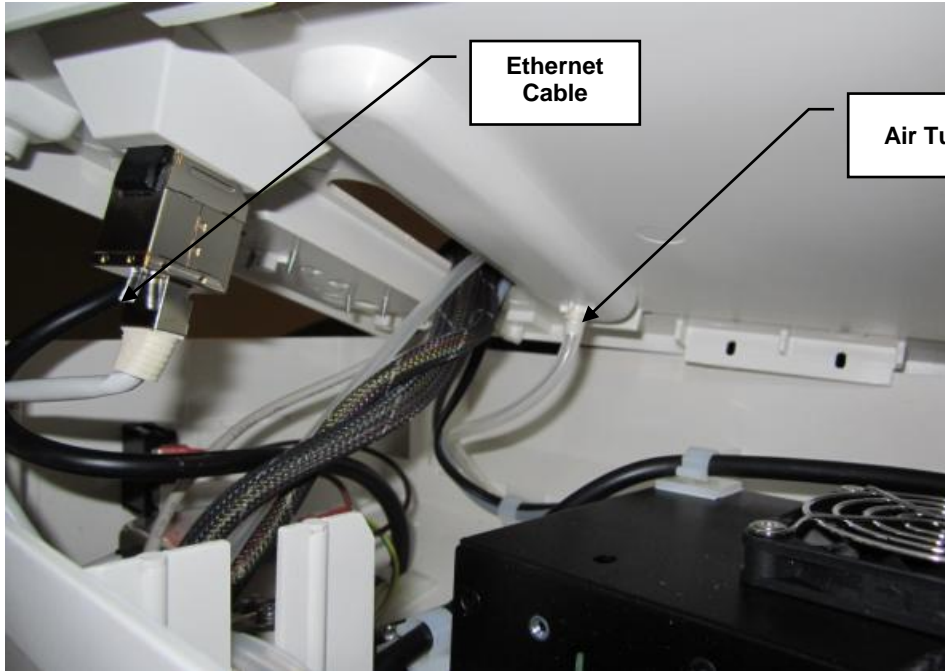

Once you are sure they are in place, slide the cover over the rest of the way and insert the six screws.

Chapter 6: Maintaining the Protector Filtered Hood

Step 11 – Snake the wires through the hood

Have your helper bring the control module back over to the hood holding the back of the controller up. Take this time to put the remaining wires up through the hood as needed.

You should have:

- Light supply wire
- Fan supply wire
- Air tube
- Temp sensor
- Sash

Step 12 – Connect the electrical cord set to the control Module

If your controller is not hardwired into the electrical system and plugged directly into an outlet on the top of the hood you may now move on to the next step.

Otherwise if it is hardwired and you must continue to follow the rest of this step.

You should now have the power cord connected to the control module by reconnecting the quick electrical connector.

Step 13 – Attach the control module to the mounting plate

Take this time to first plug in your ethernet line into the back of the controller (if applicable). Next have your helper hand it to you. Line up the bottom holes of the control module to the small arms on the bottom of the front mounting plate.

Once you have it in their slots on the bracket, push the top back to line up the two screw holes.

It is very important to have it lined up as the screws can cross thread very easily.

This time, place the right screw in first followed by the left. Check that it is securely fastened on. Once you are sure that they are secure, proceed to the next step.

Step 14 – Connect all remaining wires

Now make your connections with the wires that you snaked to the technology earlier.

You should have:

- Light supply wire from control module to light #1
- Fan supply wire from control module to fan #1
- Air tube from Control module to the “T” on fan #1
- Temp sensor
- Sash

Verify that all the connections are connected properly before you proceed on to the next step. Also make sure that none of the wires is in the way of any moving parts from the sash.

Step 15 – Turn power back on

If it was directly plugged into an outlet make sure that you plug it back in and then turn the power to the controller back on at the breaker.

Place a “Maintenance” card in the card reader.

It will say “Booting.” Check for updates and then load the OS. When it comes up it will be in alarm and you will see “hardware configuration mismatch 9A” on the screen because it does not recognize the new Electro (acid) sensor board.

You must now do a “reconfiguration” to accept the new sensor board. Follow the “Reconfiguration Process” in Chapter 3 to fix this.

If you are still having issues after a “reconfigure” call Labconco Product Service about the issue.

Also please keep in mind that there is a “burn in period” to the sensor. Sometimes it can take **24** to even **48** hours to “burn in” the new sensor.

Secure Mode (see Appendix G for details)

This can be used if the lab manager only wants the user of each hood to control the lights only. The lab manager can use an Administrator’s card and or gGuard to turn on or off the fans on the GFH.

gGuard Checklist and Software Option (see Appendix E for details)

The gGuard software is an optional package purchased separate. Appendix E includes a checklist of all system requirements needed for the gGuard hood monitoring software. It also has a list of recommendations for on-site IT to ensure proper integration of the software onto their network.

Appendix E includes an explanation of the gGuard software with basic troubleshooting tips for on-site IT if a communication issue arises. There is also a step by step guide of the installation of gGuard software with screenshots.

BACnet™ Checklist Option (see Appendix F for details)

The BACnet™ device is the ETH 1000 and can support up to 10 filtered hoods. For example, order 2 each BACnet devices for 15 hoods. Appendix F includes a checklist that has all requirements and supported drivers list. The list must be checked to ensure compatibility with the BACnet that is on-site. The BACnet option, named ETH 1000, provides BACnet capability of the filtered hood, but it is up to the IT on-site to configure the BAS Operating Workstation (BOW) according to its protocol with the data objects they want to see. See Appendix F for details.

Note: BACnet is a trademark of ASHRAE.

CHAPTER 7

ACCESSORIZING THE

PROTECTOR FILTERED HOOD

There are several ways to accessorize and/or modify the Protector Filtered Hood for your individual requirements. These include the addition of replacement Neutrodine carbon filters, HEPA filters, work surfaces, base stands, base stand shelves, seismic supports, storage cabinets, service fixtures, electrical duplex outlets, airflow monitors, sash stops, distillation grids, remote monitoring software, BACnet hardware, ADA remote control, extra user maintenance and administrator cards, and sash reduction wing kits.

Filters

The Protector Filtered Hood operates with one comprehensive Neutrodine carbon filter to adsorb solvents, acids, bases, ammonia, and formaldehyde.

Catalog #	Description
9577400	Neutrodine molecular carbon filter (universal)
9577401	Optional HEPA filter
9577402	Prefilter, located in Light Box

The Protector Filtered Hood model sizes, filter compartments, and number of filters are listed below for installation convenience.

Hood Size	Filter Compartments	Required No. of Neutrodine Filters	Total Neutrodine Filter Weight	Optional No. of HEPA Filters	Total HEPA Filter Weight
3'	1	2	50 lbs.	1	10
4'	2	4	100 lbs.	2	20
5'	3	6	150 lbs.	3	30
6'	4	8	200 lbs.	4	40
8'	5	10	250 lbs.	5	50

Chapter 7: Accessorizing the Protector Filtered Hood

Work Surfaces

A required work surface is available to attach to support the Protector Filtered Hood. The black epoxy work surfaces are contoured to fit the dimensions of the filtered hood to contain spills. May be ordered with a pre-cut 6" x 3" oval cupsink cutout. See Figure 3-1 for installation.

Use this key to configure the **seven digit catalog number** to order your SpillStopper Dished Solid Epoxy Work Surface. For example, a **9501610** is a 6' wide x 36" deep SpillStopper Work Surface, with a left rear cupsink cutout.

<p>9</p> <p>STEP 1. Select the nominal width of your filtered fume hood. This number is the fifth digit of your catalog number. Shipping weight is noted for each width.</p> <p>4 = 4' 120 lbs. (54 kg)</p> <p>5 = 5' 160 lbs. (73 kg)</p> <p>3 = 3' 90 lbs. (41 kg)</p>	<p>0</p> <p>6 = 6' 220 lbs. (100 kg)</p> <p>8 = 8' 250 lbs. (113 kg)</p>	<p>1</p> <p>STEP 3. Select a left cupsink cutout option (cupsink is sold separately). See dimensional drawing. This number is the sixth digit of your catalog number.</p> <table border="1"> <thead> <tr> <th colspan="2">Left Cupsink Cutout</th> </tr> </thead> <tbody> <tr> <td>0</td> <td>None</td> </tr> <tr> <td>1</td> <td>Rear</td> </tr> <tr> <td>2</td> <td>Side*</td> </tr> </tbody> </table>	Left Cupsink Cutout		0	None	1	Rear	2	Side*	<p>STEP 4. Select a right cupsink cutout option (cupsink is sold separately). See dimensional drawing. This number is the seventh digit of your catalog number.</p> <table border="1"> <thead> <tr> <th colspan="2">Right Cupsink Cutout</th> </tr> </thead> <tbody> <tr> <td>0</td> <td>None</td> </tr> <tr> <td>1</td> <td>Rear</td> </tr> <tr> <td>2</td> <td>Side*</td> </tr> </tbody> </table>	Right Cupsink Cutout		0	None	1	Rear	2	Side*
Left Cupsink Cutout																			
0	None																		
1	Rear																		
2	Side*																		
Right Cupsink Cutout																			
0	None																		
1	Rear																		
2	Side*																		

*Not compatible with Protector Solvent Storage Cabinets.

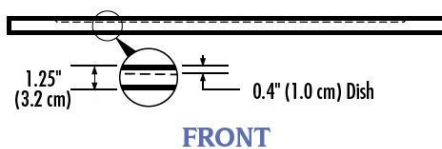
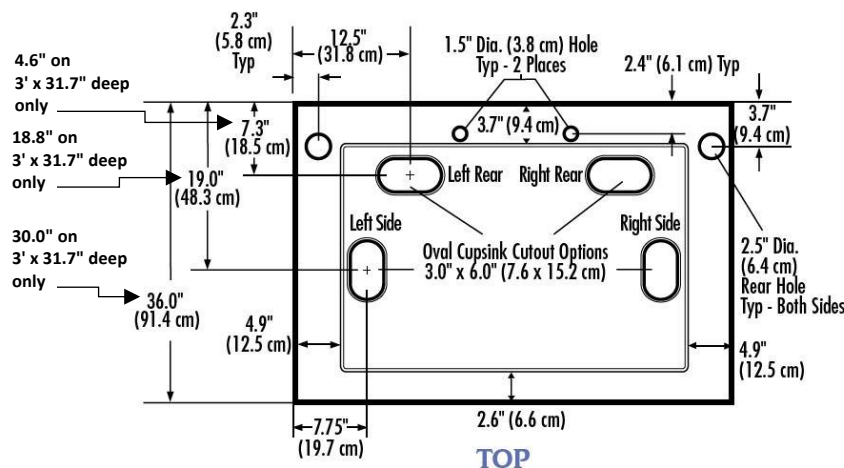

4005200 Oval Polypropylene Cupsink
Mounts in work surface with cupsink cutout, 3.0" x 6.0" (7.6 x 15.2 cm). 1.5" (5.8 cm) National Pipe Straight Mechanical (NPSM) thread. Shipping weight 4 lbs. (2 kg)

Base Stands, Accessory Shelves, Seismic Supports, and Hydraulic Lift Base Stands

The following base stands, hydraulic lift base stands, accessory shelves, and seismic supports may be used with the accessory work surfaces to support the Protector Filtered Hoods. Hydraulic Lift Base Stands allow easy movement up and down and through doorways as they are portable and can be supplied with toe-locking casters.

Catalog #	Description	Size (if applicable)
3746701	3' Base Stand w/Feet	3' x 29" x 27.5"-33.5"
3746702	4' Base Stand w/Feet	4' x 29" x 27.5"-33.5"
3746703	5' Base Stand w/Feet	5' x 29" x 27.5"-33.5"
3746704	6' Base Stand w/Feet	6' x 29" x 27.5"-33.5"
3746711	3' Base Stand w/Casters	3' x 29" x 27.5"-33.5"
3746712	4' Base Stand w/Casters	4' x 29" x 27.5"-33.5"
3746713	5' Base Stand w/Casters	5' x 29" x 27.5"-33.5"
3746714	6' Base Stand w/Casters	6' x 29" x 27.5"-33.5"
3811101	3' Shelf, Base Stand	25.4" x 32.4"
3811102	4' Shelf, Base Stand	25.4" x 44.4"
3811103	5' Shelf, Base Stand	25.4" x 56.4"
3811104	6' Shelf, Base Stand	25.4" x 68.4"
3857000	Seismic Support Bracket Kit	N/A
3780310	Portable 3' SoLo Hydraulic Lift Base Stand, 115V	53.5" x 34.3" x 17.2"-36.8"
3780314	Portable 3' SoLo Hydraulic Lift Base Stand, 230V	53.5" x 34.3" x 17.2"-36.8"
3780311	Portable 4' SoLo Hydraulic Lift Base Stand, 115V	65.5" x 34.3" x 17.2"-36.8"
3780315	Portable 4' SoLo Hydraulic Lift Base Stand, 230V	65.5" x 34.3" x 17.2"-36.8"
3780312	Portable 5' SoLo Hydraulic Lift Base Stand, 115V	77.5" x 34.3" x 17.2"-36.8"
3780316	Portable 5' SoLo Hydraulic Lift Base Stand, 230V	77.5" x 34.3" x 17.2"-36.8"
3780313	Portable 6' SoLo Hydraulic Lift Base Stand, 115V	89.5" x 34.3" x 17.2"-36.8"
3780317	Portable 6' SoLo Hydraulic Lift Base Stand, 230V	89.5" x 34.3" x 17.2"-36.8"
3780300	3' Electric Hydraulic Lift Base Stand, 115V, 60Hz	36.0" W x 29.0" Dp
3780303	3' Electric Hydraulic Lift Base Stand, 230V, 50Hz	36.0" W x 29.0" Dp
3780301	4' Electric Hydraulic Lift Base Stand, 115V, 60 Hz	48.0" W x 29.0" Dp
3780304	4' Electric Hydraulic Lift Base Stand, 230V, 50 Hz	48.0" W x 29.0" Dp
3780302	6' Electric Hydraulic Lift Base Stand, 115V, 60 Hz	72.0" W x 29.0" Dp
3780305	6' Electric Hydraulic Lift Base Stand, 230V, 50 Hz	72.0" W x 29.0" Dp
3780400	3' Manual Hydraulic Lift Base Stand	36.0" W x 29.0 Dp
3780401	4' Manual Hydraulic Lift Base Stand	48.0" W x 29.0" Dp
3780402	6' Manual Hydraulic Lift Base Stand	72.0" W x 29.0" Dp
3784000	Portable Caster Kit for Electric and Manual Hydraulic Lift Base Stands	N/A

Chapter 7: Accessorizing the Protector Filtered Hood

Storage Cabinets

The following storage cabinets may be used with the accessory work surfaces to support the Protector Filtered Hoods.

Size/Description	SOLVENT			ACID		
	Dual Doors	Right Hinge	Left Hinge	Dual Doors	Right Hinge	Left Hinge
48"	9902000	-	-	9901000	-	-
36"	9902100	-	-	9901100	-	-
30"	9902200	-	-	9901200	-	-
24"	-	9902300	9902400	-	9901300	9901500
18"	-	-	-	-	9901400	9901600
48" w/Self-Closing Doors	9903000	-	-	-	-	-
36" w/Self-Closing Doors	9903100	-	-	-	-	-
30" w/Self-Closing Doors	9903200	-	-	-	-	-
24" w/Self-Closing Doors	-	9903300	9903400	-	-	-
24" ADA	-	9906000	9906100	-	9905000	9905200
24" ADA w/Self-Closing Doors	-	9906200	9906300	-	-	-
18" ADA	-	-	-	-	9905100	9905300

Size/Description	STANDARD BASE			VACUUM PUMP		
	Dual Doors	Right Hinge	Left Hinge	Dual Doors	Right Hinge	Left Hinge
48"	9900000	-	-	-	-	-
36"	9900100	-	-	-	-	-
30"	9900200	-	-	-	-	-
24"	-	9900300	9900600	-	-	-
18"	-	9900400	9900700	-	9907000	9907100
12"	-	9900500	9900800	-	-	-

Installing Additional Service Fixtures

Additional service fixtures can be installed in the available service fixture holes in both sidewalls and corner posts. The filtered fume hood is factory set to accept up to four valves per side.

Standard Service Fixture Kits

For mounting on the left or right side of any Protector Filtered Hood. Each kit includes one remotely-controlled service fixture with valve and 0.25" diameter tubing, color-coded fixture knob and color-coded hose connector. * **Inlet tubing is not included.** Shipping weight 4 lbs. (2 kg)



Catalog #	Kit	Tubing	Valve	Knob/Connector Color	Max. Flow Rate	Max. Working Pressure†
9808300**	Cold Water (CW)	Copper	Brass	Green	3.5 GPM (13.2 LPM)	40 psi
9808400**	Air (AIR)	Copper	Brass	Orange	23.7 CFM	40 psi
9808500**	Vacuum (VAC)	Copper	Brass	Yellow	8.6 CFM	14.7 psi
9808700**	Gas (GAS)	Brass	Brass	Blue	29.0 CFM (441 BTU/sec)	40 psi
9808800**	Argon (ARG)	Copper	Brass	Gray	20.2 CFM	40 psi
9808900**	Hot Water (HW)	Copper	Brass	Red	3.5 GPM (13.2 LPM)	40 psi
9809100**	Deionized/ Distilled Water (DI)	Stainless Steel	Nickel-Plated & Stainless Steel	White	3.5 GPM (13.2 LPM)	40 psi
9809200**	Steam (STM)	Copper	Brass	Black	0.5 LBM/min	40 psi
9809300**	Nitrogen (NIT)	Copper	Brass	Brown	24.1 CFM	40 psi
9809700**††	Oxygen (OXY)	Copper	Brass with Oxygen- Compatible Lubricant	Light Green	22.6 CFM	40 psi

Cold Water Gooseneck Fixture Kits

For mounting on the left or right side of any Protector Filtered Hood. Each kit includes one remotely-controlled gooseneck with brass valve and 0.375" diameter copper tubing and green fixture knob. **Inlet tubing is not included.** Shipping Weight 10 lbs. (5 kg)

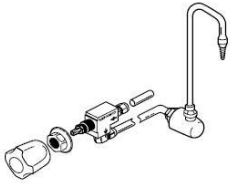

Catalog #	Kit	Description	Max. Flow Rate	Max. Working Pressure††
9827900**	Cold Water (CW) Gooseneck	For Hood with Interior Depths less than 37.7". Includes green epoxy-coated brass rigid/swivel gooseneck.	3.5 GPM (13.2 LPM)	40 psi
9857700†††	Cold Water (CW) Gooseneck	For Hoods with Interior Depths less than 37.7". Includes gray PVC rigid gooseneck.	3.5 GPM (13.2 LPM)	40 psi

Hot and Cold Water Mixing Gooseneck Fixture Kit

For any Protector Filtered Hood. Each kit includes one remotely-controlled, white epoxy-coated, brass rigid/swivel gooseneck with brass valve and 0.25" diameter copper tubing, one green fixture knob and one red fixture knob. **Inlet tubing is not included.** Shipping weight 11 lbs. (5 kg)

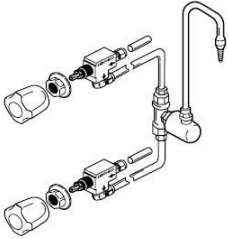

Catalog #	Kit	Description	Max. Flow Rate	Max. Working Pressure††
9828000†††	Hot (HW) and Cold Water (CW) Mixing Gooseneck	For Hoods with Interior Depths of 24" to 37.7"	3.5 GPM (13.2 LPM)	40 psi

Deionized/Distilled Water Gooseneck Fixture Kit

For mounting on the left or right side of any Protector Filtered Hood. Each kit includes one remotely-controlled, gray PVC rigid gooseneck with stainless steel valve and 0.25" diameter tubing and white fixture knob. **Inlet tubing is not included.** Shipping weight 10 lbs. (5 kg)

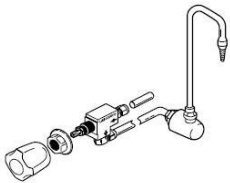

Catalog #	Kit	Description	Max. Flow Rate	Max. Working Pressure††
9853400†††	Deionized/Distilled Water (DW) Gooseneck	For Hoods with Interior Depths less than 37.7"	3.5 GPM (13.2 LPM)	40 psi

GPM=gallons per minute LPM=liters per minute CFM=cubic feet per minute BTU/sec=British thermal unit per second LBM/min=pounds mass per minute

* Contact Labconco for ordering information on Standard Service Fixtures with chrome-plated brass hose connectors for Protector Stainless Steel Hoods.

† Maximum allowable pressure is 200 psi with a working pressure of 40 psi. **Protector Stainless Steel and PVC Hoods require drilled hole in liner.

†† WaterSaver is a registered trademark of WaterSaver Company.

††† Requires 1.375" dia. drill hole in liner.

Installing an Electrical Duplex Outlet

Your Protector Filtered Fume Hood can be ordered with duplex outlets, however, if you ordered a model without an electrical duplex outlet you can have one installed in the field by a qualified electrician.

Electrical Receptacle Kits

For mounting in left or right side of any 3', 4', 5', 6' or 8' Protector Filtered Hood. Each Receptacle Kit includes an electrical receptacle, wiring, junction box and receptacle cover plate. The international GFCI Switch is mountable in one corner post location above or below any international single outlet.



9851500 Duplex Electrical Receptacle Kit, 115 volts, 20 amps AC, GFCI, 60 Hz

Catalog #	Kits	Outlet Type	Shipping Wt. lbs./kg
9851100	115 volts, 20 amps AC, 60 Hz	Duplex, U.S.	4/2
9851500	115 volts, 20 amps AC, GFCI, 60 Hz	Duplex, U.S.	4/2
9854200	230 volts, 20 amps AC, 60 Hz	Duplex, U.S.	4/2
9412500	230 volts, 13 amps AC, 50 Hz	Single, British (UK)	4/2
9412700	230 volts, 16 amps AC, 50 Hz	Single, Schuko	4/2
9412900	230 volts, 10 amps AC, 50 Hz	Single, China	4/2
9413100	230 volts, 10 amps AC, 50 Hz	Single, Australia	4/2
9413900	230 volts, 6-16 amps AC, 50 Hz	Single, India-South Africa	4/2
9414100	International GFCI Switch, 16 amps	Not Applicable	4/2



British (UK)



Schuko



China



Australia



India-South Africa

NOTE: If needed, the individual duplexes can be converted for instant attachment to a wall outlet by a qualified electrician by ordering an electrical outlet as harness listed below:

9582710	Electrical Outlet Harness, 115V-15A US Plug 5-15P
9582712	Electrical Outlet Harness, 115V-20A US Plug 5-20P
9582720	Electrical Outlet Harness, 230V-15A US Plug 6-15P

Installing Optional Guardian™ Digital Airflow Monitor

The optional Guardian Digital Airflow Monitor continuously monitors face velocity through the fume hood opening. The fume hood left corner post is factory prepared to mount the monitor. Note: The digital air monitor audio alarm can be permanently muted if so desired.

Optional Guardian™ Digital Airflow Monitors

Guardian Digital Airflow Monitor senses and alerts the operator to low airflow conditions. LCD displays actual airflow in fpm or m/sec. Audible/visual alarm alerts the user to sustained low velocity condition. Calibration instructions displayed on LCD. Each monitor also includes a temperature-compensated sensor, external alarm, night setback and alarm mute functions. Flush-mount design on Protector Filtered Hoods. Contact Labconco for optional RS-485 port for Modbus** RTU communications.



Catalog #	Ranges	For use with Hood:	Shipping Wt. lbs./kg
9413400	100-115 volts, 50/60 Hz	Protector Filtered Hood	6/3
9413401*	208-230 volts, 50/60 Hz	Protector Filtered Hood	6/3

*International electrical configuration

**Modbus is a registered trademark of Schneider Automation

Sash Stop Kit – Field Installation

The sash stop kit restricts how far a vertical-rising sash may be opened. This small plastic device may be easily field installed on the fixture corner post of any fume hood.

<u>Part No.</u>	<u>Description</u>
9410300	Sash Stop Kit Left Side (included)
9410303	Sash Stop Kit Right Side

Distillation Grids – Field Installation

The distillation grids have been strategically placed so that the vertical rod center lines up in front of the lower baffle and middle baffle. The distillation grids allow the hood user to mount glassware, motors, stirrers and other apparatus.

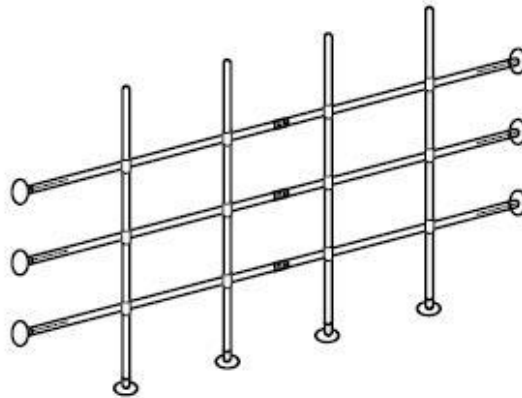

Distillation Grid Kits

Kits include stainless steel rods, connectors, instruction sheet and drill template. **Requires installation including drill holes.**

Catalog No.	Description
9725204	4 Feet
9725205	5 Feet
9725206	6 Feet
9725200	8 Feet

Installing Remote Monitoring Software

The optional gGuard Remote Monitoring Software (P/N 9581100) is available as an automatic collection and record of hood data, alerts, and alarms on the customer's network personal computer. gGuard Remote Monitoring Software monitors, manages and provides data via e-mail to a designated facility manager. See Appendix E for more details.

Installing BACnet Gateway Hardware

The BACnet option (P/N 9581101), named ETH1000, provides BACnet capability of the filtered hood, but it is up to the IT on-site to configure the BAS Operating Workstation (BOW) according to its protocol with the data objects they want to see. See Appendix F for details. Each BACnet can support up to ten filtered hoods maximum.

ADA Remote Control

The ADA Remote Control (P/N 9579700) allows the wheelchair personnel and/or shorter workers to access the fan and light switches through a wireless remote control.

Additional User, Maintenance, and Administrator Access Cards

The Protector Filtered Hood requires an Identification Card for use, service and administration. Order the extra cards as listed below:

<u>Part No.</u>	<u>Description</u>
9580900	Administrator Card (majority of access)
9580901	User Card (limited access, must be programmed)
9580902	Maintenance Card (complete access)

Note: The User Card only allows limited access such as fan and light control.

Sash Reduction Wing Kits (for 100 fpm at 16")

Some installations require 100 fpm. The Protector Filtered Hood operates at 60 fpm at the 16" sash stop position. The accessory Sash Reduction Wing Kits allow the face velocity to be increased to 100 fpm at the same 16" sash stop position and act as an Airflow Regulating Side Shield. The Sash Reduction Wing Kits are hinged with detents to maintain open and closed positions. Open position is used for loading equipment and closed position is used for normal operation. An optional accessory airflow monitor is available for sash position alarms. Alternatively to ordering the Sash Reduction Wing Kits, the end user can simply lower the 16" sash stop to the 10" sash stop position. Sash Reduction Wing Kits promote comfort for some users that prefer a 16" sash opening rather than a 10" sash opening.

Part Number	Description	Sash Opening	Face Velocity	Sash Wing Width
9584904	4' Sash Reduction Wing Kit	18" w x 16" h	100 fpm	10"
9584905	5' Sash Reduction Wing Kit	26" w x 16" h	100 fpm	12"
9584906	6' Sash Reduction Wing Kit	34" w x 16" h	100 fpm	14"
9584908	8' Sash Reduction Wing Kit	48" w x 16" h	100 fpm	19"

CHAPTER 8

TROUBLESHOOTING

Refer to the following table if your filtered fume hood fails to operate properly. If the suggested corrective actions do not solve your problem, contact Labconco for additional assistance. Furthermore, consult the “User Alarm Code List” in Chapter 6 for all alarms and alerts.

PROBLEM	CAUSE	CORRECTIVE ACTION
Fans and lights won't operate	Wires not connected at junction boxes or switches.	Check connection of wires. Check connection to control box on front of unit.
	Circuit breakers tripped in building electrical supply.	Reset circuit breakers.
	Fan operates but lights will not operate	Lamp not installed correctly.
	Lamp is defective.	Replace lamp.
	Lamp circuit breaker in building is tripped.	Reset the lamp circuit breaker.
	Fuse on control panel is defective.	Replace fuse.

Chapter 8: Troubleshooting

PROBLEM	CAUSE	CORRECTIVE ACTION
Fan operates but lights will not operate	Lamp wiring is disconnected.	Inspect lamp wiring.
	Defective lamp ballasts.	Replace light box.
Contaminants outside of fume hood	Improper user techniques for the filtered fume hood.	See “Certifying the Filtered Hood” Chapter 3 and “Safety Precautions” Chapter 4 sections in the manual. (Ref. Appendix I)
	External factors are disrupting the filtered fume hood airflow patterns or acting as a source of contamination.	See “Location Requirements” Chapter 2, “Certifying the Filtered Hood” Chapter 3, and “Safety Precautions” Chapter 4 sections of this manual. (Ref. Appendix I)
	Filtered fume hood has improper face velocity.	Have fume hood re-certified. Check sash stop locations and fan(s) operation. Hood should have average face velocity of 60-100 fpm.
Vertical sash no longer operates smoothly	Cable is frayed or plastic protection is damaged.	Inspect cable and replace cable if worn or damaged immediately; otherwise injury could result.
	Pulley bearing is damaged.	Replace pulley, bearing or add grease.
	Cable or chain has slipped off the pulleys or sprockets.	Re-install, cable or chain must be replaced immediately if damaged.
	Weight has broken pulleys or sprockets.	Replace pulleys or sprockets.
	Vertical sash frame is distorted.	Place horizontal glass symmetrically and pull sash down to air foil. Straighten damaged frame.
	Cable is frayed or has slipped off the pulleys.	Re-install, cable must be replaced immediately if damaged.

PROBLEM	CAUSE	CORRECTIVE ACTION
Electrical duplex outlets no longer have power	Wires not connected or faulty duplex.	Check wire connection or replace duplex.
	Circuit breakers tripped in building electrical supply.	Reset circuit breakers.
Service valves no longer operate	Faulty building supply.	Inspect building supply shut off valves and appropriate pressures below the recommended 40 PSI.
	Valve no longer operates.	Replace valve and check for leaks.
	Supply line or outlet line has leaks.	Inspect line for leaks and fix any leaking plumbing connections.

APPENDIX A

PROTECTOR FILTERED HOOD

REPLACEMENT COMPONENTS

Illustration A-1 indicate the location of the following service parts:

Protector Filtered Hood Replacement Parts

Item	Quantity	Part No.	Description
1A	1	9823700	Valve, Labconco (Water) 1/4" Compression Fitting
1B	1	9823701	Valve, Labconco (Water) 3/8" Compression Fitting
1C	1	9817000	Valve, Labconco 1/4" Compression Fitting (AIR, GAS, VAC, NIT, etc.)
1D	1	9817001	Valve, Labconco 3/8" Compression Fitting (AIR, GAS, VAC, NIT, etc.)
1E	1	9823702	Valve, Labconco Deionized 1/4" Compression Fitting
1F	1	9823703	Valve, Labconco Deionized 3/8" Compression Fitting
1G	1	9818000	Nut, Valve Mounting. (Labconco)
2A	1	9826800	WaterSaver Valve/Gooseneck -GRN
2B	1	9826801	WaterSaver Valve/Connector (VAC) – YEL
2C	1	9826802	WaterSaver Valve/Connector (AIR) – ORG
2D	1	9826803	WaterSaver Valve/Connector (GAS) – BLU
2E	1	9826805	WaterSaver Valve/Connector (HOT WATER) – RED
2F	1	9826806	WaterSaver Valve/Connector (CW) – GRN
2G	1	9826807	WaterSaver Valve/Connector (STEAM) – BLK
2H	1	9826808	WaterSaver Valve/Connector (NITROGEN) – BRN
2I	1	9826809	WaterSaver Valve/Connector (OXYGEN) – LIGHT GREEN
2J	1	9826810	Swivel Gooseneck only – GRN
2K	1	9826812	Swivel Gooseneck only – WHITE
3	1	9818700 thru 08	Knobs (GRAY, GRN, BLU, ORG, YEL, RED, WHT, BLK, BRN)
4A	1	9818800	Hose Barb, GRAY – (NEUTRAL OR ARGON) – NOT SHOWN
4B	1	9818801	Hose Barb, GREEN - (COLD WATER) – NOT SHOWN
4C	1	9818802	Hose Barb, BLUE – (GAS) – NOT SHOWN
4D	1	9818803	Hose Barb, ORANGE – (AIR) – NOT SHOWN
4E	1	9818804	Hose Barb, YELLOW – (VACUUM) – NOT SHOWN
4F	1	9818805	Hose Barb, RED – (HOT WATER) – NOT SHOWN
4G	1	9818806	Hose Barb, WHITE – (DEIONIZED WATER) – NOT SHOWN
4H	1	9818807	Hose Barb, BLACK – (NEUTRAL OR STEAM) – NOT SHOWN
4I	1	9818808	Hose Barb, BROWN – (NITROGEN) – NOT SHOWN
4J	1	9819000	Nut, Hose Barb – NOT SHOWN
5	1	9825500	Label, Knob (contains all the labels)
6	1	9818900	Lens, Knob
7A	1	9947100, 01, 02	115V Duplex Receptacle (GRAY) Right, Left 4' - 6', Left 8' w/ wires
7B	1	9818200	Cover Plate 115V Duplex
7C	1	9947103, 04, 05	115V GFCI Duplex Receptacle (GRAY) Right 4' - 6', Left 8' w/ wires
7D	1	9818100	Cover Plate, 115V GFCI
7E	1	9818300	Cover Plate, Blank

Appendix A: Protector Filtered Hood Components

Item	Quantity	Part No.	Description
7F	1	9851203	115V Duplex Receptacle, Left 10' - 12' (Gray)
7G	1	9851303	115V Duplex Receptacle, Left 16' (Gray)
7H	1	9851603	115V GFCI Duplex Receptacle, Left 10' - 12' (Gray)
7I	1	9851703	115V GFCI Duplex Receptacle, Left 16' (Gray)
8	1	9818400	Access Cover
9A	2	9580304	Side Panel, no glass
9B	1	9580303	Side Panel, with window – Left
9C	1	9580302	Side Panel, with window – Right
9D	4	1885308	Screw, Machine #10-24 x .50 Phillips
9E	2	9543900, 02, or 04	Side Panel, Floor Mount Lower Base, 37.7", 43.7" or 55.7"
10A	1	9436500	Eco-Foil 3'
10B	1	9436501	Eco-Foil 4'
10C	1	9436502	Eco-Foil 5'
10D	1	9436503	Eco-Foil 6'
10E	1	9436505	Eco-Foil 8'
11	4	1850000	Pulley, Rear, 2" Dia. Nylon
12A	2	4949902	Cable, Sash 130" – NOT SHOWN
12B	2	9414017	Cable Replacement Kit, Echo
12C	1	9545800	Weight Support Bracket Kit (not available for 360° visibility)
13	2	9709300	Plastic Pulley, (Front 2")
14	2	9713300	Bumper, Rubber – NOT SHOWN (lower sash bumper)
15	4	1934102	Bronze Bearing, Flanged Front, .375 OD x .281 ID – NOT SHOWN
16	4	1920100	Clamp, Cable Replacement – NOT SHOWN
17	2	9935800	Threaded Connector – NOT SHOWN (to attach weight to cable)
18	1	9582700, 01	Wiring Harness (may be used to power optional air monitor)
19A	1	9409601, 02, 03, 05	Front Panel, 4', 5', 6', 8'
19B	1	9582600	Echo Label, Front Panel
20	1	9578100, 01, 02, 03	Rear Panel, 360° visibility only 4', 5', 6', 8'

Neutrodine (by Erlab) Filtration Technology Replacement Parts

Item	Quantity	Part No.	Description
21AA	1	9577303	3' (M1) Complete Airo Technology Package, no filters
21A	1	9577304	4' (M2) Complete Echo/Airo Technology Package, no filters
21B	1	9577305	5' (M3) Complete Echo Technology Package, no filters
21C	1	9577306	6' (M4) Complete Echo Technology Package, no filters
21D	1	9577308	8' (M5) Complete Echo Technology Package, no filters
22	1, 2, 3, 4, 5	9577400	Neutrodine molecular carbon filter (rotate every two years)
23	1, 2, 3, 4, 5	9577401	HEPA Filter
24	1, 2, 3, 4, 5	9577402	GFH Prefilter (inside light box)
25A	1	9577403	Acid Gas Sensor, Alarming (replace every two years)
25B	1	9577404	Control Panel, Electronic Box with acid sensor
25C	1	9577405	RFID PCB
25D	1	9577406	GFH CPU
26	1	9577500	Gutter, Base Filter Package
27A	1	9577800	Light Module, Filter Package
27B	1	9577801	Light PCB
27C	1	9580801	Cable, Light Power
27D	1	9577700	Replacement Light Bulb (Phillips MASTER PL-L 18W/840/4P)
28A	1	9577600	Fan Module, Filter Package
28B	1	9577601	Fan PCB
28C	1	9580800	Cable, Fan Power
28D	1	9577602	Fan, 24V, 175mm
29	1	9579300	Sash Sensor (retractable sash reel)

Appendix A: Protector Filtered Hood Components

Item	Quantity	Part No.	Description
30	1	9579500	Temperature Sensor
31	1	9581100	gGuard Remote Monitoring Software (NOT SHOWN)
32	1	9581101	BACnet Gateway (NOT SHOWN)
33	1	9579700	ADA Remote Control
34A	1	9580900	Administrator Card
34B	1	9580901	User Card (requires programming)
34C	1	9580902	Maintenance Card

Appendix A: Protector Filtered Hood Components

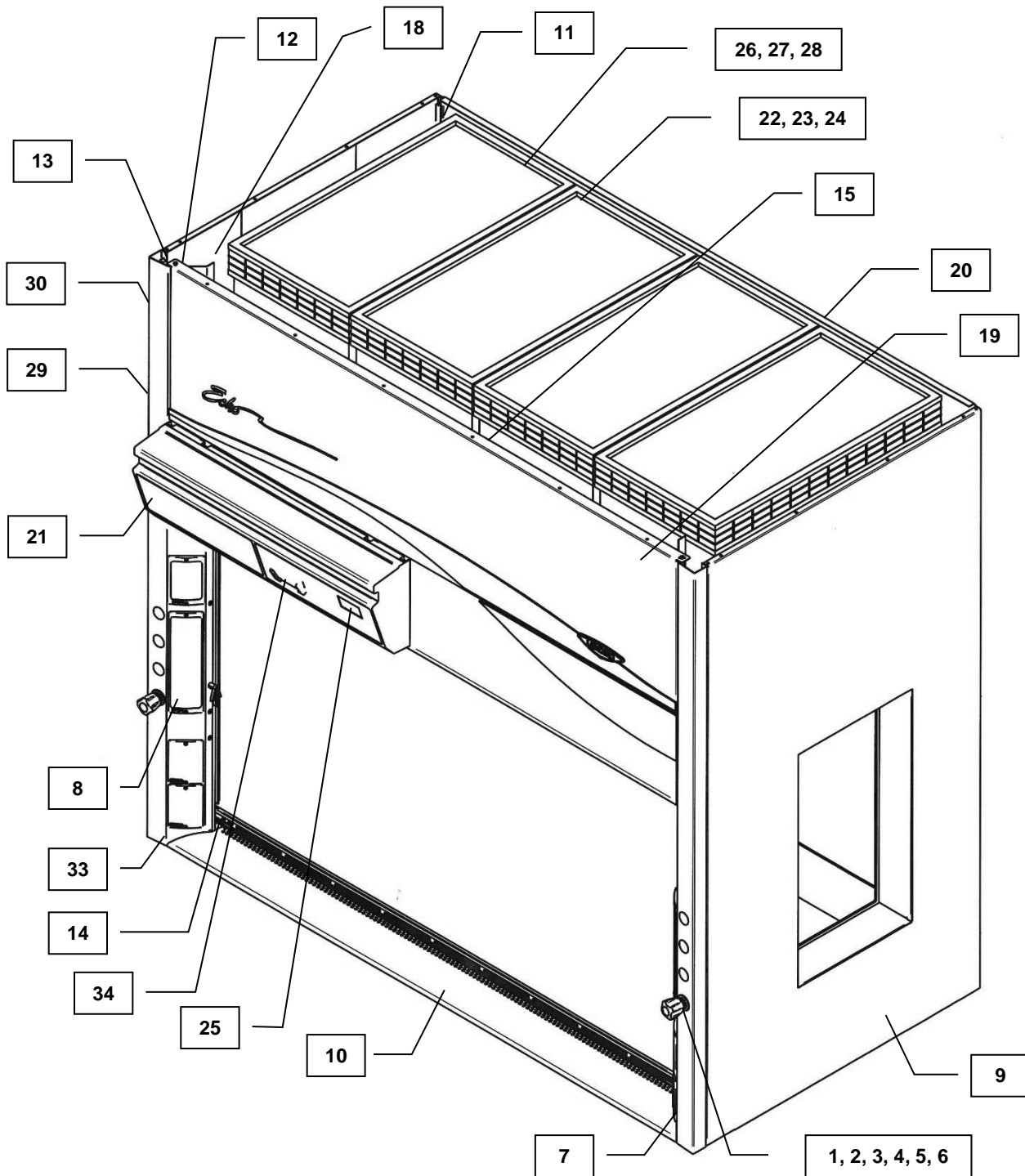

Figure A-1

APPENDIX B

PROTECTOR FILTERED HOOD

DIMENSIONS

The following pages provide dimensional data for the Protector Echo Benchtop (Figure B-1) and the Protector Echo Floor-Mounted (Figure B-2) Filtered Fume Hoods.

Note: For small 54.2" height Airo's and their dimensions, reference Appendix K.

Appendix B: Protector Filtered Hood Dimensions

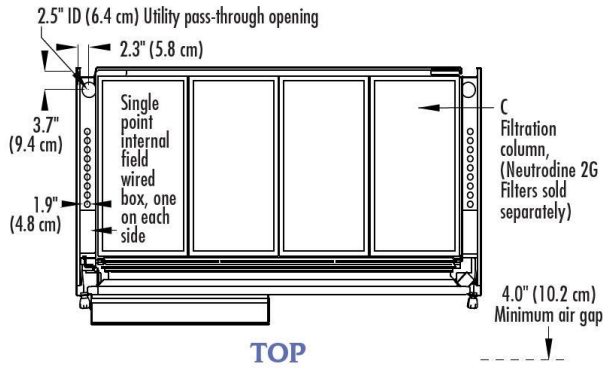

	A	B	C	D
4' Hood	48.0" (121.9 cm)	38.2" (97.0 cm)	2 ea	27.9" (70.9 cm)
5' Hood	60.0" (152.4 cm)	50.2" (127.5 cm)	3 ea	36.9" (93.7 cm)
6' Hood	72.0" (182.9 cm)	62.2" (158.0 cm)	4 ea	49.9" (126.7 cm)
8' Hood	96.0" (243.8 cm)	86.2" (218.9 cm)	5 ea	66.9" (169.9 cm)

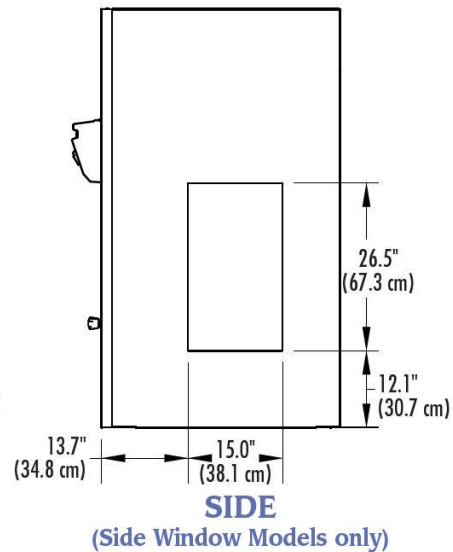
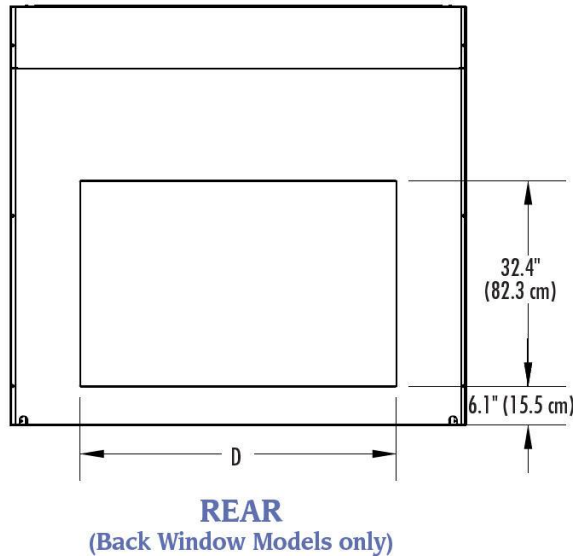
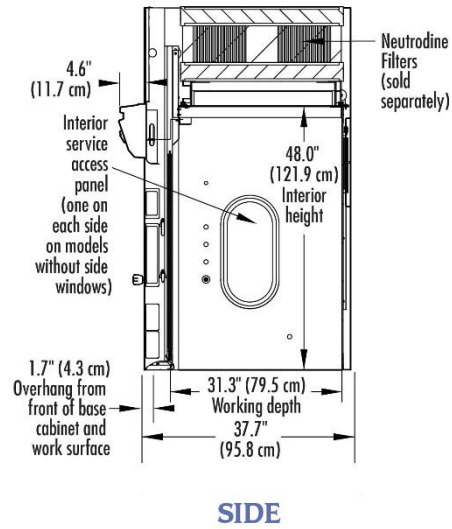
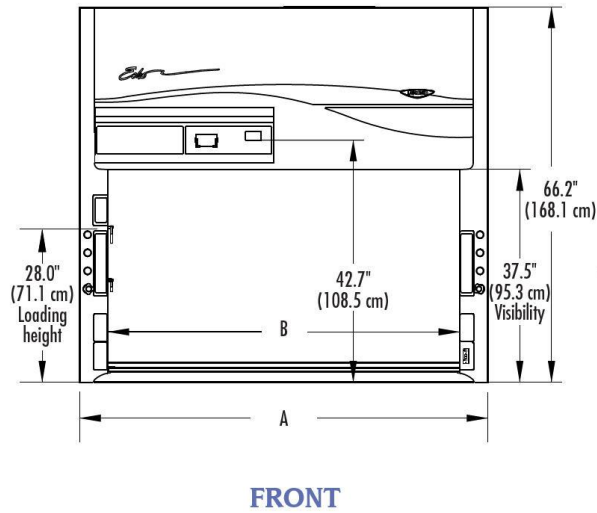

Figure B-1
Protector Echo Benchtop Filtered Fume Hoods

Appendix B: Protector Filtered Hood Dimensions

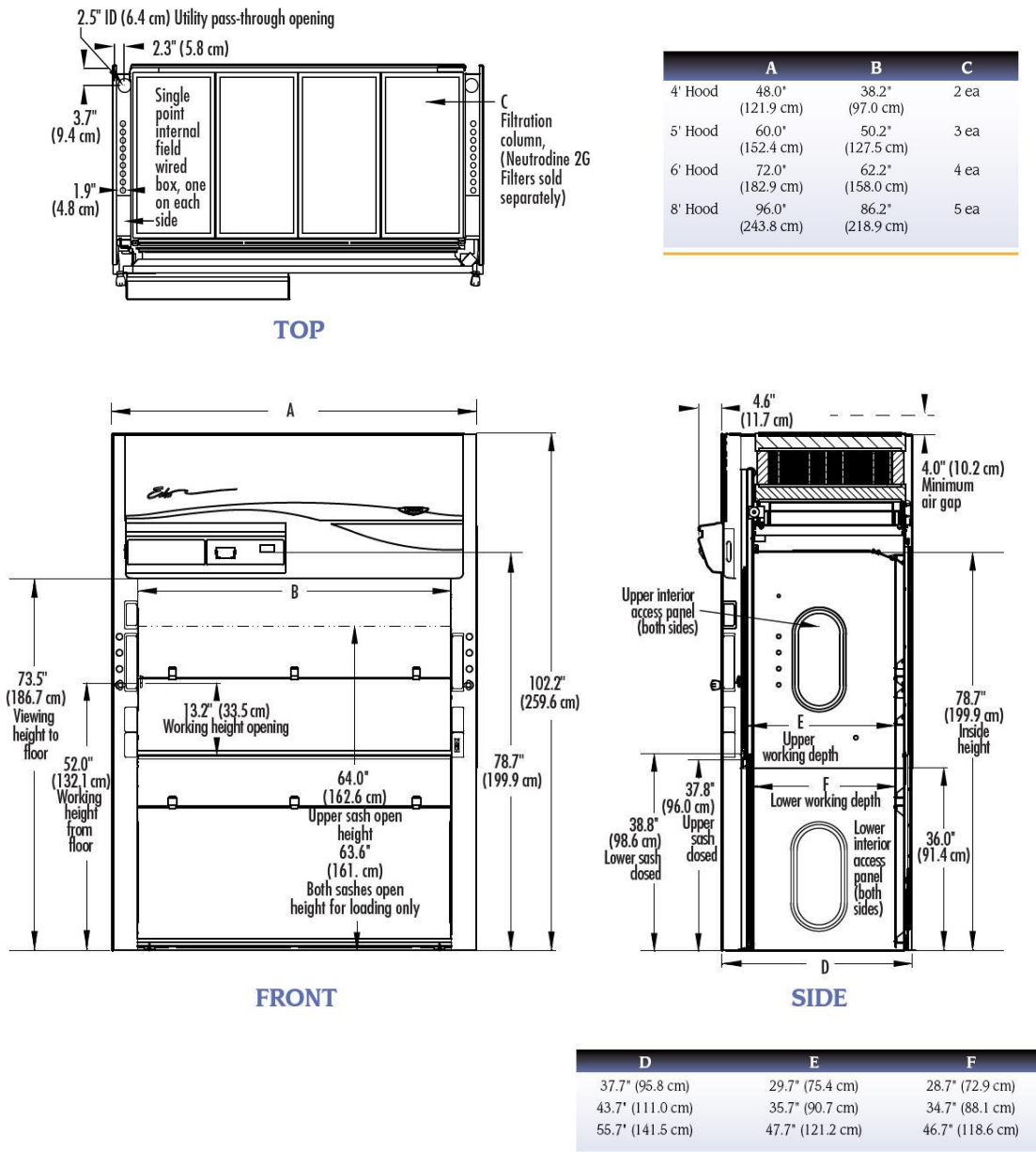

Figure B-2
Protector Echo Floor-Mounted Filtered Fume Hoods

APPENDIX C

PROTECTOR FILTERED HOOD

SPECIFICATIONS

Environmental Conditions

- Indoor use only.
- Maximum altitude: 10,000 feet (3,048 meters).
- Ambient temperature range: 41° to 104°F (5° to 40°C).
- Maximum relative humidity: 80% for temperatures up to 88°F (31°C), decreasing linearly to 50% relative humidity at 104°F (40°C).
- Main supply voltage fluctuations not to exceed $\pm 10\%$ of the nominal voltage.
- Transient over-voltages according to Installation Categories II (Over-voltage Categories per IEC 1010). Temporary voltage spikes on the AC input line that may be as high as 1500V for 115V models and 2500V for 230V models are allowed.
- Used in an environment of Pollution degrees 2 (i.e., where normally only non-conductive atmospheres are present). Occasionally, however, a temporary conductivity caused by condensation must be expected, in accordance with IEC 664.
- Electrical Ratings

<u>Volts AC</u>	<u>Phase</u>	<u>Cycle</u>	<u>AMP*</u>
115	1	50/60	10
115	1	50	10
115	1	60	10
230	1	50/60	5
230	1	50	5
230	1	60	5

*Does not include current rating of receptacles.

Appendix C: Protector Filtered Hood Specifications

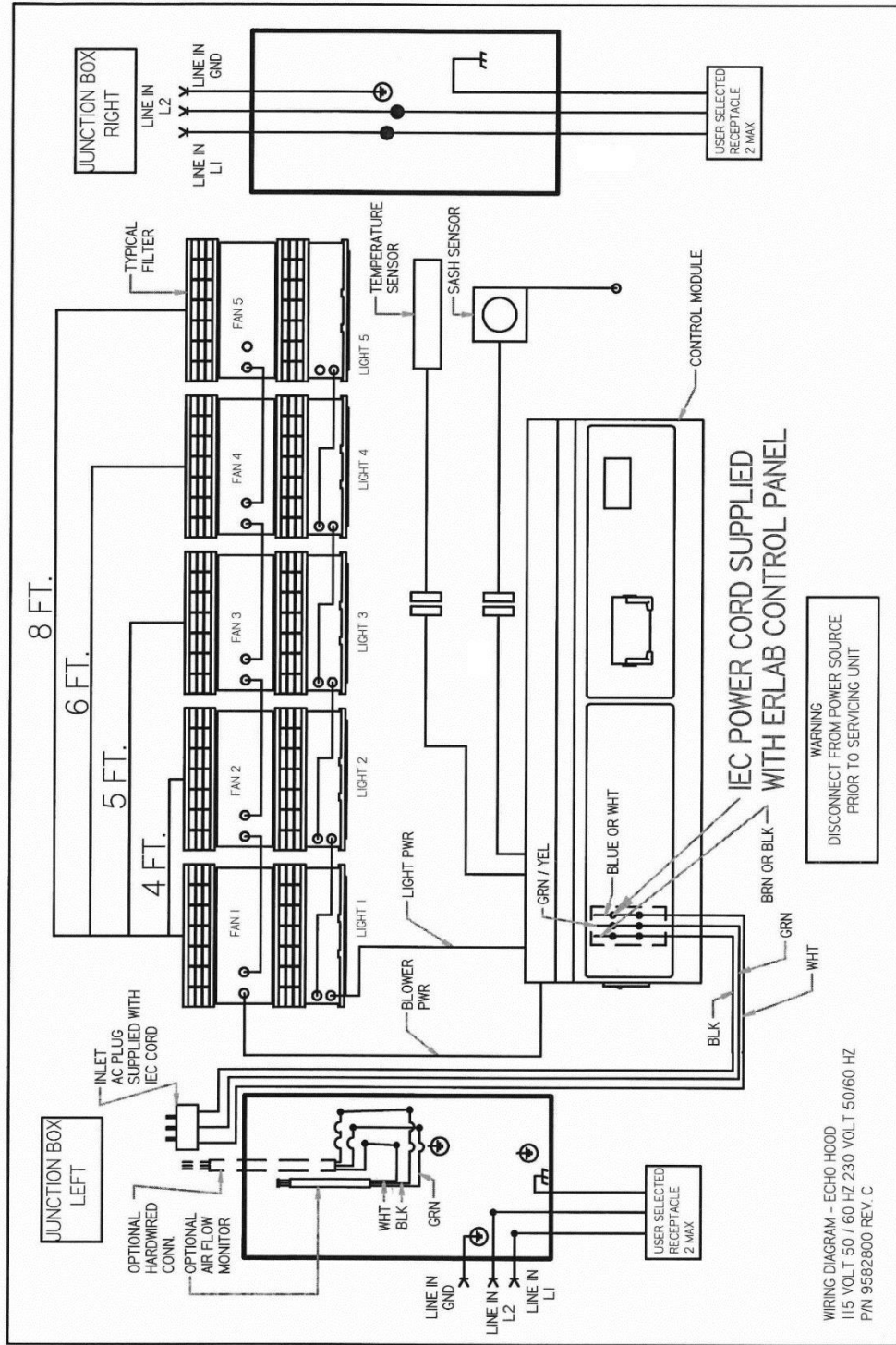

APPENDIX D

SERIAL NUMBER TAG

DESCRIPTION

Serial tag includes standard information with the following changes:

The portion of the tag for electrical information is labeled with the following units: Volts AC, Phase, Cycle, AMP.

Each hood will include one of the following:

<u>Volts AC</u>	<u>Phase</u>	<u>Cycle</u>	<u>AM</u>  <u>X</u>
115	1	50/60	10X
115	1	50	10X
115	1	60	10X
230	1	50/60	5X
230	1	50	5X
230	1	60	5X

Where  may be a separate label indicating: Caution, See Manual.

The X above will be one of several possible alpha characters as defined in the manual as follows:

- X: No additional duplexes on hood, noted amperage applies.
- B: This fume hood includes **one** additional electrical receptacle, individually wired to the field wired box and individually rated as 115V, single phase, 60Hz, 20 Amps. Each duplex can be wired on a dedicated circuit rated at 20A or the duplexes may be ganged together on the same circuit with the total load of the ganged duplexes not exceeding the 20A electrical service they are wired to.
- C: This fume hood includes **two** additional electrical receptacles, individually wired to the field wired box and individually rated as 115V, single phase, 60Hz, 20 Amps. Each duplex can be wired on a dedicated circuit rated at 20A or the duplexes may be ganged together on the same circuit with the total load of the ganged duplexes not exceeding the 20A electrical service they are wired to.

Appendix D: Serial Number Tag Description

- D: This fume hood includes **three** additional electrical receptacles, individually wired to the field wired box and individually rated as 115V, single phase, 60Hz, 20 Amps. Each duplex can be wired on a dedicated circuit rated at 20A or the duplexes may be ganged together on the same circuit with the total load of the ganged duplexes not exceeding the 20A electrical service they are wired to.
- E: This fume hood includes **four** additional electrical receptacles, individually wired to the field wired box and individually rated as 115V, single phase, 60Hz, 20 Amps. Each duplex can be wired on a dedicated circuit rated at 20A or the duplexes may be ganged together on the same circuit with the total load of the ganged duplexes not exceeding the 20A electrical service they are wired to.
- F: This fume hood includes **one** additional electrical receptacle, individually wired to the field wired box and individually rated as 230V, single phase, **60Hz**, 10 Amps. Each duplex can be wired on a dedicated circuit rated at 10A or the duplexes may be ganged together on the same circuit with the total load of the ganged duplexes not exceeding the 10A electrical service they are wired to.
- G: This fume hood includes **two** additional electrical receptacles, individually wired to the field wired box and individually rated as 230V, single phase, **60Hz**, 10 Amps. Each duplex can be wired on a dedicated circuit rated at 10A or the duplexes may be ganged together on the same circuit with the total load of the ganged duplexes not exceeding the 10A electrical service they are wired to.
- H: This fume hood includes **three** additional electrical receptacles, individually wired to the field wired box and individually rated as 230V, single phase, **60Hz**, 10 Amps. Each duplex can be wired on a dedicated circuit rated at 10A or the duplexes may be ganged together on the same circuit with the total load of the ganged duplexes not exceeding the 10A electrical service they are wired to.
- J: This fume hood includes **four** additional electrical receptacles, individually wired to the field wired box and individually rated as 230V, single phase, **60Hz**, 10 Amps. Each duplex can be wired on a dedicated circuit rated at 10A or the duplexes may be ganged together on the same circuit with the total load of the ganged duplexes not exceeding the 10A electrical service they are wired to.
- K: This fume hood includes **one** additional electrical receptacle, individually wired to the field wired box and individually rated as 230V, single phase, **50Hz**, 10 Amps. Each duplex can be wired on a dedicated circuit rated at 10A or the duplexes may be ganged together on the same circuit with the total load of the ganged duplexes not exceeding the 10A electrical service they are wired to.
- L: This fume hood includes **two** additional electrical receptacles, individually wired to the field wired box and individually rated as 230V, single phase, **50Hz**, 10 Amps. Each duplex can be wired on a dedicated circuit rated at 10A or the duplexes may be ganged together on the same circuit with the total load of the ganged duplexes not exceeding the 10A electrical service they are wired to.

- M: This fume hood includes **three** additional electrical receptacles, individually wired to the field wired box and individually rated as 230V, single phase, **50Hz**, 10 Amps. Each duplex can be wired on a dedicated circuit rated at 10A or the duplexes may be ganged together on the same circuit with the total load of the ganged duplexes not exceeding the 10A electrical service they are wired to.
- N: This fume hood includes **four** additional electrical receptacles, individually wired to the field wired box and individually rated as 230V, single phase, **50Hz**, 10 Amps. Each duplex can be wired on a dedicated circuit rated at 10A or the duplexes may be ganged together on the same circuit with the total load of the ganged duplexes not exceeding the 10A electrical service they are wired to.

ANNEXE D

DESCRIPTION DE SÉRIE TAG NUMBER

Étiquette de série comprend des informations standard avec les modifications suivantes:

La partie de l'étiquette d'information électrique est étiqueté avec les unités suivantes: Volts AC, phase, cycle, AMP.

Chaque hotte comprendra une des opérations suivantes:

<u>Volts AC</u>	<u>Phase</u>	<u>Cycle</u>	<u>AMP</u> 
115	1	50/60	10X
115	1	50	10X
115	1	60	10X
230	1	50/60	5X
230	1	50	5X
230	1	60	5X

Où  peut-être une étiquette distincte indiquant: Attention, consultez le manuel.

Le X ci-dessus sera l'un des plusieurs caractères alphabétiques possibles telles que définies dans le manuel comme suit:

- X: Pas de duplex supplémentaires sur le capot, noté ampérage s'applique.
- B: Cette hotte comprend un réceptacle électrique supplémentaire, individuellement raccordés aux boîtiers câblées individuellement et classé comme 115V, monophasé, 60 Hz, 20 ampères. Chaque duplex peut être branché sur un circuit dédié évalué à 20A ou les duplex peuvent être groupés ensemble sur le même circuit que la charge totale des duplex couplées ne dépassant pas le service électrique 20A ils sont câblés.
- C: Cette hotte comprend deux autres prises électriques, individuellement câblés à la boîte câblées individuellement et classé comme 115V, monophasé, 60 Hz, 20 A. Chaque duplex peut être branché sur un circuit dédié évalué à 20A ou les duplex peuvent être groupés ensemble sur le même circuit que la charge totale des duplex couplées ne dépassant pas le service électrique 20A ils sont câblés.
- D: Cette hotte comporte trois prises électriques supplémentaires, individuellement câblés à la boîte câblées individuellement et classé comme 115V, monophasé, 60 Hz, 20 A. Chaque duplex peut être branché sur un circuit dédié évalué à 20A ou les duplex peuvent être groupés ensemble sur le même circuit que la charge totale des duplex couplées ne dépassant pas le service électrique 20A ils sont câblés.

- E: Cette hotte comprend quatre autres prises électriques, individuellement câblés à la boîte câblées individuellement et classé comme 115V, monophasé, 60 Hz, 20 A. Chaque duplex peut être branché sur un circuit dédié évalué à 20A ou les duplex peuvent être groupés ensemble sur le même circuit que la charge totale des duplex couplées ne dépassant pas le service électrique 20A ils sont câblés.
- F: Cette hotte comprend un réceptacle électrique supplémentaire, individuellement raccordés aux boîtiers câblées individuellement et classé comme 230V, monophasé, 60 Hz, 10 ampères. Chaque duplex peut être branché sur un circuit dédié classé au 10A ou les duplex peuvent être groupés ensemble sur le même circuit que la charge totale des duplex couplées ne dépassant pas le service électrique 10A ils sont câblés.
- G: Cette hotte comprend deux autres prises électriques, individuellement câblés à la boîte câblées individuellement et classé comme 230V, monophasé, 60 Hz, 10 ampères. Chaque duplex peut être branché sur un circuit dédié classé au 10A ou les duplex peuvent être groupés ensemble sur le même circuit que la charge totale des duplex couplées ne dépassant pas le service électrique 10A ils sont câblés.
- H: Cette hotte comporte trois prises électriques supplémentaires, individuellement câblés à la boîte câblées individuellement et classé comme 230V, monophasé, 60 Hz, 10 ampères. Chaque duplex peut être branché sur un circuit dédié classé au 10A ou les duplex peuvent être groupés ensemble sur le même circuit que la charge totale des duplex couplées ne dépassant pas le service électrique 10A ils sont câblés.
- J: Cette hotte comprend quatre autres prises électriques, individuellement câblés à la boîte câblées individuellement et classé comme 230V, monophasé, 60 Hz, 10 ampères. Chaque duplex peut être branché sur un circuit dédié classé au 10A ou les duplex peuvent être groupés ensemble sur le même circuit que la charge totale des duplex couplées ne dépassant pas le service électrique 10A ils sont câblés.
- K: Cette hotte comprend un réceptacle électrique supplémentaire, individuellement raccordés aux boîtiers câblées individuellement et classé comme 230V, monophasé, 50 Hz, 10 ampères. Chaque duplex peut être branché sur un circuit dédié classé au 10A ou les duplex peuvent être groupés ensemble sur le même circuit que la charge totale des duplex couplées ne dépassant pas le service électrique 10A ils sont câblés.
- L: Cette hotte comprend deux autres prises électriques, individuellement câblés à la boîte câblées individuellement et classé comme 230V, monophasé, 50Hz, 10 ampères. Chaque duplex peut être branché sur un circuit dédié classé au 10A ou les duplex peuvent être groupés ensemble sur le même circuit que la charge totale des duplex couplées ne dépassant pas le service électrique 10A ils sont câblés.
- M: Cette hotte comporte trois prises électriques supplémentaires, individuellement câblés à la boîte câblées individuellement et classé

Appendix D: Serial Number Tag Description

comme 230V, monophasé, 50Hz, 10 ampères. Chaque duplex peut être branché sur un circuit dédié classé au 10A ou les duplex peuvent être groupés ensemble sur le même circuit que la charge totale des duplex couplées ne dépassant pas le service électrique 10A ils sont câblés.

- N: Cette hotte comprend quatre autres prises électriques, individuellement câblés à la boîte câblées individuellement et classé comme 230V, monophasé, 50Hz, 10 ampères. Chaque duplex peut être branché sur un circuit dédié classé au 10A ou les duplex peuvent être groupés ensemble sur le même circuit que la charge totale des duplex couplées ne dépassant pas le service électrique 10A ils sont câblés.

APPENDIX E

gGUARD

gGuard Checklist

1. The customer has a PC to install gGuard on that meets the following requirements:
 - Operating system:
 - Windows 7;
 - Windows 7 SP1;
 - Windows Server 2003 SP2;
 - Windows Server 2008;
 - Windows Server 2008 R2;
 - Windows Server 2008 R2 SP1;
 - Windows Vista Service Pack 1;
 - Windows XP SP3
 - Architecture: x86 (32bits) /
 x64 (64bits) / ia64
 - Processor: x86 – 1Gb or more,
 512Mb min x64 – 1,4Gb or more
 - Minimal Disk space:
 - x86 – 850Mb + 5Gb free memory hard disk for the SQL Database
 - x64 – 2Gb + 5Gb free memory hard disk for the SQL Database
 - Graphic Card 32 bits
 - Ethernet Card 10/100/1000 Mbps
 - CD-ROM player
2. The designated customer PC that gGuard is to be installed on has full administrator rights or else the IT onsite must provide administrator rights only for gGuard.

Appendix E: gGuard

Additional information that is needed to configure gGuard on-site

- To set email notification, the user must provide the SMTP server address as well as the port #.
- The IT at the user location assigns an IP address to each filtered fume hood.
- The user designates a username and password for gGuard set up.
- The user provides a name and location for each hood within the gGuard software.
- The user scans the list of email alerts and selects the ones he/she wants to receive.

List of Email Alerts

Level 1

<input checked="" type="checkbox"/> Faulty Electro Sensor	Acid detector out of order
<input checked="" type="checkbox"/> Faulty Heat Sensor	Temperature Detector out of order
<input checked="" type="checkbox"/> Faulty Semicon Sensor	Solvent detector out of order

Level 2

<input checked="" type="checkbox"/> Electro First Detection	Acid Sensor Alarm: Main Neutrodine filter end of life
<input checked="" type="checkbox"/> Electro Sensor Imminent replacement	Acid detector limit usage date is imminent.
<input checked="" type="checkbox"/> Fan regulation failure	Low RPM Speed
<input checked="" type="checkbox"/> Filter Routine Check	NFX 15-211 Neutrodine Filter Routine Check
<input checked="" type="checkbox"/> Sash too open	Sash too open
<input checked="" type="checkbox"/> Semicon First Detection	Solvent Sensor Alarm: Main Neutrodine filter end of life

Level 3

<input checked="" type="checkbox"/> GFH Event History full	Historic file is full.
<input checked="" type="checkbox"/> Temperature > 40°C	Enclosure Temperature exceeded 40°C.
<input checked="" type="checkbox"/> Temperature > 60°C	Critical temperature. Fans stopped
<input checked="" type="checkbox"/> User card removed	User card removed during manipulation

Level 4

<input checked="" type="checkbox"/> Configuration mismatch	Hardware Configuration mismatch.
<input checked="" type="checkbox"/> Electro Second Detection	Acid Sensor Alarm: Replace main Neutrodine filters
<input checked="" type="checkbox"/> Fan out of order	Fan out of order
<input checked="" type="checkbox"/> LP Report predicted filter end of life	LP Report predicted filter end of life alert
<input checked="" type="checkbox"/> Neutrodine lifecycle shelflife exceeded	Neutrodine lifecycle complete.
<input checked="" type="checkbox"/> Replace Electro Sensor	Acid detector must be exchanged.
<input checked="" type="checkbox"/> Semicon Second Detection	Solvent Sensor Alarm: Replace main Neutrodine filters
<input checked="" type="checkbox"/> Unauthorized user card	User Card Not Validated

gGuard Recommendations

To ensure communication, Erlab recommends the following:

- gGuard is installed on a PC provided by the user that is on the same network segment or subnet as the hoods themselves.
- If the user PC is not on the same network segment or subnet then another PC should be installed by the user on the same subnet as the hoods in the lab. Then 3rd party remote desktop software provided by user should be used to view that PC with gGuard installed from others on-site that want to view gGuard on the network.
- The PC that has gGuard is configured to never sleep, standby or hibernate under the power options. This will ensure communication to receive every email alert from software.
- If two or more people would like to receive email alerts then a group email address should be created by the IT on-site for those who want to get email alerts from the gGuard software.
- If there is an internal Firewall, IT on-site allows FTP transmission through the firewall, specifically ports 21 and 23.
- Static IP's should be assigned to each hood by IT on-site.

Appendix E: gGuard

Explanation of gGuard

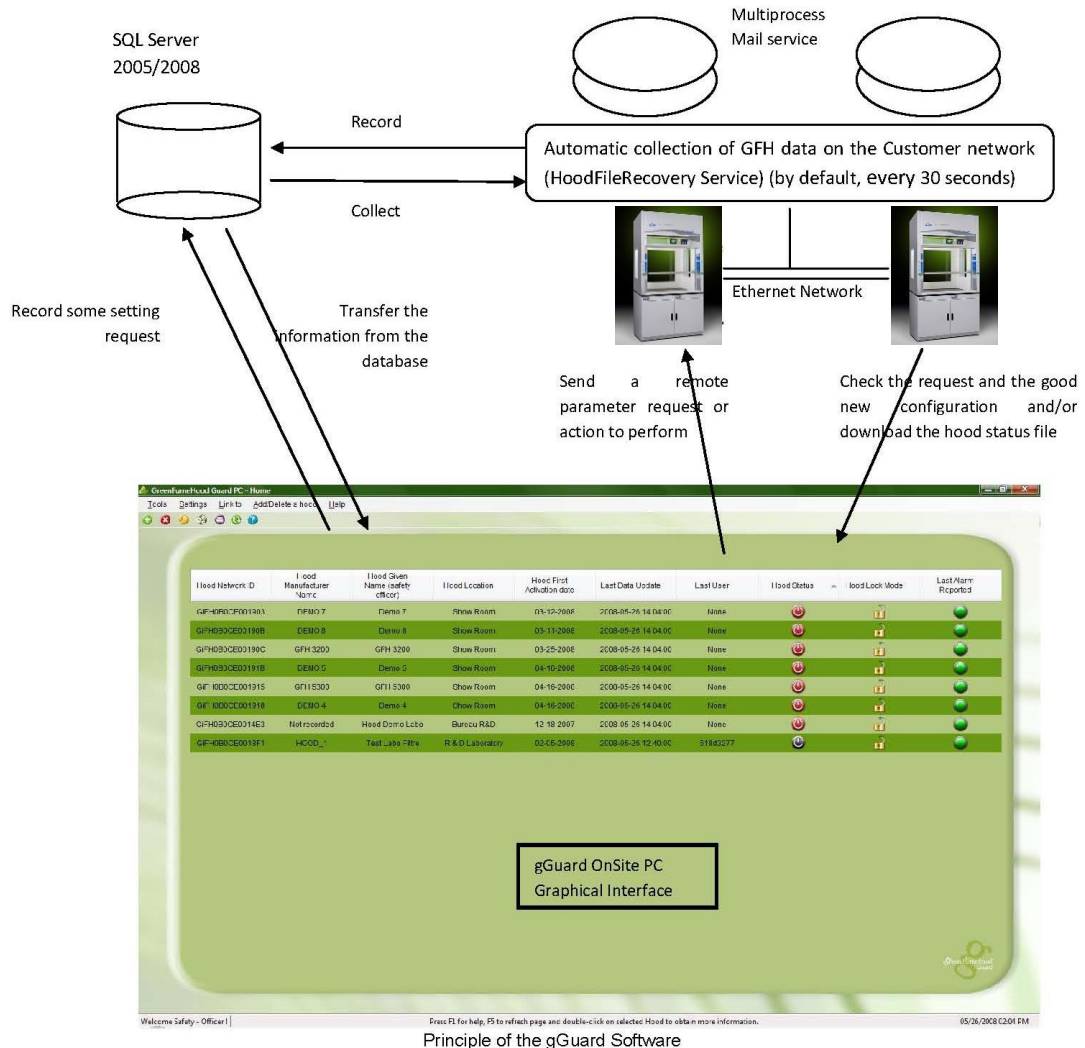

Presentation of the email notification in the gGuard Software

1/ how the communication between the computer (equipped with gGuard) and the GFH works

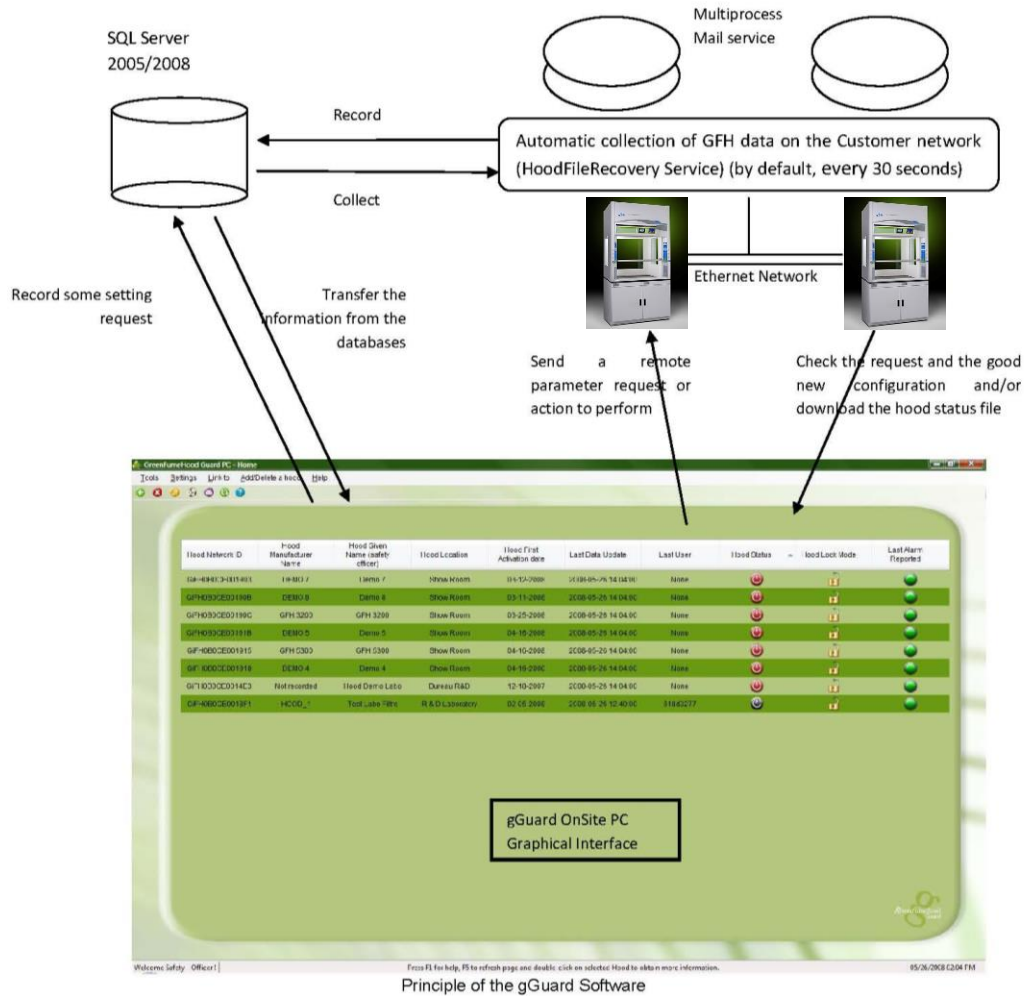

Principle of the gGuard Software

Appendix E: gGuard

2/ Why is the communication not working?

If the computer equipped with the gGuard software is not able to communicate with the GFH, on the main screen of gGuard, you may see red under the Hood Status. If this is the case there is usually one of four reasons why you cannot communicate.

1. You could be having network problems. Ask the IT staff on-site as there could be an outage, upgrade or repair taking place on the network. Please ask your IT representative.
2. The GFH lost its IP address information that was previously entered in the control module. A network device may have caused the GFH to not retain its IP information. At which case you must follow the Check GFH IP information.
3. The FTP server is locked. Your GFH control module acts as a FTP server and your PC with gGuard acts as a client. If some network device prematurely closed the FTP connection before the gGuard software was finished with the session the FTP server can become locked. Follow the FTP server is locked procedure.
4. The network cable became compromised or unplugged from the control unit. Especially if there was any maintenance, or service work done on or around the GFH recently. Please check and reseal all connections.

To assist in determining which one is the problem, try these few things first from your PC.

At the command prompt try and ping the GFH in question that is not communicating on the "home page." Start→Run→CMD→now type ping <space> then the IP address of the hood that is not communicating.

You will see 4 packets sent and 4 packets received if it can communicate. You will see 4 packets sent and 0 received if it cannot communicate.

Based on your results you have one of the following problems. If you can receive the packets from the ping command then the FTP server is locked. It needs to be rebooted to unlock the server and restart communication. Follow the FTP server is locked procedure.

If it cannot receive any packets then you must check the GFH network parameters, the IP address, Subnet Mask, and Gateway. In which case you need to go to the hood with an "administrator" card and follow check the GFH IP information procedure.

Check the GFH IP information

With your Administration Card, in the “hood status” menu of the GFH concerned by this problem, check the IP Address, GW, and Subnet Mask to make sure it equals what you have in gGuard **xxx.xxx.xxx.xxx** and what is on your lab diagram.

If 0's or not correct you must re-enter the IP information from your lab diagram to that specific hoods network parameters.

To do this go to the “Administration Menu” press “OK” to select it.

- Then arrow down to “Network Parameters” press “OK” to select it.
- On “Ethernet” press “OK” to select it.
- Tip here select DHCP “Yes” then “No” to get the subnet mask to partially fill out if you have a static IP address.
- Use the arrow keys to enter the IP information from your lab diagram. Once you are sure it is correct press “OK” to “save and exit.”

Now go back to the PC with gGuard and “double click” on the hood in question. Once the window opens to that hood press “F8” to force an immediate download of the file from the hood.

FTP Server is locked

If the IP information is correct but you still cannot communicate with the hood you must reboot the controller to unlock the FTP server.

To do this:

1. Press the light and fan icon on the controller and wait 30 seconds for it to turn off.
2. On the left side of the controller with the problem, pull out the black fuse cartridge just enough to see the first fuse and break the power connection.
3. Wait 30 seconds and then push it back in. You will see it say “Booting” then come up. Then turn the fans on with the “user” card.
4. After it is on, go to the computer with gGuard and “double click” on the hood in question. Once that window opens press “F8” to force an immediate download of the file from the hood.

Appendix E: gGuard

3/ why am I not able to receive email notification?

As described on the diagram 1, the service called "Hood File Recovery" collects the data from the GFH every 30 seconds.

This service cannot get the information when:

- GFH IP Address is not correct (between the IP Address entered in "network parameters" and the actual IP address on the network for that node) or communication lost (bad connection, router default...).
- If the service is locked by the firewall (FTP access, we use the standard FTP ports 21 and 23 for communication).
- If the hood is in reboot process (which can last 1 minute).
- Only the last alarm event ON is sent by email. That means if 2 alarms are activated at the same time, only the second one sends an email. Also, if the alarm is activated and deactivated up to 30 seconds after the first activation, any alarm notification will not be sent (ex. sash too high but then lowered right away less than 30 seconds will not produce an email).

gGuard Installation

1. Insert disc in CD ROM drive, it should “Auto run.”
2. If it does not “Auto run” then you must go to Start→My Computer→then double click on the CD drive that has the gGuard disc in it.

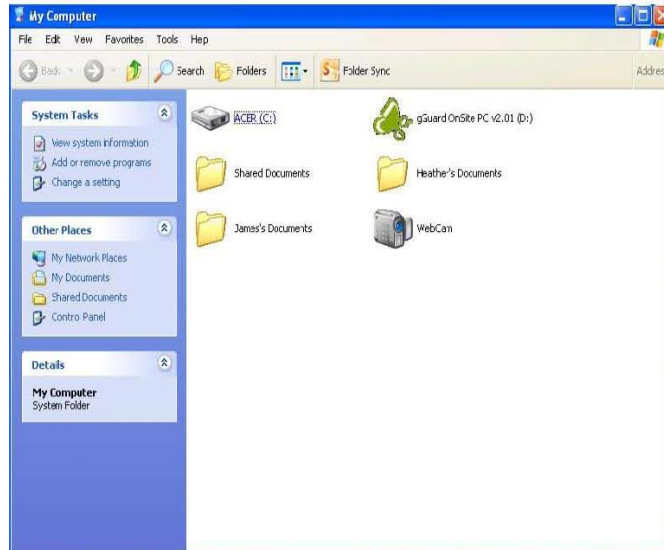

3. It will now start to install, it scans the PC first to look for SQL Server 2005/2008. If that is not found it first asks you to install SQL Server 2005/2008. If this is the case follow the prompts and install it. Then it will resume the install of gGuard.
4. ******Note****** If when it resumes the install of gGuard it seems to take too long you must move the installation window down to reveal the other window that pops up that asks you to restart. You must hit “Ok” and it will then complete the install.
5. It then prompts you to this screen.

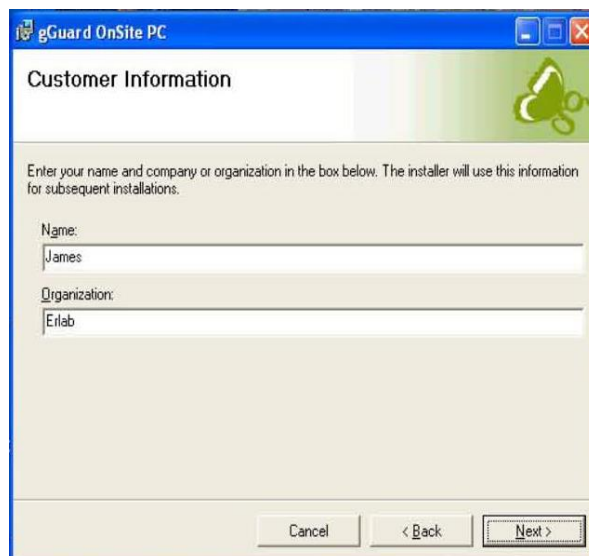

The name usually is the name of the user on the computer or the safety officer.

Under organization you may put the company name.

Appendix E: gGuard

- Next it will show the directory where it will install gGuard on the PC. Just let it install it where it wants, like below. Choose “everyone” and press next.

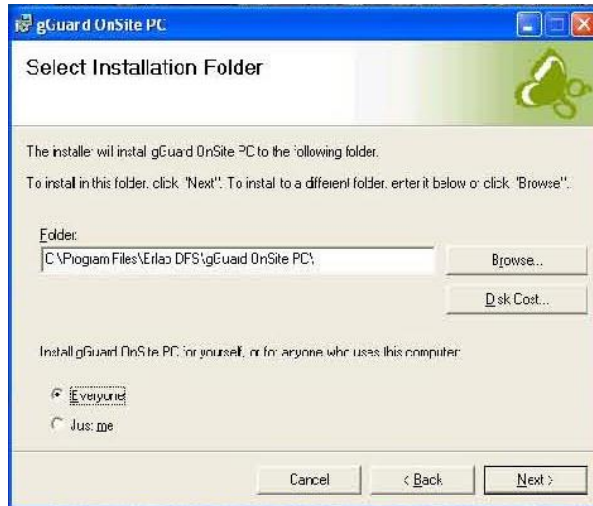

- Then follow the prompts at this screen, press next.

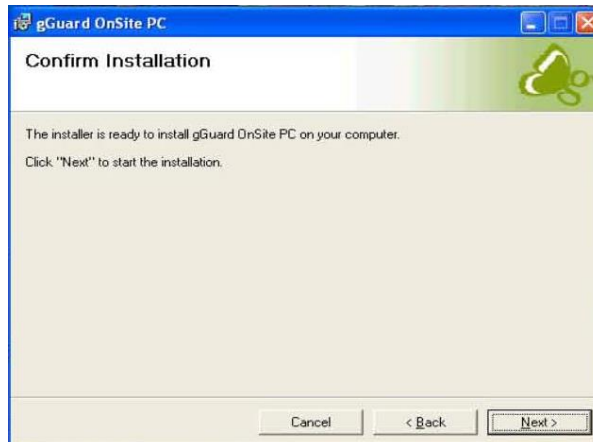

8. As mentioned earlier to warn you, here is the screen to watch for to come up in the task bar because it comes up behind the installation window. If you do not catch the task bar you will not know it is there. Below is the screen shot of the window that comes up behind the installation window asking you to reboot. It has been moved to the front to show you.



9. Then follow the prompts at this screen.

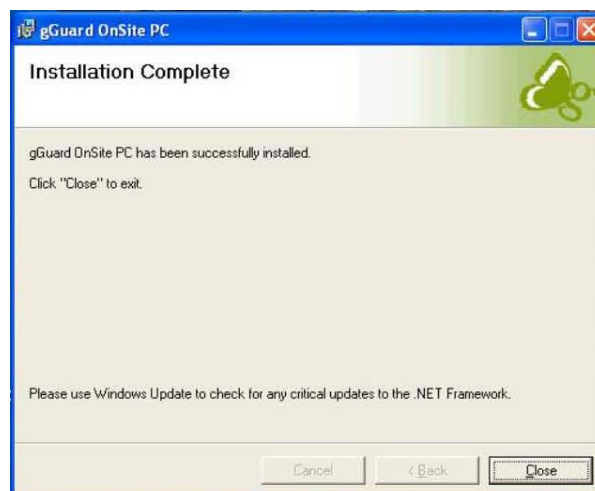

Appendix E: gGuard

10. Next reboot the PC and when it comes up double click on the gGuard icon to open it. You will then see this screen below.

11. Leave the server name as “local host” do not change this. You may fill out the rest; company name, safety officer login, password, confirm password, and finally the safety officer’s email address. Then press “next.”
12. Now you must activate your version of gGuard. Double click on the gGuard icon and log in (using the name and password you set earlier. Then click on Settings→Software settings then enter the serial number that is on the inside cover of the plastic gGuard CD case. Once it is activated you can then add hoods.
13. Click on Add/Delete a hood→Add a hood then enter the IP address of the first hood that you want to add then “connect.” You will see this screen when you press “connect” below.

14. The press “validate” to add it then you will see this below. From this screen you can add all the hoods using the “Add another hood” option, but you will need to remember them when you go back in and name them all at the end. So an easier option is to name them as you add them while still in this screen. You can choose “Hood remote settings.”

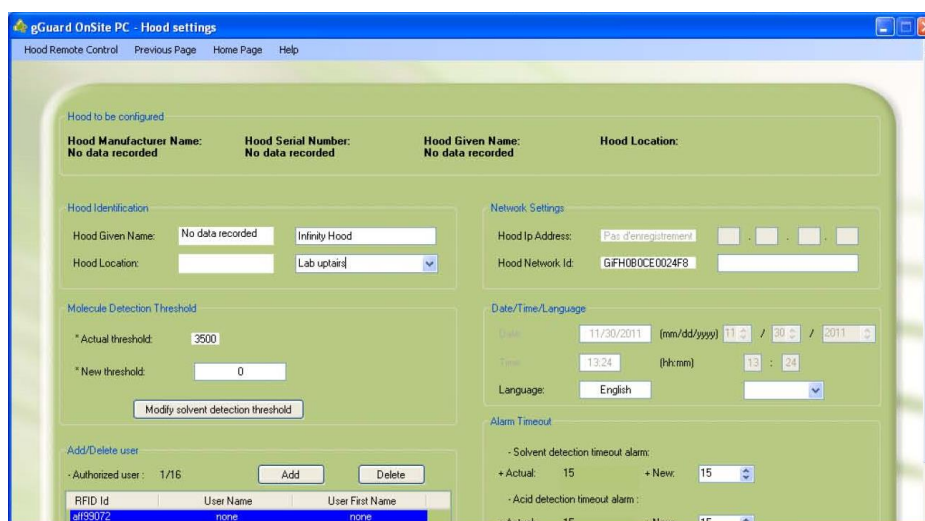
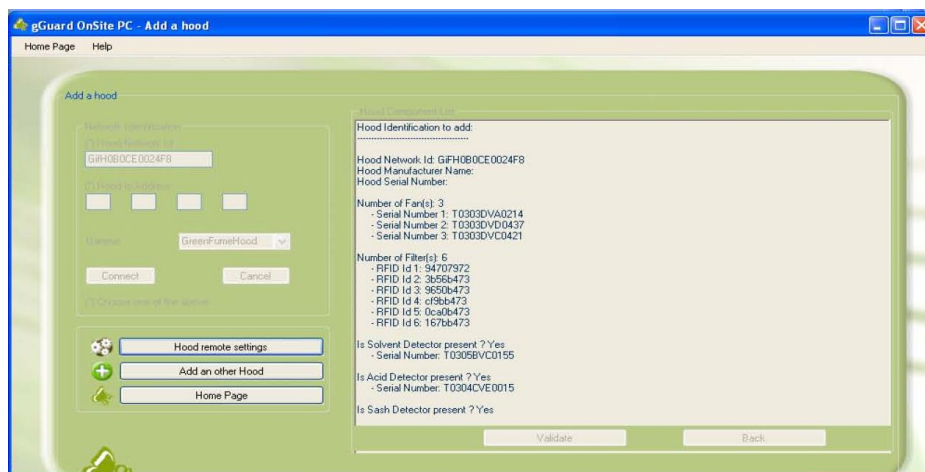

15. Then this screen will open (shown above). In the second column for “Hood Given Name” you may name it here (Infinity Hood) then in the text box below put the room # (Lab upstairs).

Appendix E: gGuard

16. After you name the hood then press “Validate,” then “Confirm chosen configuration,” “OK” to user manipulates hood, “Yes” (as shown below).

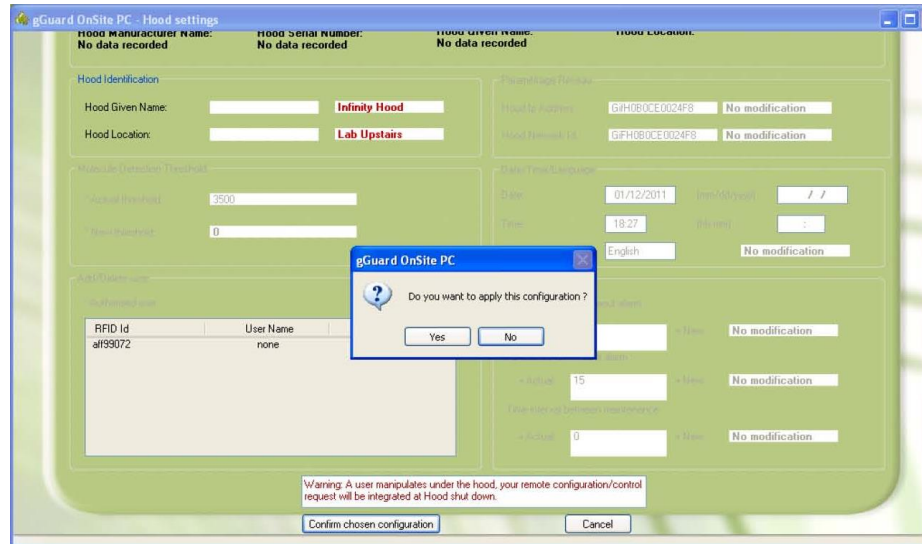

17. Now go back to the “Home Page” → “Add/Delete a hood” → “Add.” Now add the next hood. Repeat this process until all the hoods have been added.

Tip: There are two options for setting up the GFH hoods for connectivity to a network. One is with a “Static IP” the other is “Dynamic IP.” Option one is the most common however, there may be cases (typically one hood installations) that will use option two.

Option 1: “Static IP.” This is the most common option where the onsite IT provides Erlab with the IP address, Subnet Mask, and Default Gateway.

At The Hood

Enter the provided IP, Subnet Mask, and GW.

Go to Administration→Network Parameters→Ethernet→

Set the DHCP “No” then enter the other information.

“Save and Exit.”

At the PC with gGuard

Open gGuard→Add/Delete a Hood→Add→IP

Now enter the IP address of the first hood then→connect.

Option 2: “Dynamic IP.” This option is used when the DHCP and the IP address automatically renews.

At the Hood

Go to Administration→Network Parameters→Ethernet→

Set the DHCP to “Yes.”

“Save and Exit.”

Now get the Mac# of the hood. To do this have the hood turned off but with power.

Remove the card that is in the card holder.

When the screen goes black press “Ok.”

The MAC will be displayed on the screen.

Example GifH0B0CE0024F8

Write it down.

At the PC with gGuard

Open gGuard→Add/Delete a Hood→Add→Network ID (MAC#).

Now enter the Mac address of the first hood then→connect.

(The GifH must be entered exactly as it is case sensitive)

(Follow the instructions shown above)

APPENDIX F

BACNET™

BACnet Checklist

1. Find out what your physical layer device and communication protocol is.
2. Labconco uses the ETH1000. Check the physical layer device and driver with the following spreadsheet:

INDUSTRIAL CONTROL COMMUNICATIONS, INC.

Millennium Series Gateway Family
Supported Drivers List as of April 2, 2012

Physical Layer	Driver	Device	ETH-1000
RS-485	A.O. Smith AIN		✓
	A.O. Smith FDRP		✓
	BACnet MS/TP Client		✓
	BACnet MS/TP Server		✓
	TCS Bays Master		✓
	MSA Chillgard Monitor		✓
	DMX-512 Master		✓
	DMX-512 Slave		✓
	M-Bus Master		✓
	Metasys N2 Master		✓
	Metasys N2 Slave		✓
	Modbus RTU Master		✓
	Modbus RTU Slave		✓
	Modbus RTU Sniffer		✓
	Siemens FLN Slave		✓
	Sullair Master		✓
	Toshiba ASD Master		✓
DeviceNet	DeviceNet Slave		
Profibus	Profibus DP-V1 Slave		
Ethernet	EtherCAT slave		
	BACnet/IP Client		✓
	BACnet/IP Server		✓
	CC-Link IE S1MP Client		✓
	CSP Client		✓
	CSP Server		✓
	EtherNet/IP Client		✓
	EtherNet/IP Server		✓
	MELSEC Client		✓
	MELSEC Server		✓
	Modbus/TCP Client		✓
Modbus/TCP Server		✓	
PROFINET IO Server		✓	

For more information, visit us online at <http://www.iccdesigns.com>.

ICCD
INDUSTRIAL CONTROL COMMUNICATIONS, INC.
1600 Algon Commons, Suite 210
Middleton, WI 53562 USA

Phone: (608) 833-1255
Fax: (608) 833-2045
<http://www.iccdesigns.com>

3. On-site IT should also be consulted and given the above spreadsheet to be sure that the ETH1000 can be integrated into their existing network. Also the most current version can be found on the website which should be referenced at <http://www.iccdesigns.com/downloads/documents/general/Millennium%20Series%20Supported%20Drivers%20List.pdf>

4. The ETH1000 can support up to 10 hoods only. Any number higher than 10 require a second ETH1000. For example 1-10 hoods=1 ETH1000, 15 hoods=2 ETH1000, 20 hoods=2 ETH1000 and 30 hoods=3 ETH1000.
5. You need to order a power supply for the ETH1000 at the time of the initial purchase of the BACnet device. An additional power supply must also be ordered with for every ETH1000 that is needed for the job. The power supply requirements are listed on the ICC website for the ETH1000 and should also be referenced.
6. The ETH1000 can be panel/wall mounted or desktop mounted. It also comes with din rail mounts, if needed. All mounting hardware is included in the kit.
7. Each ETH1000 comes pre-configured with the maximum of 10 GFH. To configure the device on-site IT enters in the IP addresses of the GFH's on-site and deletes all the connections that are not used. Delete all unused GFH connections starting from the last connection first. For example if there were 6 GFH on-site you would then delete 4, which is the unused GFH's starting at the last connection. Also be sure to check "enable" on the GFH client and hit "submit."
8. Labconco provides the BACnet capability of the Protector Hood but it is up to the on-site IT to integrate the ETH1000 into their existing network using the documentation that comes with the device.
9. For all questions regarding the BACnet solution or the Protector Filtered Hood please contact Labconco.

BACnet checklist of additional information that is needed to configure device onsite

- **Unique instance number** that can be used for ETH1000 (per each unit)
- **Unique name** of each ETH1000 (per each unit)
- IP address assigned to the ETH1000 itself (per each unit)
- List of IP addresses for each FGH that is on-site
- List of IP addresses of the GFH's to be assigned to each ETH1000 that is to be installed on-site

Recommendations

Labconco can offer some level of support to the customer to configure ETH1000 but, because of the specific parameters for each location it is the responsibility of the IT on-site to integrate it into their network. This will help ensure that a non-conflicting instance number or name will not be used by each ETH1000 that is installed.

On-site IT should first reference the ETH1000 user's manual as this is the ultimate reference for configuration. All configuration settings are provided in the documentation that comes with the device. Labconco provides the BACnet capability of the GFH but it is up to the IT on-site to configure their BOWs with the data objects they want to see.

*****Labconco is not responsible if IT on-site gives a conflicting instance number or name to the ETH1000 that is used by another device. Labconco is not liable due to improper configuration on-site or lost data from other devices*****

Appendix F: BACnet

Explanation of ETH1000

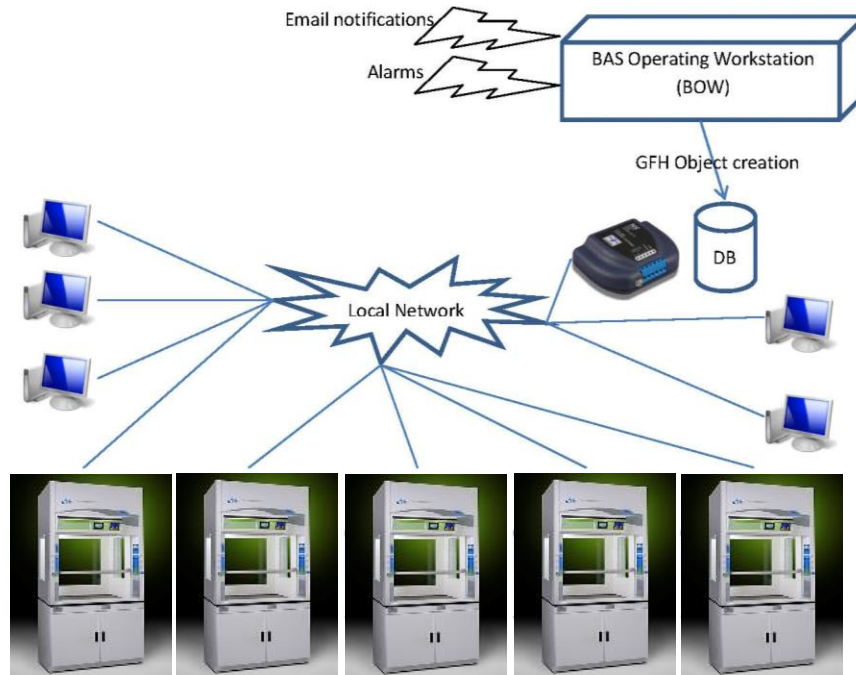

The ICC device (ETH-1000) is connected to the local network with a RJ45 cable as well as the GFH. It collects the data from all GFH from its own memory GFH client (preset by Labconco onsite) and provides the information as objects. A list of objects provided by the device is in the product documentation. These objects can be collected by a BAS Operating Workstation (BOW) according to its own protocol. BOW is then able to generate alarms and email notifications.

APPENDIX G

SECURE MODE

Secure mode can be used so that the hood operator with the “User card” cannot silence any alarms (the sash too high) or turn the hood on/off. They can only turn the lights on/off as it is needed during their hood operation.

Activate Secure Mode

1. Put an “**Administrator**” card in the card reader.
2. Arrow down to “**Administration Menu**” and press “**OK**” to select it.
3. Now arrow down to “**Ventilation**” and press “**OK**” to select it.
4. Next arrow down to “**Secure Mode**” and press “**OK**” to select it.
5. Now press “**OK**” to have it say “**Yes**” then arrow to “**Save and Exit**” and press “**OK**” to save the new setting.

Deactivate Secure Mode

1. Put an “**Administrator**” card in the card reader.
2. Arrow down to “**Administration Menu**” and press “**OK**” to select it.
3. Now arrow down to “**Ventilation**” and press “**OK**” to select it.
4. Next arrow down to “**Secure Mode**” and press “**OK**” to select it.
5. Now press “**OK**” to have it say “**No**” then arrow to “**Save and Exit**” and press “**OK**” to save the new setting.

Appendix G: Secure Mode

How to turn hoods on/off with secure mode activated

There are two ways in which you can turn on/off the hoods when Secure Mode is active either at each hood with an “Administrator” card or through gGuard.

Use Administrator Card turn fans “On”

1. Put an “**Administrator**” card in the card reader.
2. Arrow down to the “**Administrator Menu**” and press “**OK**” to select it.
3. You will now see “**Start fans**” press “**OK**” to start them.
4. You will now see “**Starting fans?**” And press “**OK**” to confirm so they will start.

Use Administrator Card turn fans “Off”

1. Put an “**Administrator**” card in the card reader.
2. Arrow down to the “**Administrator Menu**” and press “**OK**” to select it.
3. You will now see “**Stop fans**” press “**OK**” to start them.
4. You will now see “**Stopping fans?**” And press “**OK**” to confirm so they will stop.

gGuard

Use gGuard to turn fans “On”

1. Open gGuard to the “Home Page” that lists all your hoods.
2. Starting at the top of the list on the page “double click” on the first hood to open a new screen that has all the data for that specific hood.
3. Once the new window opens at the top click on “Hood remote control” to open another window to control the hood.
4. Now look on the lower right of the screen for the “Secure Mode” option.

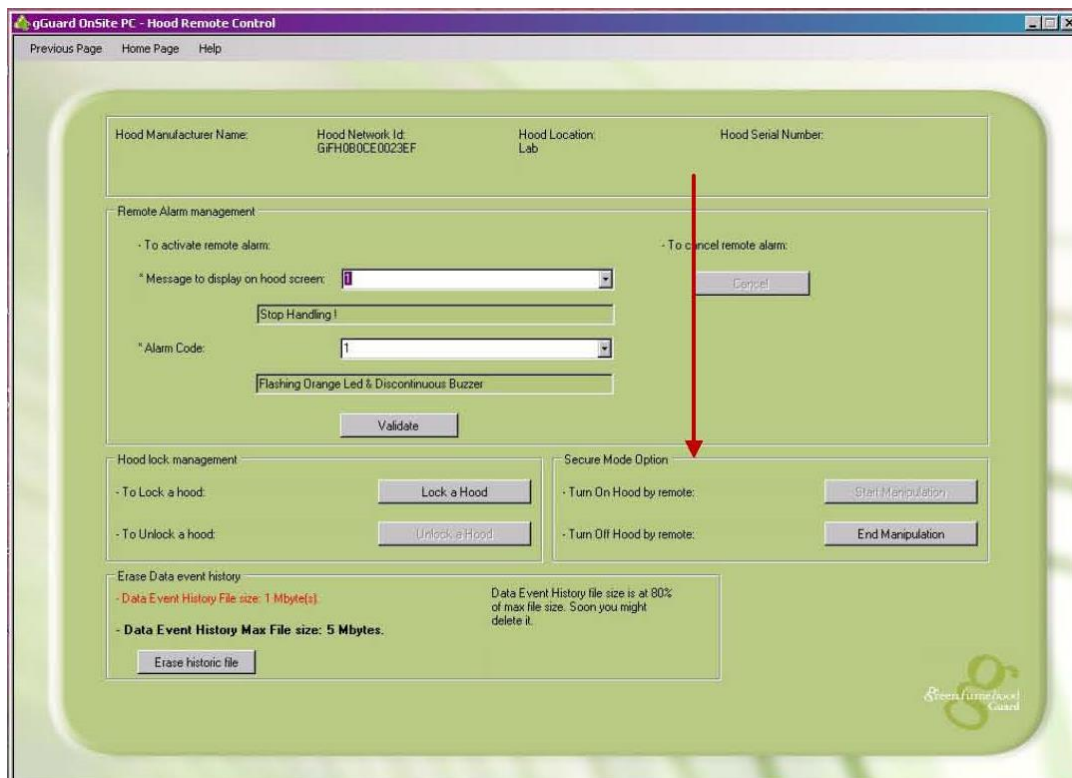

5. Turn “On” the hood by pressing “Start Manipulation” once it is started press the “Home page” at the top.
6. Do this to all the hoods that are on the “Home page” to turn them on.

Appendix G: Secure Mode

Use gGuard to turn fans “Off”

1. Open gGuard to the “Home Page” that lists all your hoods.
2. Starting at the top of the list on the page “double click” on the first hood to open a new screen that has all the data for that specific hood.
3. Once the new window opens at the top click on “Hood remote control” to open another window to control the hood.
4. Now look on the lower right of the screen for the “Secure Mode” option.

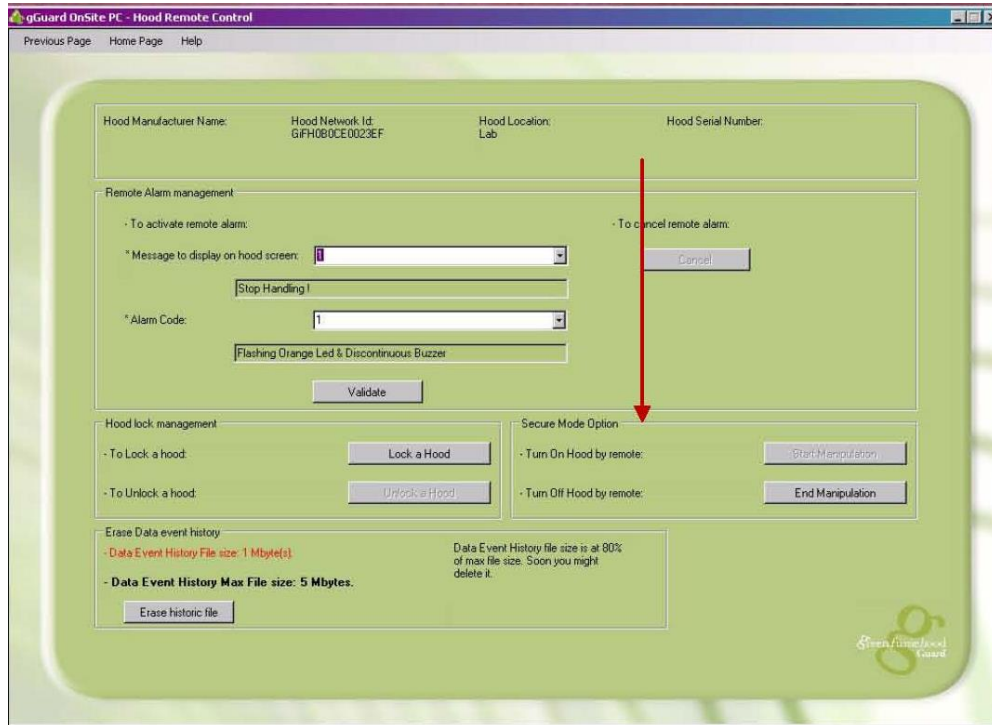

5. Turn “Off” the hood by pressing “End Manipulation” once it is stopped press the “Home page” at the top.
6. Do this to all the hoods that are on the “Home page” to turn them off.

APPENDIX H

CHEMICAL GUIDE

List of approved chemicals for GreenFumeHood® Technology (GFHT) with proprietary Neutrodine® Filtration.

INTRODUCTION

This new edition of the **GreenFumeHood® Chemical Guide 2009** has been developed by **erlab® R&D laboratory**, worldwide leader in filtration technologies for fume hoods.

This guide is the result of 40 years of research and development into filtration technologies and demonstrates the expertise of **erlab's® R&D laboratory** in the field of molecular and particulate filtration.

This booklet is delivered with every fume hood equipped with **GreenFumeHood®** technologies and includes a list of chemicals certified by erlab dfs S.A.S. for handling under the conditions described by the new **AFNOR NF X 15 211:2009 standard**.

Ensure you have the latest copy of this Chemical Guide. Do not hesitate to contact Labconco for the study linked to the Neutrodine® technology lifecycle.

Please contact Labconco/erlab® for information regarding handling of any chemicals which are not listed in this guide.

NEUTRODINE FILTRATION TECHNOLOGY EFFICIENCY TEST CERTIFICATES

All independent tests have been performed by Intertek, a leading provider of product quality certification.

The retention capacities recorded during the tests performed on our filters demonstrate the technical performance developed by Erlab®.

Example of test carried out on a GFH® with:
5 modular columns equipped with Neutrodine® filtration technology.

Isopropanol	Cyclohexane	HCl (35%)
3365 gr	4570 gr	13645 gr

These results ensure the highest protection level to the GFH® users.

Official test report for filtration is available for free download on www.greenfumehood.com

Appendix H: Chemical Guide

NEUTRODINE® FILTRATION TECHNOLOGY PERFORMANCE TESTS PROCEDURE

The Neutrodine® filters are subjected to performance tests conducted according to the requirements described by AFNOR standard NF X 15 211: 2009. The results of the tests given in this guide for the approved chemicals demonstrate the technological performance developed by erlab®.

The apparatus that the tests are performed on was fitted with new filters and installed in a closed space.

The chemical used for the test was evaporated in the fume hood to give a constant concentration during all the operating phases.

The three chemicals selected for the Neutrodine filter performance tests were:

- Isopropanol
- Cyclohexane
- Hydrochloric acid

The concentration of the chemical downstream of the filtration system was checked at least three times an hour during all the filtering fume hood operating phases and was expressed in ppm by volume.

The maximum values of the reference chemicals are given in the list of approved chemicals provided with every Fume Hood equipped with GFH® Technologies.

The test was performed in 8 hour sequences, 16 hours apart.

The Analyzers

Whatever the product being tested, the analysis procedure was adapted so as to obtain a detection threshold of less than 1% of the occupational exposure level or TLV.

The procedure can be one of those described below or any other equivalent method:

- The concentrations of hydrochloric acid in the air were sampled by capturing a known volume of air on a cartridge impregnated with a buffer solution of Na₂CO₃/NaHCO₃. The samples prepared in this way were analyzed by ion chromatography (IC).

- The concentrations of organic gas were sampled by capturing a known volume of air on a cooled cartridge of adsorbent Tenax and active carbon. The samples prepared in this way were analyzed by gas chromatography (GC-FID) after thermal desorption.

The sample prepared in this way was then desorbed by a solution of carbon disulphide (CS₂) before being analyzed using a gas chromatograph (GC) equipped with a suitable detector (FID).

Test procedure

The tests were carried out at (20 ± 2) °C with a relative humidity of between 40% and 70%.

The filtering fume hood being tested was placed in a closed test enclosure with an interior volume of between 10 and 50 times the internal volume of the filtering fume hood.

The difference between the temperature inside the filtering fume hood and the temperature of the test enclosure must not exceed 5°C.

The chemical used for the test was introduced using a peristaltic pump, drop by drop into a heated recipient in the centre of the worktop in the filtering fume hood being tested.

The system was set so as to produce the desired concentration to more or less 10% in the filtering fume hood for the whole duration of the test.

When necessary, the recipient was heated to slightly more than the boiling point of the test chemical in order to ensure instant evaporation.

Diagram of the test assembly (Evaporation and air sampling principle)

The air is sampled in three zones according to a procedure to be adapted according to the measurement protocol adopted:

- Zone 1: During the whole test air is regularly sampled 30cm downstream of the filtering system to check the purifying performance of the filtering fume hood being tested;
- Zone 2: As soon as the test begins, (as soon as the evaporation concentration is stable) the air is sampled inside the fume hood, 30cm upstream of the filtering system to check that the concentration released before the filters has evaporated.

All the necessary precautions must be taken during the test to avoid anything affecting the air samples between the sampling zone and the analyzer. Sampling must be carried out so as to provide a measurement result that is representative of the air analyzed (e.g. by using multipoint sampling grids).

Normal operating phase:

The concentration of the chemical used for the test downstream of the filter must not exceed 1% of the authorized occupational exposure limit. The evaporation must last for the entire quantity of the chemical considered (given in the list of approved chemicals supplied by erlab®)

Detection phase:

Concentration of the chemical used for the test downstream of the filter must not exceed 1% of the authorized occupational exposure limit for class 1 filtering fume hoods and 50% of the authorized occupational exposure limit for class 2 filtering fume hoods.

Safety phase (for class 1 apparatus):

Concentration of the chemical used for the test downstream of the filter must not exceed 50 % of the authorized occupational exposure limit. This phase must not be less than 1/12 of the duration of the normal operating phase.

Filtration test reports:

The test report for each test performed must indicate:

- the reference of the test (name of the laboratory performing the test, date);
- the volume of the test enclosure that the filtering fume hood is placed in;
- the type and reference of the filtering fume hood being tested;
- the type and reference of the filter(s) on the filtering fume hood being tested;
- the nature of the chemical used for the test.

For each phase of the test the report must indicate:

- the duration in hours;
- the chosen weight of chemical;
- the concentration of the chemical used for the test in ppm by volume of air extracted.

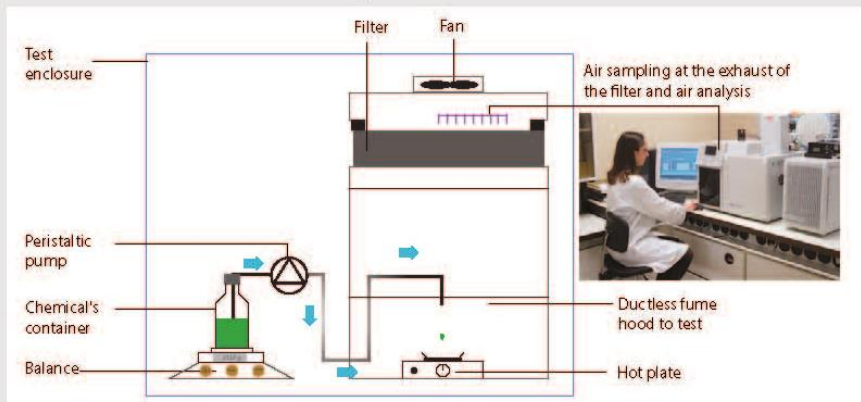

CAUTION

The retention capacities given in this guide only apply to Neutrodine® filtration technology, manufactured and marketed by erlab®.

Occupational Exposure Limits (OEL) or Threshold Limit Values (TLV) are specific to each chemical and under no circumstances may be applied to chemical agents when used in a combination.

Moreover, the values given in this guide may alter in accordance with the latest findings regarding the chemicals included in it:

- OEL or TLV values may be reviewed and corrected by government bodies responsible for establishing them;

- Regulations regarding these chemicals (classification, storage, etc.) are updated in accordance with research and health monitoring authorities;

- Improvement in the performances of Neutrodine filtration technology manufactured by erlab® has a direct effect on retention capacities given in this guide.

The **LP - Pay Back Survey** has been designed to generate data to accurately forecast the life-cycle of the filtration media.

Based on this calculated life-cycle, erlab® forecast the savings of using Neutrodine® Technology versus the energy cost associated with the classic approach of ducting to atmosphere.

LIST OF CHEMICALS NOT RECOMMENDED*

Gaseous chemicals in normal temperature and pressure conditions with a very low boiling point (25°C, 1 Atmosphere).

Examples:

- | | | | |
|-------------------------------|--------------------|----------------------|-------------|
| - Hydrogen (H ₂), | - Ethane, | - Carbon dioxide, | - Propyne, |
| - Helium and noble gases, | - Ethylene oxide, | - Nitrogen monoxide, | - Acetylene |
| - Methane, | - Carbon monoxide, | - Propylene, | |

Organophosphoric compounds :

Because of their very high toxicity (compounds that can be used as Chemical weapons).

Mercury :

In spite of the fact that this product is very well retained by Neutrodine®, it remains extremely toxic (TLV = 0,05 ppm) and very hard to detect.

Hydrogene Cyanide :

Immediately lethal

*Non exhaustive list

DEFINITIONS OF THE COLUMN HEADINGS

Chemical name:

Standard name or brand name of the chemical. For chemical names followed by a ®, the brand names have been registered by their owners.

Formula:

Empirical chemical formula.

C.A.S Number:

Chemical Abstract Number. Unique registration number of the chemical given by the American Chemical Society (ACS).

TLV / OEL

PEL-TWA (OSHA):

Permissible Exposure Level – Time Weighed Average.
American average exposure limit established by the Occupational safety and health administration (OSHA) and expressed in ppm (parts per million). Time-weighted value over 8 hours and 38 or 40 hours per week for 40 working years. These thresholds are most often established with regard to the systemic effects.

PEL-STEL (OSHA):

Permissible Exposure Level – Short term
Exposure Limit. American short term exposure limit established by the Occupational safety and health administration (OSHA) and expressed in ppm (parts per million). 15-minute time weighted value. These threshold values are most often established with regard to systemic effects.

Appendix H: Chemical Guide

THE LONG LIST

Chemical Name	Formula	C.A.S Number	PEL-TWA (OSHA)	PEL-STEL (OSHA)
1, 4-Dioxane	C ₄ H ₈ O ₂	123-91-1	100 ppm	
1,1,1-Trichloroethane	C ₂ H ₃ Cl ₃	71-55-6	350 ppm	
1,1,2,2-Tetrabromoethane	C ₂ H ₂ Br ₄	79-27-6	1 ppm	
1,1,2,2-Tetrachloroethane	C ₂ H ₂ Cl ₄	79-34-5	5 ppm	
1,1,2,2-Tetrachloroethane	C ₂ H ₂ Cl ₄	79-34-5	5 ppm	
1,1'-Biphenyl-4,4'-diamine	C ₈ H ₁₆ N ₂	92-87-5		
1,1-Dichloroethane	C ₂ H ₄ Cl ₂	75-34-3	100 ppm	
1,2-Dibromoethane	C ₂ H ₄ Br ₂	106-93-4	20 ppm	30 ppm
1,2-Dichlorobenzene	C ₆ H ₄ Cl ₂	95-50-1		50 ppm
1,2-Dichloroethane	C ₂ H ₄ Cl ₂	107-06-2	50 ppm	100 ppm
1,2-Dichloroethylene	C ₂ H ₂ Cl ₂	540-59-0	200 ppm	
1,2-Epoxy-3-isopropoxypropane	C ₆ H ₁₂ O ₂	4016-14-2	50 ppm	
1,2-Ethenediol	C ₂ H ₆ O ₂	107-21-1		
1,3-Butadiene	C ₄ H ₆	106-99-0	1 ppm	15 ppm
1,3-Cyclopentadiene	C ₅ H ₆	542-92-7	75 ppm	
1,3-Dichloropropene	C ₃ H ₄ Cl ₂	542-75-6		
1,3-Dichloropropylene	C ₃ H ₄ Cl ₂	542-75-6		
1,3-Dioxolane	C ₃ H ₆ O ₂	646-06-0		
1,3-Divinylbenzene	C ₁₀ H ₁₀	1321-74-0		
1-Aminobutane	C ₄ H ₉ NH ₂	109-73-9		
1-Aminopropane	C ₃ H ₉ NO	107-10-8		
1-Butanethiol	C ₄ H ₁₀ S	109-79-5	10 ppm	
1-Butanethiol	C ₄ H ₁₀ S	109-79-5	10 ppm	
1-Butanol	C ₄ H ₁₀ O	71-36-3	100 ppm	
1-Chloro butane	C ₄ H ₉ Cl	109-69-3		
1-Chloro-2,3-epoxypropane	C ₃ H ₅ ClO	106-89-8	5 ppm	
1-Chloro-2,3-epoxypropane	C ₃ H ₅ ClO	106-89-8	5 ppm	
1-Mercaptobutane	C ₄ H ₁₀ S	109-79-5	10 ppm	
1-Mercaptobutane	C ₄ H ₁₀ S	109-79-5	10 ppm	
1-Mercaptobutane	C ₄ H ₁₀ S	109-79-5	10 ppm	
1-Methyl-2-pyrrolidinone	C ₅ H ₉ NO	872-50-4		
1-Propanethiol	C ₃ H ₈ S	107-03-9		
1-Propanol	C ₃ H ₈ O	71-23-8	200 ppm	
2, 2'-Dichlorodiethyl ether	C ₄ H ₈ OCl ₂	111-44-4		15 ppm
2, 4-Dimethyl pentane	C ₇ H ₁₆	108-08-7		
2,4-Dimethyl-3-pentanone	C ₇ H ₁₄ O	565-80-0		
2,6-Dimethyl-4-heptanone	C ₉ H ₁₈ O	108-83-8	50 ppm	
2-Amino 1-propanol	C ₃ H ₉ NO	35320-23-1		
2-Amino butane	C ₄ H ₉ NH ₂	13952-84-6		
2-Amino pyridine	C ₅ H ₆ N ₂	504-29-0	0,5 ppm	
2-Aminoethanol	C ₂ H ₇ NO	141-43-5	3 ppm	
2-Aminopropane	C ₃ H ₉ N	75-31-0	5 ppm	
2-Butanol	C ₄ H ₁₀ O	78-92-2	150 ppm	
2-Butanone	C ₄ H ₈ O	78-93-3	200 ppm	
2-Butenal	C ₄ H ₆ O	4170-30-3	2 ppm	

Chemical Name	Formula	C.A.S Number	PEL-TWA (OSHA)	PEL-STEL (OSHA)
2-Butoxyethanol	C6H14O2	111-76-2	50 ppm	
2-Chloroacetaldehyde	C2H3OCl	107-20-0		1 ppm
2-Chloroethanal	C2H3OCl	107-20-0		1 ppm
2-Chloroethanol	C2H5OCl	107-07-3	5 ppm	
2-Chloroethyl alcohol	C2H5OCl	107-07-3	5 ppm	
2-Chloropropylene oxide	C3H5OCl	106-89-8	5 ppm	
2-Ethoxy acetate	C6H12O3	111-15-9	100 ppm	
2-Ethoxyethanol	C4H10O2	110-80-5	200 ppm	
2-Ethyl-1-hexanol	C8H18O	104-76-7		
2-Furylmethanol	C5H6O2	98-00-0	50 ppm	
2-Furylmethanol	C5H6O2	98-00-0	50 ppm	
2-Heptanone	C7H14O	110-43-0	100 ppm	
2-Hexanone	C6H12O	591-78-6	100 ppm	
2-Hydroxymethylfuran	C5H6O2	98-00-0	50 ppm	
2-Methyl-1,3-butadiene	C5H8	78-79-5		
2-Methyl-1-propanol	C4H10O	78-83-1	100 ppm	
2-Methylbutane	C5H12	78-78-4		
2-Methylpropyl acetate	C6H12O2	110-19-0	150 ppm	
2-Pentanone	C5H10O	107-87-9	200 ppm	
2-Pentanone	C5H10O	107-87-9	200 ppm	
2-Phenyl propane	C9H12	98-82-8	50 ppm	
2-Propanol	C3H8O	67-63-0	400 ppm	
2-Propanone	C3H6O	67-64-1	1000 ppm	
2-Propen-1-ol	C3H6O	107-18-6	2 ppm	
2-Propenal	C3H4O	107-02-8	0,1 ppm	
2-Propenamide	C3H5NO	79-06-1	0,3 mg/m3	
2-Propenenitrile	C3H3N	107-13-1	2 ppm	10 ppm
2-Propenoic acid	C3H4O2	79-10-7		
2-Propenol	C3H6O	107-18-6	2 ppm	
2-Propyl acetate	C5H10O2	108-21-4	250 ppm	
2-Propylamine	C3H9N	75-31-0	5 ppm	
2-Propyn-1-ol	C3H4O	107-19-7		
2-Propynyl alcohol	C3H4O	107-19-7		
3-Amino-1-propanol	C3H9NO	156-87-6		
3-Chloro-1-propene	C3H5Cl	107-05-1	1 ppm	
3-Cresol	C7H8O	108-39-4		
3-Hydroxytoluene	C7H8O	108-39-4		
3-Methoxy-3-methyl-1-butanol	C6H14O2	56539-66-3		
3-Methyl phenol	C7H8O	108-39-4		
3-Methyl-3-penten-2-one	C6H10O	565-62-8		
3-Octanone	C8H16O	106-68-3		
3-Pentanone	C5H10O	96-22-0		
4,4'-Bianiline	C8H16N2	92-87-5		
4,4'-Biphenyldiamine	C8H16N2	92-87-5		
4,4'-Diaminobiphenyl	C8H16N2	92-87-5		
4-Aminotoluene	C7H9N	106-49-0		
4-Cresol	C7H8O	106-44-5		
4-Hydroxytoluene	C7H8O	106-44-5		

Appendix H: Chemical Guide

Chemical Name	Formula	C.A.S Number	PEL-TWA (OSHA)	PEL-STEL (OSHA)
4-Methyl 2-pentanone	C ₆ H ₁₂ O	108-10-1	100 ppm	
4-Methyl-2-pentanone	C ₆ H ₁₂ O	108-10-1	100 ppm	
4-Methylaniline	C ₇ H ₉ N	106-49-0		
4-tert-Butyl toluene	C ₁₁ H ₁₆	98-51-1	10 ppm	
5-Methyl-3-Heptanone	C ₂ H ₆ O ₂	541-85-5	25 ppm	
Absolute alcohol	C ₂ H ₆ O	64-17-5	1000 ppm	
Acetaldehyde	C ₂ H ₄ O	75-07-0	200 ppm	
Acetic acid	C ₂ H ₄ O ₂	64-19-7	10 ppm	
Acetic anhydre	C ₄ H ₆ O ₃	108-24-7	5 ppm	
Acetic oxide	C ₄ H ₆ O ₃	108-24-7	5 ppm	
Acetone	C ₃ H ₆ O	67-64-1	1000 ppm	
Acetonitrile	C ₂ H ₃ N	75-05-8	40 ppm	
Acetylene	C ₂ H ₂	74-86-2		
Acetylene dichloride	C ₂ H ₂ Cl ₂	540-59-0	200 ppm	
Acetylene tetrabromide	C ₂ H ₂ Br ₄	79-27-6	1 ppm	
Acetylsalilic acid	C ₉ H ₈ O ₄	50-78-2		
a-Chlorotoluene	C ₇ H ₇ Cl	100-44-7	1 ppm	
Acroleic acid	C ₃ H ₄ O ₂	79-10-7		
Acrolein	C ₃ H ₄ O	107-02-8	0,1 ppm	
Acrylamide	C ₃ H ₅ NO	79-06-1	0,3 mg/m ³	
Acrylic acid	C ₃ H ₄ O ₂	79-10-7		
Acrylic aldehyde	C ₃ H ₄ O	107-02-8	0,1 ppm	
Acrylonitrile	C ₃ H ₃ N	107-13-1	2 ppm	10 ppm
Alcohol	C ₂ H ₆ O	64-17-5	1000 ppm	
Allyl alcohol	C ₃ H ₆ O	107-18-6	2 ppm	
Allyl alcohol	C ₃ H ₆ O	107-18-6	2 ppm	
Allyl aldehyde	C ₃ H ₄ O	107-02-8	0,1 ppm	
Allyl chloride	C ₃ H ₅ Cl	107-05-1	1 ppm	
Allylene	C ₃ H ₄	74-99-7	1000 ppm	
Allyglycidylether	C ₆ H ₁₀ O ₂	106-92-3		10 ppm
Alumina	Al ₂ O ₃	1344-28-1		
Aluminium	Al	7429-90-5	15 total dust mg/m ³	
Aluminum oxide	Al ₂ O ₃	1344-28-1		
Aluminum trioxide	Al ₂ O ₃	1344-28-1		
Amino-benzene	C ₆ H ₅ NH ₂	62-53-3	5 ppm	
Aminocyclohexane	C ₆ H ₁₁ NH ₂	108-91-8		
Aminoethane	C ₂ H ₇ N	75-04-7	10 ppm	
Aminomethane	CH ₅ N	74-89-5	10 ppm	
Ammonia	NH ₃	7664-41-7	50 ppm	
Ammonium chloride	NH ₄ Cl	12125-02-9		
Ammonium chloride (fumes)	NH ₄ Cl	12125-02-9		
Ammonium hydroxyde sol	NH ₄ OH	7664-41-7	50 ppm	
Amorphous silica	SiO ₂	7631-86-9	80/ % silica total dust mg/m ³	
Amyl alcohol n	C ₅ H ₁₂ O	71-41-0		
Anhydrous hydrogen bromide	HBr	10035-10-6	3 ppm	
Anhydrous hydrogen bromide	HBr	10035-10-6	3 ppm	
Aniline	C ₆ H ₅ NH ₂	62-53-3	5 ppm	
Aqua fortis	HNO ₃	7697-37-2	2 ppm	

Chemical Name	Formula	C.A.S Number	PEL-TWA (OSHA)	PEL-STEL (OSHA)
Aqua regia	HCL+HNO3			
Aqueous hydrogen bromide (i.e.	HBr	10035-10-6	3 ppm	
Aqueous hydrogen chloride (i.e.	HCl aq. sol.	7647-01-0		5 ppm
Arsenic (inorganic compounds, as As)	As	7440-38-2	0,01 mg/m ³	
Asbestos	Hydrated mineral silicates	1332-21-4		
Aspirin	C9H8O4	50-78-2		
Atrazine	C8H14ClN5	1912-24-9		
Azide	NaN3	26628-22-8		
Azine	C5H5N	110-86-1	5 ppm	
Barium chloride	BaCl2.2H2O	10326-38-9		
Benzenamine	C6H5NH2	62-53-3	5 ppm	
Benzene	C6H6	71-43-2	1 ppm	5 ppm
Benzene chloride	C6H5Cl	108-90-7	75 ppm	
Benzene chloride	C6H5Cl	108-90-7	75 ppm	
Benzine 35 80	C8H16N2	92-87-5		
Benzyl alcohol	C6H5CH2OH	100-51-6		
Benzyl chloride	C7H7Cl	100-44-7	1 ppm	
Beryllium compounds (as Be)	Be	7440-41-7	0,002 mg/m ³	0,005 mg/m ³
BET	C21H20N3Br	1239-45-8		
beta-Aminoethyl alcohol	C2H7NO	141-43-5	3 ppm	
beta-Chloroprene	C4H4Cl	126-99-8	25 ppm	
beta-Methyl acrolein	C4H6O	4170-30-3	2 ppm	
beta-Methylpropyl ethanoate	C6H12O2	110-19-0	150 ppm	
Bicyclopentadiene	C10H12	77-73-6		
Biotite	K(Mg, Fe)3AlSi3O10(F, OH)2	12001-26-2	20 mppcf ppm	
Borax	Na2B4O7 • 10H2O	1303-96-4		
Boron oxide	B2O3	1303-86-2	15 total dust mg/m ³	
Bromine	Br2	7726-95-6	0,1 ppm	
Bromochloromethane	CH2BrCl	74-97-5	200 ppm	
Bromoethane	C2H5Br	74-96-4	200 ppm	
Bromoethene	C2H3Br	593-60-2		
Bromoethylene	C2H3Br	593-60-2		
Bromoform	CHBr3	75-25-2	0,5 ppm	
Butanoic acid	C4H8O2	107-92-6		
Butyl acrylate	C7H12O2	141-32-2		
Butyl alcohol	C4H10O	71-36-3	100 ppm	
Butyl alcohol sec	C4H10O	78-92-2	150 ppm	
Butyl alcohol sec	C4H10O	78-92-2	150 ppm	
Butyl alcohol ter	C4H10O	75-65-0	100 ppm	
Butyl alcohol ter	CH2O2	75-12-7		
Butyl carbinol	C5H12O	71-41-0		
Butyl Cellosolve®	C6H14O2	111-76-2	50 ppm	
Butyl ether	C8H18O	142-96-1		
Butyl glycidyl ether	C7H14O2	2426-08-6	50 ppm	
Butyl glycol	C6H14O2	111-76-2	50 ppm	
Butyl lactate	C7H14O3	138-22-7		
Butyl metacrylate	C18H14O2	97-88-1		
Butyl vinyl ether	C6H12O	111-34-2		

Appendix H: Chemical Guide

Chemical Name	Formula	C.A.S Number	PEL-TWA (OSHA)	PEL-STEL (OSHA)
Butyl vinyl ether	C ₆ H ₁₂ O	111-34-2		
Butyric acid	C ₄ H ₈ O ₂	107-92-6		
BVE	C ₆ H ₁₂ O	111-34-2		
Cadmium	Cd	7440-43-9	0,005 mg/m ³	
Cadmium (dust and fumes)	Cd	7440-43-9	0,005 mg/m ³	
Calcium carbonate	CaCO ₃	1317-65-3	15 total dust mg/m ³	
Calcium hydroxide	Ca(OH) ₂	1305-62-0	15 inhalable aerosol mg/m ³	
Calcium hydroxide	Ca(OH) ₂	1305-62-0	15 inhalable aerosol mg/m ³	
Calcium oxide	CaO	1305-78-8	5 mg/m ³	
Calcium sulfate	Ca(SO ₄).2H ₂ O	7778-18-9	15 total dust mg/m ³	
Carbon bromide	CBr ₄	558-13-4		
Carbon disulfide	CS ₂	75-15-0	20 ppm	30 ppm
Carbon tetrabromide	CBr ₄	558-13-4		
Carbon tetrachloride	CCl ₄	56-23-5	10 ppm	25 ppm
Caustic soda	NaOH	1310-73-2	2 mg/m ³	
Cellosolve "Acetate"	C ₆ H ₁₂ O ₃	111-15-9	100 ppm	
Cellosolve®	C ₄ H ₁₀ O ₂	110-80-5	200 ppm	
Cellulose	(C ₆ H ₁₀ O ₅) _n	9004-34-6	15 total dust mg/m ³	
Chlorine	Cl ₂	7782-50-5		1 ppm
Chlorine dioxide	ClO ₂	10049-04-4	0,1 ppm	
Chlorine oxide	ClO ₂	10049-04-4	0,1 ppm	
Chloro-1-nitropropane I	C ₃ H ₆ NO ₂ Cl	600-25-9	20 ppm	
Chlorobromomethane	CH ₂ BrCl	74-97-5	200 ppm	
Chlorobutadiene	C ₄ H ₄ Cl	126-99-8	25 ppm	
Chloroethane	C ₂ H ₅ Cl	75-00-3	1000 ppm	
Chloroethene	C ₂ H ₃ Cl	75-01-4	1 ppm	5 ppm
Chloroethylene	C ₂ H ₃ Cl	75-01-4	1 ppm	5 ppm
Chloroform	CHCl ₃	67-66-3		50 ppm
Chloromethane	CH ₃ Cl	74-87-3	100 ppm	200 ppm
Chloroprene	C ₄ H ₄ Cl	126-99-8	25 ppm	
Chlorothene	C ₂ H ₃ Cl ₃	71-55-6	350 ppm	
Chromic acid	CrO ₃	1333-82-0		
Chromic oxide	CrO ₃	1333-82-0		
Chromium(VI) oxide (1:3)	CrO ₃	1333-82-0		
Cinamene	C ₈ H ₈	100-42-5	100 ppm	200 ppm
Clay	Al ₂ Si ₂ O ₅ (OH) ₄	1332-58-7	15 total dust mg/m ³	
Copper (dusts and mists, as Cu)	Cu	7440-50-8	1 mg/m ³	
Copper oxide (II)	CuO	1317-38-0		
Cresol all isomers	C ₇ H ₈ O	1319-77-3	5 ppm	
Crotonaldehyde	C ₄ H ₆ O	4170-30-3	2 ppm	
Cumene	C ₉ H ₁₂	98-82-8	50 ppm	
Cumol	C ₉ H ₁₂	98-82-8	50 ppm	
Cyanomethane	C ₂ H ₃ N	75-05-8	40 ppm	
Cyclohexane	C ₆ H ₁₂	110-82-7	300 ppm	
Cyclohexanol	C ₆ H ₁₂ O	108-93-0	50 ppm	
Cyclohexanone	C ₆ H ₁₀ O	108-94-1	50 ppm	
Cyclohexene	C ₆ H ₁₀	110-83-8	300 ppm	
Cyclohexyl alcohol	C ₆ H ₁₂ O	108-93-0	50 ppm	

Chemical Name	Formula	C.A.S Number	PEL-TWA (OSHA)	PEL-STEL (OSHA)
Cyclohexyl ketone	C ₆ H ₁₀ O	108-94-1	50 ppm	
Cyclohexylamine	C ₆ H ₁₁ NH ₂	108-91-8		
Cyclopentane	C ₅ H ₁₀	287-92-3		
DEA	C ₄ H ₁₁ NO ₂	111-42-2		
Decane	C ₁₀ H ₂₂	124-18-5		
Diacetone	C ₆ H ₁₂ O ₂	123-42-2	50 ppm	
Diacetone alcohol	C ₆ H ₁₂ O ₂	123-42-2	50 ppm	
Diamine	N ₂ H ₄	302-01-2	1 ppm	
Dibutyl ether	C ₈ H ₁₈ O	142-96-1		
Dichloromethane	CH ₂ Cl ₂	75-09-2	25 ppm	125 ppm
Dichloropropane 1, 2	C ₃ H ₆ Cl ₂	78-87-5	75 ppm	
Dicyclopentadiene	C ₁₀ H ₁₂	77-73-6		
Diethamine	C ₄ H ₁₁ N	109-89-7	25 ppm	
Diethanolamine	C ₄ H ₁₁ NO ₂	111-42-2		
Diethyl ether	C ₄ H ₁₀ O	60-29-7	400 ppm	
Diethyl ketone	C ₅ H ₁₀ O	96-22-0		
Diethyl oxide	C ₄ H ₁₀ O	60-29-7	400 ppm	
Diethylamine	C ₄ H ₁₁ N	109-89-7	25 ppm	
Diethylaminoethanol-2	C ₆ H ₁₅ NO	100-37-8	10 ppm	
Diethylene dioxide	C ₄ H ₈ O ₂	123-91-1	100 ppm	
Diethylene glycol monobutyl ether	C ₈ H ₁₈ O ₃	112-34-5		
Diethylene oxide	C ₄ H ₈ O	109-99-9	200 ppm	
Diethylene triamine	C ₄ H ₁₃ N ₃	111-40-0		
Diisopropyl ether	C ₆ H ₁₄ O	108-20-3	500 ppm	
Diisopropyl ketone	C ₉ H ₁₈ O	108-83-8	50 ppm	
Diisopropyl ketone	C ₇ H ₁₄ O	565-80-0		
Diisopropyl oxide	C ₆ H ₁₄ O	108-20-3	500 ppm	
Diisopropylamine	C ₆ H ₁₅ N	108-18-9	5 ppm	
Dimethoxymethane	C ₃ H ₈ O ₂	109-87-5	1000 ppm	
Dimethyl amine	C ₂ H ₇ N	124-40-3	10 ppm	
Dimethyl benzene (and isomers)	C ₈ H ₁₀	95-47-6	100 ppm	
Dimethyl carbinol	C ₃ H ₈ O	67-63-0	400 ppm	
Dimethyl ether	C ₂ H ₆ O	115-10-6		
Dimethyl ketone	C ₃ H ₆ O	67-64-1	1000 ppm	
Dimethyl sulfoxide	C ₂ H ₆ SO	67-68-5		
Dimethylacetone	C ₅ H ₁₀ O	96-22-0		
Dimethylformamide	C ₃ H ₇ NO	68-12-2	10 ppm	
Dimethylmethane	C ₃ H ₈	74-98-6	1000 ppm	
Diphenyl oxide	C ₁₂ H ₁₀ O	101-84-8	1 ppm	
Dipropyl ketone	C ₇ H ₁₄ O	123-19-3		
Dipropylmethane	C ₇ H ₁₆	142-82-5	500 ppm	
Diuron	C ₉ H ₁₀ Cl ₂ N ₂ O	330-54-1		
Divinyl	C ₄ H ₆	106-99-0	1 ppm	15 ppm
DMA	C ₂ H ₇ N	124-40-3	10 ppm	
DMF	C ₃ H ₇ NO	68-12-2	10 ppm	
DMSO	C ₂ H ₆ SO	67-68-5		
EAK	C ₈ H ₁₆ O	106-68-3		
Epoxy-2,3-propanol-I	C ₃ H ₆ O ₂	556-52-5	50 ppm	

Appendix H: Chemical Guide

Chemical Name	Formula	C.A.S Number	PEL-TWA (OSHA)	PEL-STEL (OSHA)
Erythrene	C ₄ H ₆	106-99-0	1 ppm	15 ppm
Essence of mirbane	C ₆ H ₅ NO ₂	98-95-3	1 ppm	
Ethanal	CH ₂ O	50-00-0	0,75 ppm	2 ppm
Ethanal	C ₂ H ₄ O	75-07-0	200 ppm	
Ethanedioic acid	C ₂ H ₂ O ₄	144-62-7	1 mg/m ³	
Ethanoic acid	C ₂ H ₄ O ₂	64-19-7	10 ppm	
Ethanol	C ₂ H ₆ O	64-17-5	1000 ppm	
Ethanolamine	C ₂ H ₇ NO	141-43-5	3 ppm	
Ethene	C ₂ H ₂	74-86-2		
Ether	C ₄ H ₁₀ O	60-29-7	400 ppm	
Ethidium bromide	C ₂₁ H ₂₀ N ₃ Br	1239-45-8		
Ethyl acetate	C ₄ H ₈ O ₂	141-78-6	400 ppm	
Ethyl acrylate	C ₅ H ₈ O ₂	140-88-5	25 ppm	
Ethyl alcohol	C ₂ H ₆ O	64-17-5	1000 ppm	
ethyl aldehyde	C ₂ H ₄ O	75-07-0	200 ppm	
Ethyl benzene	C ₈ H ₁₀	100-41-4	100 ppm	
Ethyl bromide	C ₂ H ₅ Br	74-96-4	200 ppm	
Ethyl chloride	C ₂ H ₅ Cl	75-00-3	1000 ppm	
ethyl cyanoacrylate	C ₆ H ₇ NO ₂			
Ethyl ethanoate	C ₄ H ₈ O ₂	141-78-6	400 ppm	
Ethyl ether	C ₄ H ₁₀ O	60-29-7	400 ppm	
Ethyl formate	C ₃ H ₆ O ₂	109-94-4	100 ppm	
Ethyl ketone	C ₅ H ₁₀ O	96-22-0		
Ethyl methyl ketone	C ₄ H ₈ O	78-93-3	200 ppm	
Ethyl nitrile	C ₂ H ₃ N	75-05-8	40 ppm	
Ethyl oxide	C ₄ H ₁₀ O	60-29-7	400 ppm	
Ethylamine	C ₂ H ₇ N	75-04-7	10 ppm	
Ethylamyl ketone	C ₈ H ₁₆ O	106-68-3		
Ethylen chlorhydrin	C ₂ H ₅ OCl	107-07-3	5 ppm	
Ethylene alcohol	C ₂ H ₆ O ₂	107-21-1		
Ethylene chloride	C ₂ H ₄ Cl ₂	107-06-2	50 ppm	100 ppm
Ethylene chlorohydrin	C ₂ H ₅ OCl	107-07-3	5 ppm	
Ethylene diamine (solution)	C ₂ H ₈ N ₂	107-15-3	10 ppm	
Ethylene dibromide	C ₂ H ₄ Br ₂	106-93-4	20 ppm	30 ppm
Ethylene dibromide	C ₂ H ₄ Br ₂	106-93-4	20 ppm	30 ppm
Ethylene dichloride	C ₂ H ₄ Cl ₂	107-06-2	50 ppm	100 ppm
Ethylene glycol	C ₂ H ₆ O ₂	107-21-1		
Ethylene glycol mono ethyl ether	C ₄ H ₁₀ O ₂	110-80-5	200 ppm	
Ethylene glycol mono ethyl ether acetate	C ₆ H ₁₂ O ₃	111-15-9	100 ppm	
Ethylene trichloride	C ₂ HCl ₃	79-01-6	100 ppm	200 ppm
Ethylenediamine	C ₂ H ₈ N ₂	107-15-3	10 ppm	
Ethylidene chloride	C ₂ H ₄ Cl ₂	75-34-3	100 ppm	
Ethyne	C ₂ H ₂	74-86-2		
Ferric oxide	Fe ₂ O ₃	1309-37-1	10 mg/m ³	
Forene	C ₃ H ₂ F ₅ ClO			
Formaldehyde	CH ₂ O	50-00-0	0,75 ppm	2 ppm
Formaldehyde solution	CH ₂ O	50-00-0	0,75 ppm	2 ppm
Formalin (as formaldehyde)	CH ₂ O	50-00-0	0,75 ppm	2 ppm

Chemical Name	Formula	C.A.S Number	PEL-TWA (OSHA)	PEL-STEL (OSHA)
Formic acid	CH ₂ O ₂	64-18-6	5 ppm	
Formic aldehyde	CH ₂ O	50-00-0	0,75 ppm	2 ppm
Formonitrile	HCN	74-90-8	10 ppm	
Furfuryl alcohol	C ₅ H ₆ O ₂	98-00-0	50 ppm	
Gasoline 60		8006-61-9		
Glacial acetic acid (pure compound)	C ₂ H ₄ O ₂	64-19-7	10 ppm	
Glucose	C ₆ H ₁₂ O ₆	5996-10-1		
Glutaraldehyde	C ₅ H ₈ O ₂	111-30-8		
Glycerol	C ₃ H ₈ O ₃	56-81-5	15 inhalable dust mg/m ³	
Glycide	C ₃ H ₆ O ₂	556-52-5	50 ppm	
Glycidol	C ₃ H ₆ O ₂	556-52-5	50 ppm	
Glycol	C ₂ H ₆ O ₂	107-21-1		
Graphite (synthetic)	C	7440-44-0		
Halothane	C ₂ HBrClF ₃	151-67-7		
Heptan-4-one	C ₇ H ₁₄ O	123-19-3		
Heptane	C ₇ H ₁₆	142-82-5	500 ppm	
Hexane	C ₆ H ₁₄	110-54-3	500 ppm	
Hexone	C ₆ H ₁₂ O	108-10-1	100 ppm	
Hydrazine	N ₂ H ₄	302-01-2	1 ppm	
Hydrobromic acid	HBr	10035-10-6	3 ppm	
Hydrochloric acid	HCl aq. sol.	7647-01-0		5 ppm
Hydrocyanic acid	HCN	74-90-8	10 ppm	
Hydrofluoric acid	HF aq. sol.	7664-39-3	3 ppm	
Hydrogen chloride	HCl	7647-01-0		5 ppm
Hydrogen cyanide	HCN	74-90-8	10 ppm	
Hydrogen fluoride	HF	7664-39-3	3 ppm	
Hydrogen nitrate	HNO ₃	7697-37-2	2 ppm	
Hydrogen peroxide	H ₂ O ₂	7722-84-1	1 ppm	
Hydrogen peroxide	H ₂ O ₂	7722-84-1	1 ppm	
Hydrogen sulfate	H ₂ SO ₄	7664-93-9	1 mg/m ³	
Hydrogen sulfide	H ₂ S	7783-06-4	4 ppm	20 ppm
Hydroquinone	C ₆ H ₆ O ₂	123-31-9	2 mg/m ³	
Hydroxybenzene	C ₆ H ₆ O	108-95-2	5 ppm	
Hydroxycellulose	(C ₆ H ₁₀ O ₅) _n	9004-34-6	15 total dust mg/m ³	
Hydroxycyclohexane	C ₆ H ₁₂ O	108-93-0	50 ppm	
Hypochlorous acid	HClO			
Iodine	I ₂	7553-56-2		0,1 ppm
Iodoform	CHI ₃	75-47-8		
IPA	C ₃ H ₈ O	67-63-0	400 ppm	
Iron oxide dust and fume (as Fe)	Fe ₂ O ₃	1309-37-1	10 mg/m ³	
Isoamyl acetate	C ₇ H ₁₄ O ₂	123-92-2	100 ppm	
Isoamyl alcohol	C ₅ H ₁₂ O	71-41-0		
Isoamyl alcohol (primary)	C ₅ H ₁₂ O	123-51-3	100 ppm	
Isobutane	C ₄ H ₁₀	75-28-5		
Isobutanol	C ₄ H ₁₀ O	78-83-1	100 ppm	
Isobutenyl methyl ketone	C ₆ H ₁₀ O	141-79-7	25 ppm	
Isobutyl acetate	C ₆ H ₁₂ O ₂	110-19-0	150 ppm	
Isobutyl alcohol	C ₄ H ₁₀ O	78-83-1	100 ppm	

Appendix H: Chemical Guide

Chemical Name	Formula	C.A.S Number	PEL-TWA (OSHA)	PEL-STEL (OSHA)
Isobutyl carbinol	C5H12O	123-51-3	100 ppm	
Isobutyl methyl carbinol	C6H14O	108-11-2	25 ppm	
Isobutyronone	C7H14O	565-80-0		
Isoflurane	C3H2F5ClO	26675-46-7		
iso-Nitropropane	C3H7NO2	79-46-9	25 ppm	
Isooctane	C8H18	540-84-1		
Isooctanol	C8H18O	104-76-7		
Isooctylalcohol	C8H18O	104-76-7		
Isopentane	C5H12	78-78-4		
Isopentyl acetate	C7H14O2	123-92-2	100 ppm	
Isophorone	C9H14O	78-59-1	25 ppm	
Isoprene	C5H8	78-79-5		
Isopropane	C3H7NO2	79-46-9	25 ppm	
Isopropanol	C3H8O	67-63-0	400 ppm	
Isopropyl acetate	C5H10O2	108-21-4	250 ppm	
Isopropyl alcohol	C3H8O	67-63-0	400 ppm	
Isopropyl benzene	C9H12	98-82-8	50 ppm	
Isopropyl benzene	C9H12	98-82-8	50 ppm	
Isopropyl ether	C6H14O	108-20-3	500 ppm	
Isopropyl glycidyl ether	C6H12O2	4016-14-2	50 ppm	
Isopropylamine	C3H9N	75-31-0	5 ppm	
Isopropylcarbinol	C4H10O	78-83-1	100 ppm	
Isopropylideneacetone	C6H10O	141-79-7	25 ppm	
Korax	C3H6NO2Cl	600-25-9	20 ppm	
Limonene	C10H16	5989-54-8		
Lithium hydride	LiH	7580-67-8	0,025 mg/m3	
Magnesia fume	MgO	1309-48-4	15 total dust mg/m3	
Magnesite	MgCO3	546-93-0	15 total dust mg/m3	
Magnesium oxide	MgO	1309-48-4	15 total dust mg/m3	
Manganese compounds (as Mn)	Mn	7439-96-5		5 mg/m3
Manganese oxide (IV)	MnO2	1317-35-7		
m-Cresol	C7H8O	108-39-4		
MEK	C4H8O	78-93-3	200 ppm	
MEK	C4H8O	78-93-3	200 ppm	
Mercapto-2 Ethanol	C2H6SO	60-24-2		
Mesityl oxide	C6H10O	141-79-7	25 ppm	
Mesitylene	C9H12	108-67-8		
Methacrylic acid	C4H6O2	79-41-4		
Methanal	CH2O	50-00-0	0,75 ppm	2 ppm
Methane tetrabromide	CBr4	558-13-4		
Methanoic acid	CH2O2	64-18-6	5 ppm	
Methanol	CH4O	67-56-1	200 ppm	
Methoxycarbonylethylene	C4H5O2	96-33-3	10 ppm	
Methyl acetate	C3H6O2	79-20-9	200 ppm	
Methyl acetylene	C3H4	74-99-7	1000 ppm	
Methyl Acetylene Propadiene Mix.			1000 ppm	
Methyl alcohol	CH4O	67-56-1	200 ppm	
Methyl benzene	C7H8	108-88-3	200 ppm	300 ppm

Chemical Name	Formula	C.A.S Number	PEL-TWA (OSHA)	PEL-STEL (OSHA)
Methyl butyl ketone	C ₆ H ₁₂ O	591-78-6	100 ppm	
Methyl cellosolve	C ₃ H ₈ O ₂	109-86-4	25 ppm	
Methyl chloride	CH ₃ Cl	74-87-3	100 ppm	200 ppm
Methyl chloroform	C ₂ H ₃ Cl ₃	71-55-6	350 ppm	
Methyl cyanide	C ₂ H ₃ N	75-05-8	40 ppm	
Methyl cyanoacrylate	C ₅ H ₅ NO ₂	137-05-3		
Methyl cyclohexane	C ₇ H ₁₄	108-87-2	500 ppm	
Methyl cyclohexanol	C ₇ H ₁₄ O	25639-42-3	100 ppm	
Methyl cyclohexanone	C ₇ H ₁₂ O	1331-22-2	100 ppm	
Methyl ether	C ₂ H ₆ O	115-10-6		
Methyl ethyl ketone	C ₄ H ₈ O	78-93-3	200 ppm	
Methyl formate	C ₂ H ₄ O ₂	107-31-3	100 ppm	
Methyl isobutenyl ketone	C ₆ H ₁₀ O	141-79-7	25 ppm	
Methyl isobutyl ketone	C ₆ H ₁₂ O	108-10-1	100 ppm	
Methyl methacrylate	C ₅ H ₈ O ₂	80-62-6	100 ppm	
Methyl phenol all isomers	C ₇ H ₈ O	1319-77-3	5 ppm	
Methyl propenoate	C ₄ H ₅ O ₂	96-33-3	10 ppm	
Methyl propyl ketone	C ₅ H ₁₀ O	107-87-9	200 ppm	
Methyl styrene	C ₉ H ₁₀	25013-15-4	100 ppm	
Methyl-2-propane	C ₄ H ₁₀	75-28-5		
Methyl-3-butanol-1	C ₅ H ₁₂ O	123-51-3	100 ppm	
Methyl-3-butanol-1	C ₅ H ₁₂ O	71-41-0		
Methylacrylate	C ₄ H ₅ O ₂	96-33-3	10 ppm	
Methylal	C ₃ H ₈ O ₂	109-87-5	1000 ppm	
Methylamine	CH ₅ N	74-89-5	10 ppm	
methylamyl alcohol	C ₆ H ₁₄ O	108-11-2	25 ppm	
Methylene chloride	CH ₂ Cl ₂	75-09-2	25 ppm	125 ppm
Methylene chlorobromide	CH ₂ BrCl	74-97-5	200 ppm	
Methylene dichloride	CH ₂ Cl ₂	75-09-2	25 ppm	125 ppm
Methylene oxide	CH ₂ O	50-00-0	0,75 ppm	2 ppm
Methylethyl carbinol	C ₄ H ₁₀ O	78-92-2	150 ppm	
Methyl-n-amyl ketone	C ₇ H ₁₄ O	110-43-0	100 ppm	
MIBC	C ₆ H ₁₄ O	108-11-2	25 ppm	
MIBK	C ₆ H ₁₂ O	108-10-1	100 ppm	
Mica	K(Mg, Fe) ₃ AlSi ₃ O ₁₀ (F, OH) ₂	12001-26-2	20 mppcf ppm	
Mirbane oil	C ₆ H ₅ NO ₂	98-95-3	1 ppm	
Muriatic acid	HCl aq. sol.	7647-01-0		5 ppm
Muscovite	K(Mg, Fe) ₃ AlSi ₃ O ₁₀ (F, OH) ₂	12001-26-2	20 mppcf ppm	
N,N-Dimethylethylamine	C ₄ H ₁₁ N	598-56-1		
n-Amyl acetate	C ₇ H ₁₄ O ₂	628-63-7	100 ppm	
n-Amyl acetate	C ₇ H ₁₄ O ₂	123-92-2	100 ppm	
Naphta 30/60	85% Nonane/15% trimethylbenzene	8052-41-3	500 ppm	
Naphthalene	C ₁₀ H ₈	91-20-3	10 ppm	
Naphthalin	C ₁₀ H ₈	91-20-3	10 ppm	
n-Butane	C ₄ H ₁₀	106-97-8		
n-Butanethiol	C ₄ H ₁₀ S	109-79-5	10 ppm	
n-Butanol	C ₄ H ₁₀ O	71-36-3	100 ppm	
n-Butyl acetate	C ₆ H ₁₂ O ₂	123-86-4	150 ppm	

Appendix H: Chemical Guide

Chemical Name	Formula	C.A.S Number	PEL-TWA (OSHA)	PEL-STEL (OSHA)
n-Butyl amine	C ₄ H ₉ NH ₂	109-73-9		
n-Butyl chloride	C ₄ H ₉ Cl	109-69-3		
N-Ethylethanamine	C ₄ H ₁₁ N	109-89-7	25 ppm	
n-Hexane	C ₆ H ₁₄	110-54-3	500 ppm	
Nickel metal and other compounds (as Ni)	Ni	7440-02-0	1 mg/m ³	
Ninhydrine (powder)	C ₉ H ₄ O ₃ ·H ₂ O	485-47-2		
Nitric acid	HNO ₃	7697-37-2	2 ppm	
Nitro benzene	C ₆ H ₅ NO ₂	98-95-3	1 ppm	
Nitroethane	C ₂ H ₅ NO ₂	79-24-3	100 ppm	
Nitromethane	CH ₃ NO ₂	75-52-5	100 ppm	
n-Octane	C ₈ H ₁₈	111-65-9	500 ppm	
Nonane all isomers	C ₉ H ₂₀	111-84-2		
n-Pentane	C ₅ H ₁₂	109-66-0	1000 ppm	
o-Chlorotoluene	C ₇ H ₇ Cl	106-43-4		
Orthophosphoric acid	H ₃ PO ₄	7664-38-2	1 mg/m ³	
o-Toluidine	C ₇ H ₉ N	119-93-7		
Oxalic acid	C ₂ H ₂ O ₄	144-62-7	1 mg/m ³	
o-Xylene	C ₈ H ₁₀	95-47-6	100 ppm	
Paraquat	C ₁₂ H ₁₄ N ₂	4685-14-7	0,5 mg/m ³	
Parathion	C ₁₀ H ₁₄ NO ₅ PS	56-38-2	0,1 mg/m ³	
p-Cresol	C ₇ H ₈ O	106-44-5		
p-Dichlorobenzene	C ₆ H ₄ Cl ₂	106-46-7	75 ppm	
Pentachloroethane	C ₂ H ₅ Cl ₅	76-01-7		
Pentanol I	C ₅ H ₁₂ O	71-41-0		
Pentyl acetate	C ₇ H ₁₄ O ₂	628-63-7	100 ppm	
Perchloric acid	HClO ₄	7601-90-3		
Perchloroethylene	C ₂ Cl ₄	127-18-4	100 ppm	200 ppm
Petroleum ether 30/60		8032-32-4		
Phenol	C ₆ H ₆ O	108-95-2	5 ppm	
Phenyl amine	C ₆ H ₅ NH ₂	62-53-3	5 ppm	
Phenyl chloride	C ₆ H ₅ Cl	108-90-7	75 ppm	
Phenyl ether	C ₁₂ H ₁₀ O	101-84-8	1 ppm	
Phenyl glycidyl ether	C ₉ H ₁₀ O ₂	122-60-1	10 ppm	
Phenyl hydroxide	C ₆ H ₆ O	108-95-2	5 ppm	
Phenylethane	C ₈ H ₁₀	100-41-4	100 ppm	
Phenylethylene	C ₈ H ₈	100-42-5	100 ppm	200 ppm
Phenylmethane	C ₇ H ₈	108-88-3	200 ppm	300 ppm
Phosphoric acid	H ₃ PO ₄	7664-38-2	1 mg/m ³	
Platinum	Pt	7440-06-4		
Potassium hydroxide	KOH	1310-58-3		
Potassium hydroxide	KOH	1310-58-3		
Propanal	C ₃ H ₆ O	123-38-6		
Propane	C ₃ H ₈	74-98-6	1000 ppm	
Propanol-I	C ₃ H ₈ O	71-23-8	200 ppm	
Propanolamine	C ₃ H ₉ NO	107-10-8		
Propargyl alcohol	C ₃ H ₄ O	107-19-7		
Propenenitrile	C ₃ H ₃ N	107-13-1	2 ppm	10 ppm
Propyl acetate	C ₅ H ₁₀ O ₂	109-60-4	200 ppm	

Chemical Name	Formula	C.A.S Number	PEL-TWA (OSHA)	PEL-STEL (OSHA)
Propyl alcohol	C3H8O	71-23-8	200 ppm	
Propyl mercaptan	C3H8S	107-03-9		
Propylacetate	C5H10O2	109-60-4	200 ppm	
Propylamine	C3H9N	107-10-8		
Propylbenzene	C9H12	108-67-8		
Propylene aldehyde	C4H6O	4170-30-3	2 ppm	
Propylene chloride	C3H6Cl2	78-87-5	75 ppm	
Propylene dichloride	C3H6Cl2	78-87-5	75 ppm	
Propylene oxide	C3H6O	75-56-9	100 ppm	
Propyne	C3H4	74-99-7	1000 ppm	
Prussic acid	HCN	74-90-8	10 ppm	
p-Toluidine	C7H9N	106-49-0		
Pyridine	C5H5N	110-86-1	5 ppm	
Pyrocellulose	(C6H10O5) _n	9004-34-6	15 total dust mg/m ³	
Quartz	SiO ₂	14808-60-7	30/(%silica+2) total dust mg/m ³	
Red iron oxide	Fe ₂ O ₃	1309-37-1	10 mg/m ³	
Saccharose	C12H22O11	57-50-1	15 inhalable aerosol mg/m ³	
SBA	C4H10O	78-92-2	150 ppm	
sec-Amyl acetate	C7H14O2	123-92-2	100 ppm	
sec-Butyl amine	C4H9NH2	13952-84-6		
sec-Butyl chloride	C4H9Cl	507-20-0		
Silica gel	SiO ₂	7631-86-9	80/ % silica total dust mg/m ³	
Silicon	Si	7440-21-3	15 total dust mg/m ³	
Silver	Ag	7440-22-4	0,01 mg/m ³	
Soda	NaOH	1310-73-2	2 mg/m ³	
Sodium azide	NaN ₃	26628-22-8		
Sodium bisulphite	HNaO ₃ S	7631-90-5		
Sodium hydrate	NaOH	1310-73-2	2 mg/m ³	
Stoddard solvent	85% Nonane/ 15% trimethylbenzene	8052-41-3	500 ppm	
Strychnine	C21H22N2O2	57-24-9	0,15 mg/m ³	
Styrene	C8H8	100-42-5	100 ppm	200 ppm
Sulfur dioxide	SO ₂	7446-09-5	5 ppm	
Sulfuric acid	H ₂ SO ₄	7664-93-9	1 mg/m ³	
ter-Butanol	C4H10O	75-65-0	100 ppm	
ter-Butyl acetate	C6H12O2	540-88-5	200 ppm	
ter-Butyl alcohol	C4H10O	75-65-0	100 ppm	
tert-Butyl alcohol	C4H10O	75-65-0	100 ppm	
Tetrabromomethane	CBr ₄	558-13-4		
Tetrachloroethylene	C2Cl ₄	127-18-4	100 ppm	200 ppm
Tetrachloromethane	CCl ₄	56-23-5	10 ppm	25 ppm
Tetrahydrofuran	C ₄ H ₈ O	109-99-9	200 ppm	
TFA	C ₂ HF ₃ O ₂	76-05-1		
THF	C ₄ H ₈ O	109-99-9	200 ppm	
Tin (inorganic compounds, as Sn)	Sn	7440-31-5		
Tin(IV) oxide (as Sn)	O ₂ Sn	18282-10-5		
Titanium dioxide	TiO ₂	13463-67-7	15 total dust mg/m ³	
TMA	C ₃ H ₉ N	75-50-3		
Toluene	C ₇ H ₈	108-88-3	200 ppm	300 ppm

Appendix H: Chemical Guide

Chemical Name	Formula	C.A.S Number	PEL-TWA (OSHA)	PEL-STEL (OSHA)
Toluol	C7H8	108-88-3	200 ppm	300 ppm
Tribromomethane	CHBr3	75-25-2	0,5 ppm	
Trichloroacetic acid	C2HCl3O2	76-03-9		
Trichloroethane-1,1,2	C2H3Cl3	79-00-5	10 ppm	
Trichloroethanoic acid	C2HCl3O2	76-03-9		
Trichloroethanoic acid	C2HCl3O2	76-03-9		
Trichloroethene	C2HCl3	79-01-6	100 ppm	200 ppm
Trichloroethylene	C2HCl3	79-01-6	100 ppm	200 ppm
Trichloromethane	CHCl3	67-66-3		50 ppm
Triethylamine	C6H15N	121-44-8	25 ppm	
Trifluoroacetic acid	C2HF3O2	76-05-1		
Trimethyl methane	C4H10	75-28-5		
Trimethyl pentane-2,2,4	C8H18	540-84-1		
Trimethylamine	C3H9N	75-50-3		
Trimethylbenzene	C9H12	108-67-8		
Tungsten	W	7440-33-7		
Turpentine oil	C10H16	8006-64-2	100 ppm	
VC	C2H3Cl	75-01-4	1 ppm	5 ppm
Vinyl acetate	C4H6O2	108-05-4		
Vinyl bromide	C2H3Br	593-60-2		
Vinyl carbinol	C3H6O	107-18-6	2 ppm	
Vinyl chloride	C2H3Cl	75-01-4	1 ppm	5 ppm
Vinyl cyanide	C3H3N	107-13-1	2 ppm	10 ppm
Vinyl ethylene	C4H6	106-99-0	1 ppm	15 ppm
Vinyl toluene	C9H10	25013-15-4	100 ppm	
Vinyl trichloride	C2H3Cl3	79-00-5	10 ppm	
Vinylbenzene	C8H8	100-42-5	100 ppm	200 ppm
White spirit	85% Nonane/ 15% trimethylbenzene	8052-41-3	500 ppm	
Xylene (isomers)	C8H10	1330-20-7	100 ppm	
Xylol	C9H10	103-38-3	50 ppm	
Zinc oxide	ZnO	1314-13-2	15 mg/m ³	

APPENDIX I

REFERENCES

Many excellent reference texts and booklets are currently available. The following is a brief listing:

Laboratory Ventilation Standards

Federal Register 29 CFR Part 1910

Non-mandatory recommendations from "Prudent Practices".

- Fume hoods should have a continuous monitoring device
- Face velocities should be between 60-100 linear feet per minute (lfpm)
- Average 2.5 linear feet of hood space per person

Occupational Health and Safety

U.S. Department of Labor

200 Constitution Avenue N.W.

Washington, DC 20210

(202) 523-1452

Industrial Ventilation-ACGIH

- Fume hood face velocities between 60-100 lfpm
- Maximum of 125 lfpm for radioisotope hoods
- Duct velocities of 1000-2000 fpm for vapors, gasses and smoke
- Stack discharge height 1.3-2.0 x building height
- Well designed fume hood containment loss, <0.10 ppm

Industrial Ventilation, A Manual of Recommended Practice.

24th Edition, 2001

American Conference of Governmental Industrial Hygienists

1330 Kemper Meadow drive

Cincinnati, OH 45240-1634

(513) 742-2020

ASHRAE 110-1995 Method of Testing Performance of Fume Hoods

Evaluates fume hood's containment characteristics

- Three part test: Smoke generation, Face velocity profile, Tracer gas release @ 4 liters per minute
- Rated As Manufactured (AM), As Installed (AI) and As Used (AU)

American Society of Heating, Refrigerating, and Air Conditioning Engineers

1791 Tullie Circle N.E.

Atlanta, GA 30329

(404) 636-8400

Appendix I: References

ANSI Z9.5-2011 Laboratory Standard

Covers entire laboratory ventilation system.

- New and remodeled hoods shall have a monitoring device
- Ductless hoods should only be used with non-hazardous materials

American Industrial Hygiene Association

2700 Prosperity Avenue, Suite 250

Fairfax, VA 22031

(703) 849-8888

SEFA 1-2002

- Fume hood face velocities based on toxicity levels of chemicals
 - Class A – 125 to 150 fpm
 - Class B – 80 to 100 fpm
 - Class C – 75 to 80 fpm
- Test method – face velocity profile and smoke generation

SEFA 9-2010

- Ductless Hood Filtration Categories
 - DH1 – Ductless hood with filters
 - DH2 – Ductless hood with filters up to filter breakthrough only
 - DH3 – Ductless hood with filters past primary breakthrough with secondary backup filter protection

Scientific Equipment & Furniture Association

1028 Duchess Drive

McLean, VA 22102

(703) 538-6007

NFPA 45 – 2002 Fire Protection for Laboratories Using Chemicals

- Laboratory hoods should not be relied on for explosion protection
- Exhaust air from fume hoods should not be recirculated
- Services should be external to the hood
- Canopy hoods only for non-hazardous applications
- Materials of construction should have flame spread of 25 or less
- 80 to 120 fpm to prevent escape

NFPA 30 – 2000 Flammable and Combustible Liquids Code

- Approved cabinets may be metal or wood
- Vent location on cabinets are required
- Venting of cabinets not a requirement

National Fire Protection Association

1 Batterymarch Park

P.O. Box 9101

Quincy, MA 02269-9101

(800) 344-3555

APPENDIX J

SETTING UP THE PROTECTOR

ECHO FLOOR-MOUNTED

FILTERED HOOD

Now that the site for your floor-mounted filtered fume hood is properly prepared, you are ready to unpack, inspect, install, and certify your unit. Read this chapter to learn how to:

- Unpack and move your floor-mounted filtered hood.
- Set up the floor-mounted filtered fume hood on the floor.

Depending upon which model you are installing, you may need common plumbing and electrical installation tools in addition to 5/16", 3/8", 7/16", and 1/2" wrenches, ratchets, sockets, a nut driver set, a flat-blade screwdriver, a Phillips screwdriver, and a carpenter level to complete the instructions in the chapter.



The Protector Echo Floor-Mounted Filtered Hood models weigh between 700 to 1500 lbs. (318-675 kg). The multiple shipping pallets allow for lifting with a mechanical lift truck or floor jack. If you must lift the fume hood manually, follow safe-lifting guidelines.

Les modèles filtrée protégé-capot Echo monté au plancher pèsent entre 700 à 1500 livres. (318 à 675 kg). Les multiples palettes d'expédition permettent de levage avec un chariot élévateur mécanique ou prise de parole. Si vous devez soulever la hotte manuellement, suivre les directives safe-levage.

Unpacking Your Floor-Mounted Filtered Fume Hood

The United States Interstate Commerce Commission rules require that claims be filed with the delivery carrier within fifteen (15) days of delivery.

Your Protector Echo Floor-Mounted (Walk-In) Filtered Hood has been shipped to you as ten main component assemblies located on three shipping skids. The ten main component assemblies consist of the lower base, upper cabinet, sashes, lower sash track, corner posts, service fixtures, electrical connections, baffles, header, and front panel.

Carefully remove the shrink-wrap or carton on your filtered fume hood and inspect it for damage that may have occurred in transit. If your unit is damaged, notify the delivery carrier immediately and retain the entire shipment intact for inspection by the carrier.

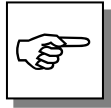

DO NOT RETURN GOODS WITHOUT THE PRIOR AUTHORIZATION OF LABCONCO. UNAUTHORIZED RETURNS WILL NOT BE ACCEPTED.

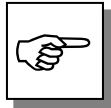

IF YOUR HOOD WAS DAMAGED IN TRANSIT, YOU MUST FILE A CLAIM DIRECTLY WITH THE FREIGHT CARRIER. LABCONCO CORPORATION AND ITS DEALERS ARE NOT RESPONSIBLE FOR SHIPPING DAMAGES.

Do not discard the shipping skid or packing material for your floor-mounted filtered fume hood until you have checked all of the components and installed and tested the unit. **Many components of the floor-mounted filtered hood are shipped loose such as baffles and corner posts and do not discard. See Figures J-1 through J-5.** Do not remove the filtered fume hood from its shipping skids until it is ready to be placed into its final location. Move the unit by placing a flat, low dolly under the shipping skid, or by using a floor jack.



Do not move the filtered hood by tilting it onto a hand truck.

Ne pas déplacer le capot filtrée en l'inclinant sur un camion de main.

Removing the Shipping Skid

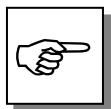

LEAVE THE FILTERED FUME HOOD ATTACHED TO ITS SHIPPING SKID UNTIL IT IS AS CLOSE TO ITS FINAL LOCATION AS POSSIBLE. MOVE THE HOOD BY USING A SUITABLE FLOOR JACK, OR BY PLACING A FURNITURE DOLLY UNDERNEATH THE SKID. DO NOT MOVE THE HOOD BY TILTING IT ONTO A HAND TRUCK.

After you verify the filtered fume hood components, move your hood to the location where you want to install it. Then, follow the steps listed next to remove the separate shipping skids from the lower base and upper cabinet.

1. Remove the side panels by unscrewing the Phillips screws.
2. Find the hardware (bolts, washers, nuts) that attach the filtered fume hood to the skid and remove the hardware. Some hardware is on the sides and some is on the back.

Sash Weight Release

On Filtered Floor-Mounted Hood models with vertical-rising sashes, the sash weights have been secured to the shipping skid. Remove the weights from the skid and attach them to the respective sash cables using the hooks provided.

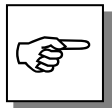

NOTE: THE SASH WEIGHT ITSELF WAS INDIVIDUALLY MATCHED FOR THIS SPECIFIC FILTERED HOOD AND SHOULD NOT BE EXCHANGED ON ANY OTHER UNIT.

Disassembly and Reassembly of the Protector Echo Floor-Mounted Filtered Hood

There may be some disassembly and reassembly work, due to the large physical size of your filtered hood and the ability to maneuver it into your laboratory. This is specific to each customer.

Lower Base Installation of the Protector Echo Floor-Mounted Filtered Hood

The lower base features a panelized liner surrounded by an epoxy-coated steel and galvanized steel framework. Both the left and right side panels should be removed to allow for the correct placement of the lower cabinet assembly. Temporarily remove both vertical-rising sashes shipped with the lower base (on vertical-rising sash models only). Position the lower base on a level floor surface. Place the vertical-rising sashes back in place (on vertical-rising sash models only).

NOTE: If an optional floor surface is purchased, it should be positioned on the existing floor prior to placement of the lower cabinet installation. See Figure J-1.

Upper Cabinet Installation of the Protector Echo Floor-Mounted Filtered Hood

Remove the upper cabinet assembly side panels and front panels prior to cabinet placement. Then place the upper cabinet assembly on top of the lower base assembly, being careful to clear the lower base assembly during placement. To prevent spillage from seeping between the two liner assemblies, run a bead of white RTV sealant between the sections once they have been properly aligned. Mount the lower base to the upper cabinet using the 1/4-20 hex head screws, lockwashers, and nuts included in your hood package. See Figure J-2.

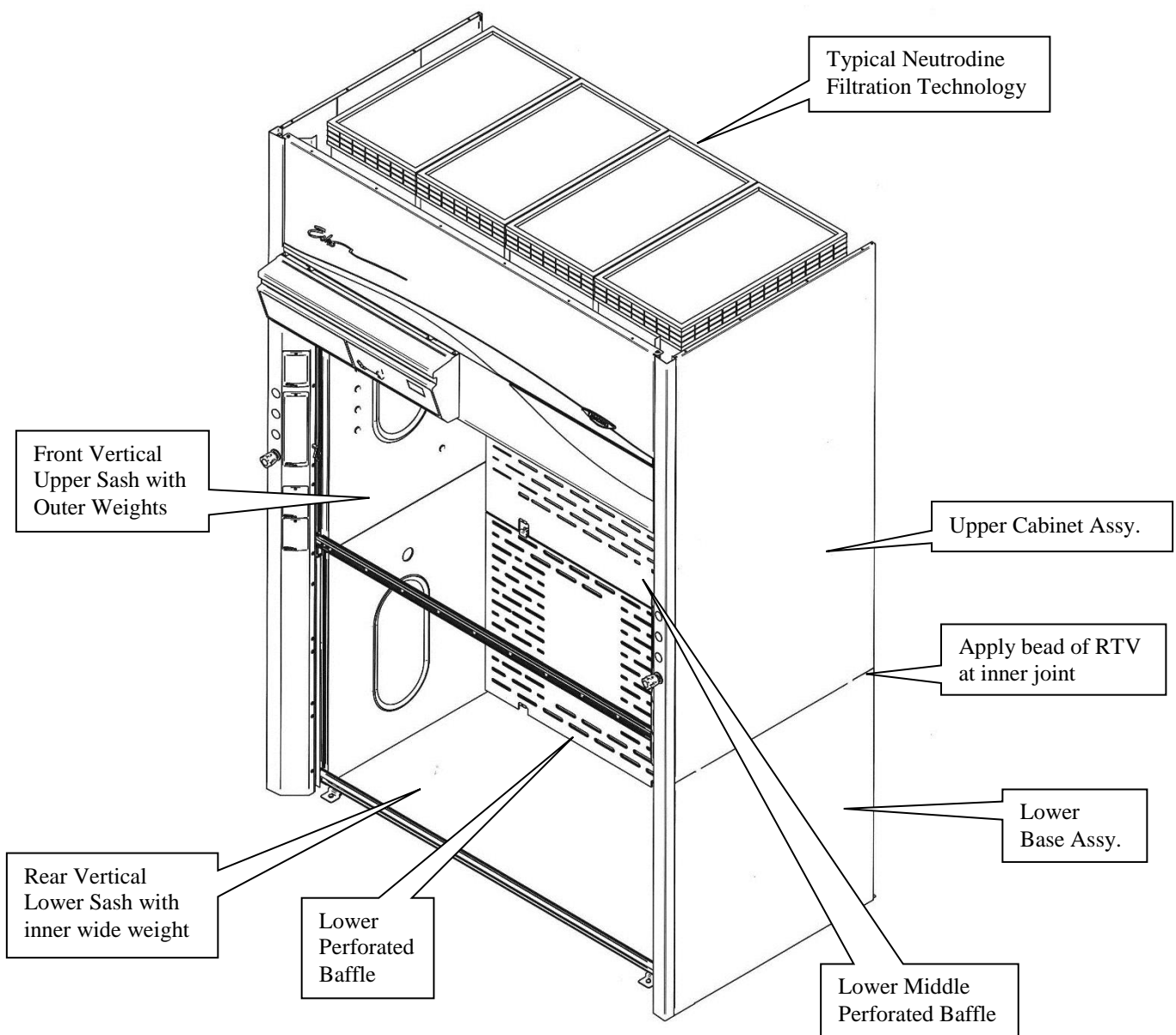

Figure J-1

Vertical-Rising Sash Installation for the 4', 5', 6', & 8' Protector Echo Floor-Mounted Filtered Hoods

The Protector Echo Floor-Mounted Filtered Hood has two vertical-rising sashes. The rear vertical-rising sash moves from the floor to full open and picks up the front vertical-rising sash, which travels from the midpoint to full open. The vertical rising sashes are shipped captured between the hood side frame assemblies of the lower base assembly. Both upper and lower sash tracks are attached to the side frames. The hood should be at a pre-assembled state with the top section bolted to the base, and the sashes still captured between the two side frames. Bring the sides back and adjust the sash tracks left and right to assure that each sash will work properly and tighten all hardware.

Now that the sashes are in place, the counterbalance weights must be installed. The large single sheet metal sash weight is installed in the middle and attached to the lower rear sash. The two individual sash weights counterbalance the front vertical-rising sash; these weights have rollers and ride in the rear sash tracks that straddle the middle sheet metal sash weight. Install the rear weight tracks for the individual sash weights with the #10-24 screws and #10-24 KEPS nuts supplied. See Figures J-2, J-3, and J-4. It is vitally important that the front upper and lower sash tracks are fully aligned and the strap plates are used to secure this alignment. See Figure J-3 and Figure J-4. Once the sashes are aligned and operating freely, secure the lower base to the floor with sealant or fasteners. (Note: Hardware not supplied due to installation variables.) Securing the lower base will ensure the sashes will work freely.

As a last step, install the four rubber bumpers with #6 screws supplied. One set of rubber bumpers prevents the front upper sash from traveling too low. The second set of rubber bumpers prevent the rear lower sash from touching the floor and provides a good sweep of clean air across the floor. See Figure J-3.

Appendix J: Setting Up the Protector Echo Floor-Mount

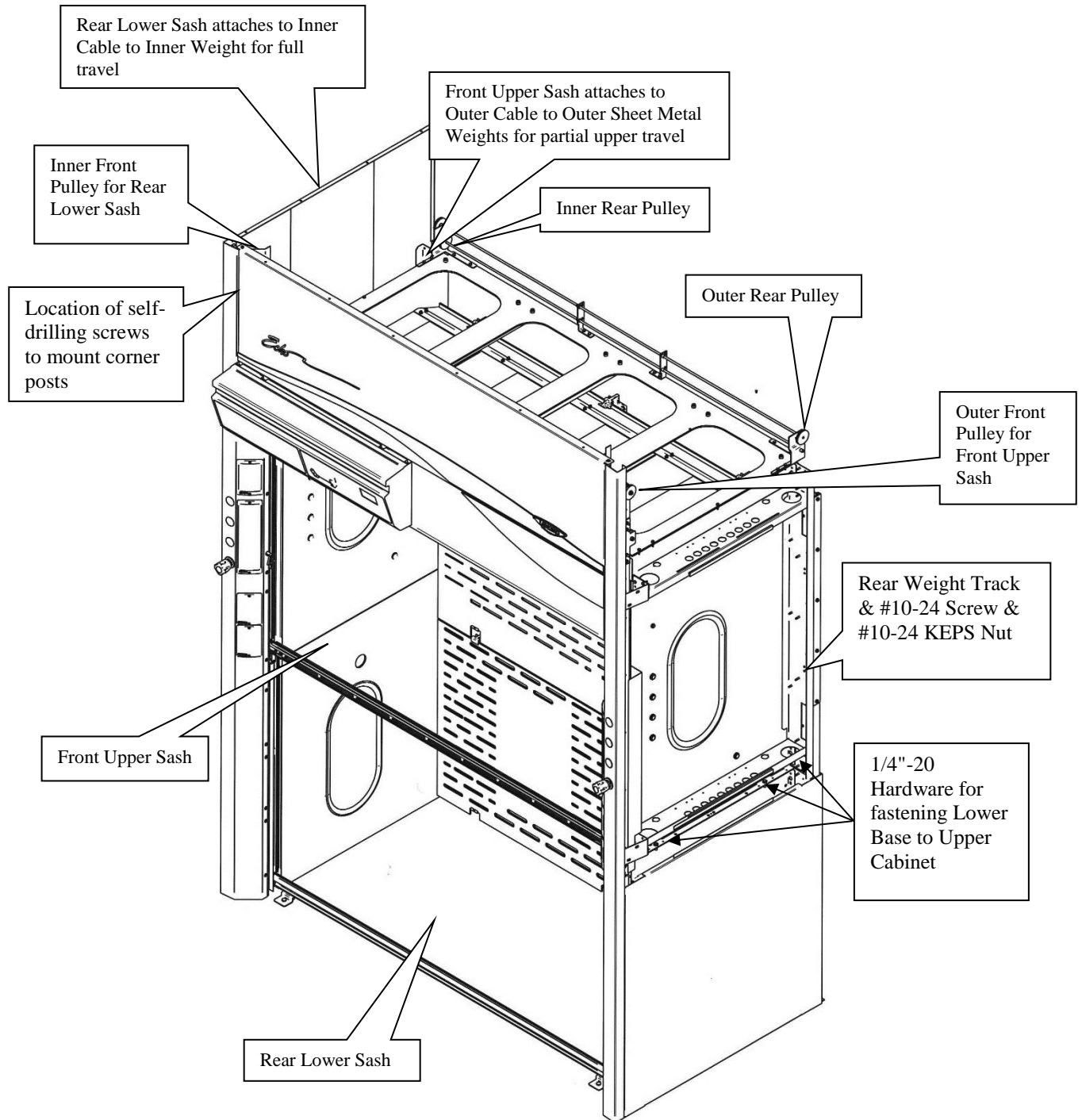

Figure J-2

Appendix J: Setting Up the Protector Echo Floor-Mount

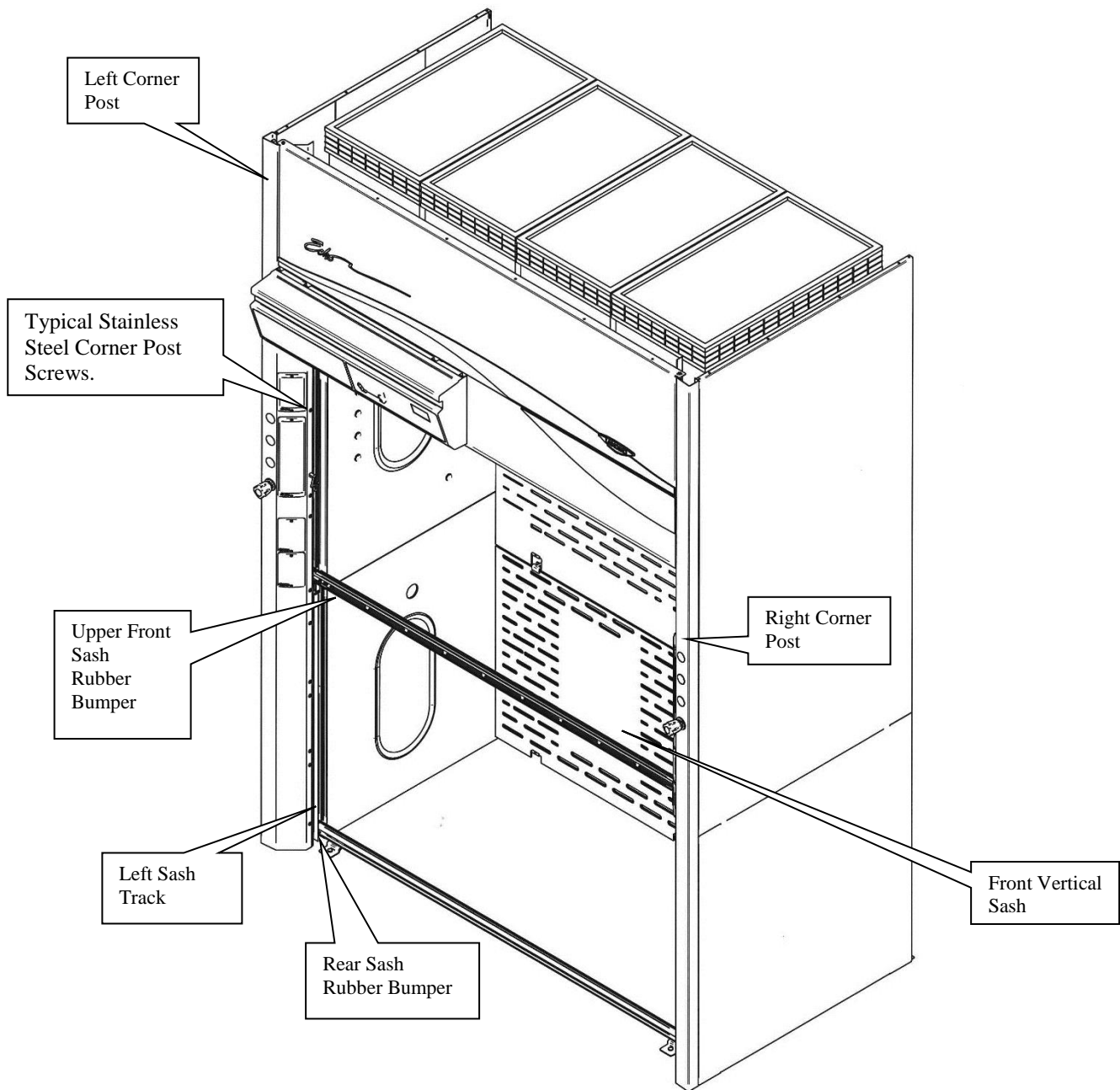
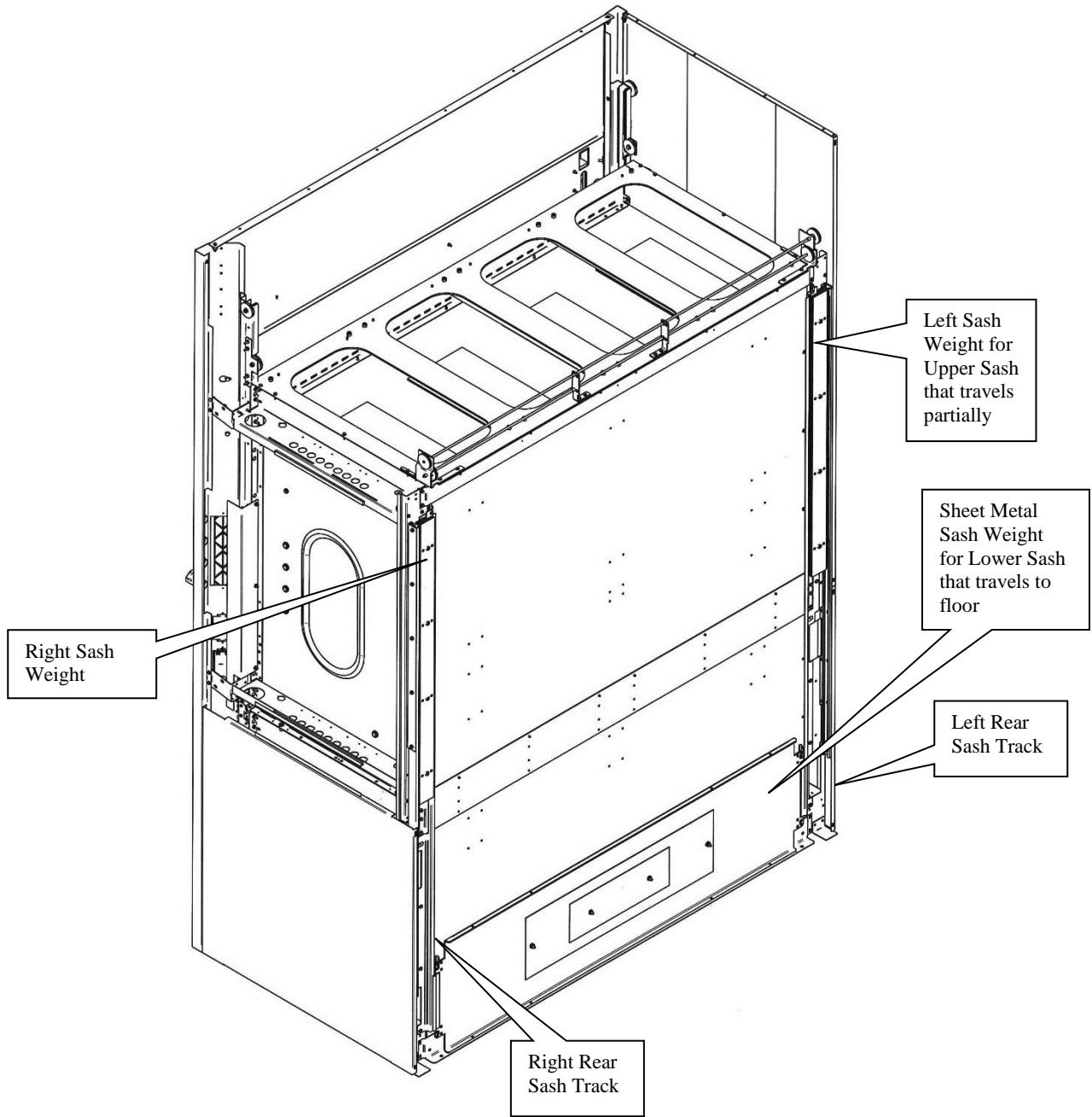

Figure J-3

Appendix J: Setting Up the Protector Echo Floor-Mount



Rear View

Figure J-4

Corner Post Installation for the Floor-Mounted Filtered Hoods

Both left and right corner posts have been shipped uninstalled. The one-piece corner posts are to be installed once the upper and lower cabinet assemblies have been properly positioned.

The edges on the corner posts fit directly onto the side frames. The front inner edge of both corner posts are held in place by stainless steel machine screws. The outer back edge of both corner posts are held in place with steel self-drilling screws. The screws are included in the hood manual packet. See Figure J-2 and Figure J-3.

Baffle Installation for the Floor-Mounted Hoods

The baffles are critical to the proper airflow and performance of the hood. Be sure the baffles are resting in the proper baffle mount supports. Pay attention to the upper baffles that require a small baffle connected to a large baffle via a brace, hardware, and hardware covers. See Figures J-1 and J-5 for various sizes of baffles and their orientation.

Appendix J: Setting Up the Protector Echo Floor-Mount

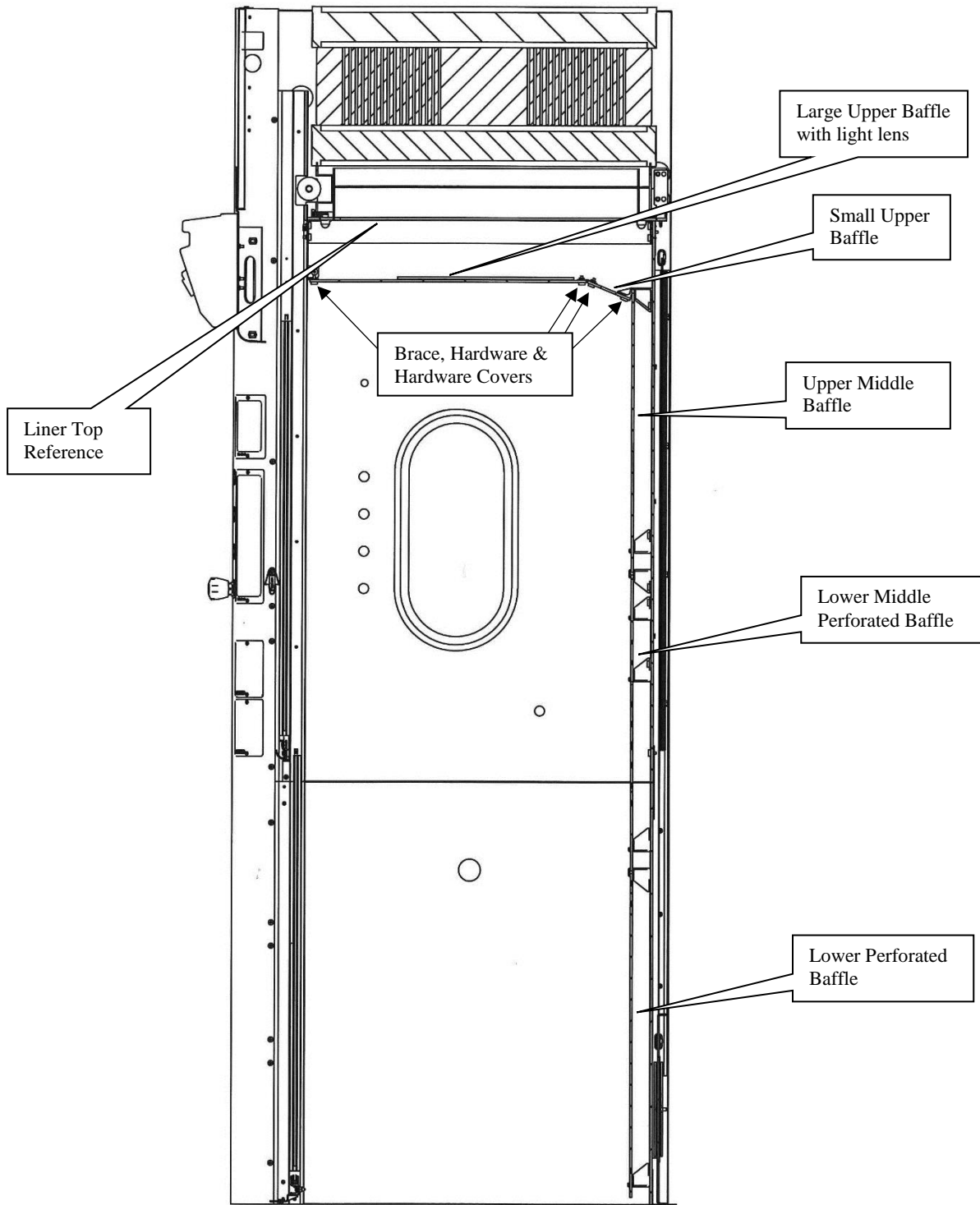

Figure J-5

Header Installation for the Floor-Mounted Filtered Hoods

The header is shipped separately in its protective packaging. To install, the header is fastened to the corner covers by four #12 screws. Reach behind the corner posts from the side and install the screws to support the header. See Figure J-6.

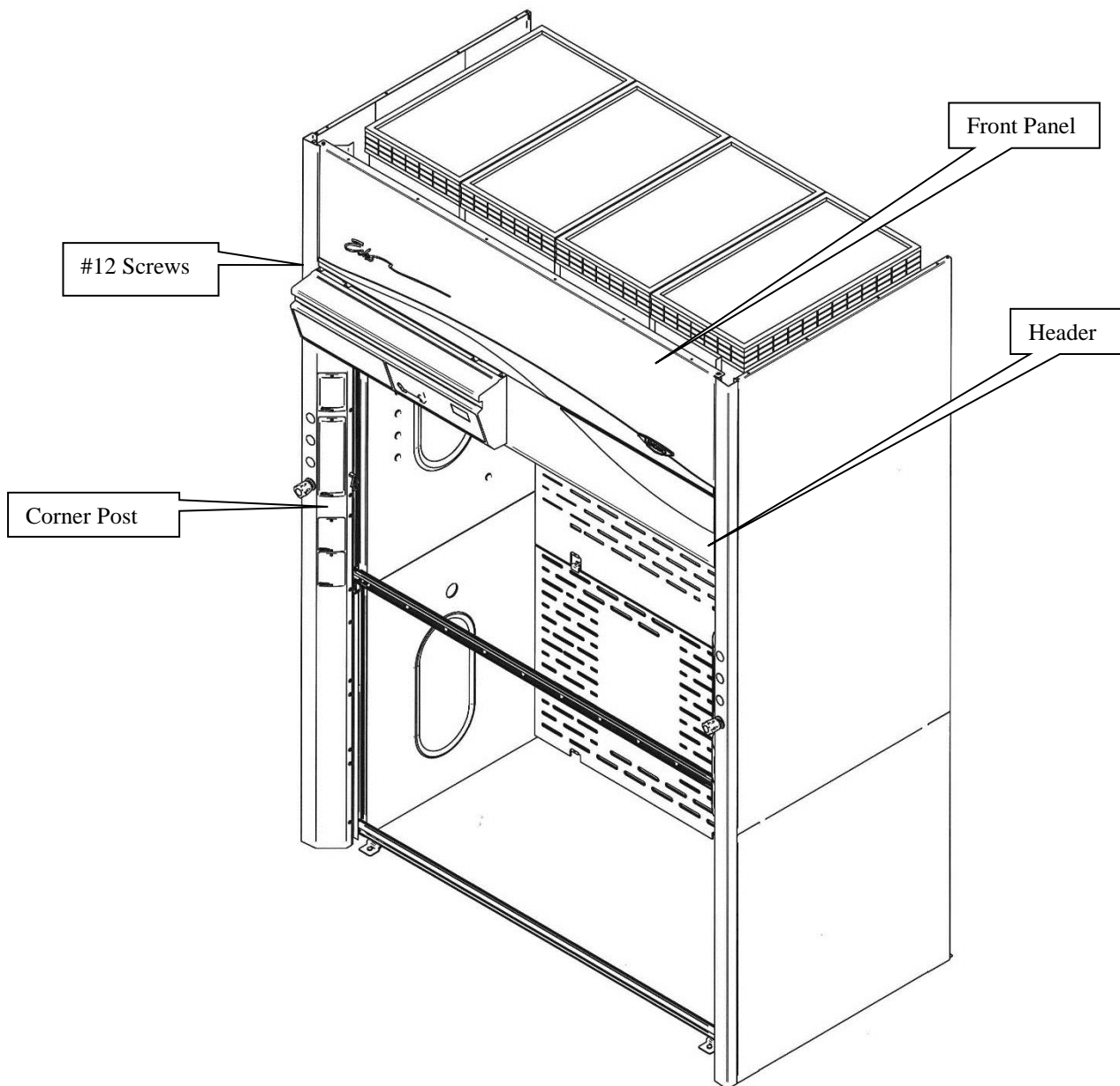

Figure J-6

Front Panel Installation for the Floor-Mounted Filtered Hoods

The hood front panel is shipped separately and is protected. To install each panel, hang the two plastic cylinders on the backside of the front panel over the corner posts. The bottom of the front panel will then slip behind the header once it has been properly secured at the top. See Figure J-6.

APPENDIX K

SMALL 54.2" HEIGHT

AIRO DIMENSIONS

The following pages provide dimensional data for the small 54.2" height Protector Airo Filtered Fume Hoods.

Appendix K: Small 54.2" Height Airo Dimensions

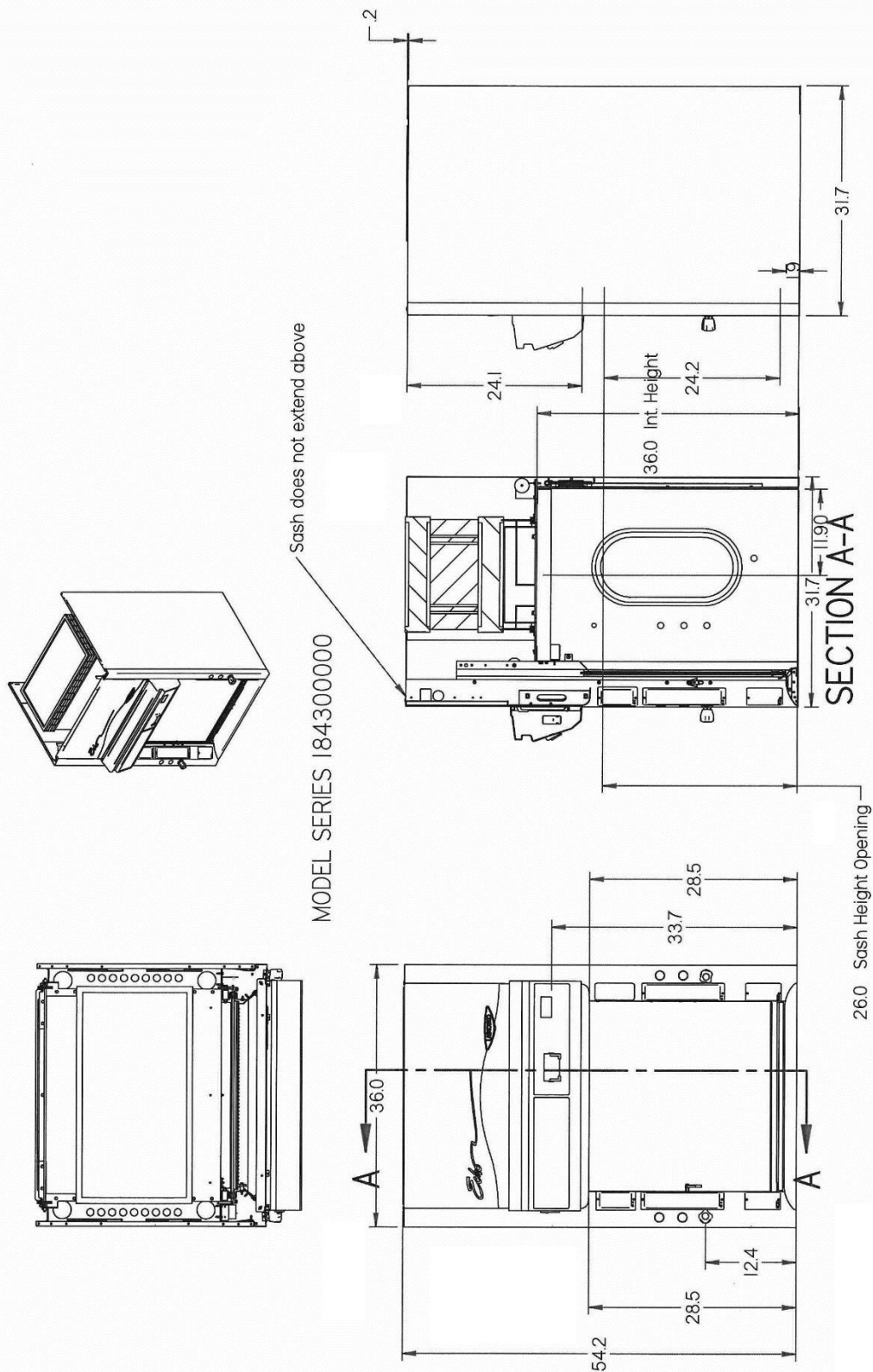

Figure K-1

Appendix K: Small 54.2" Height Airo Dimensions

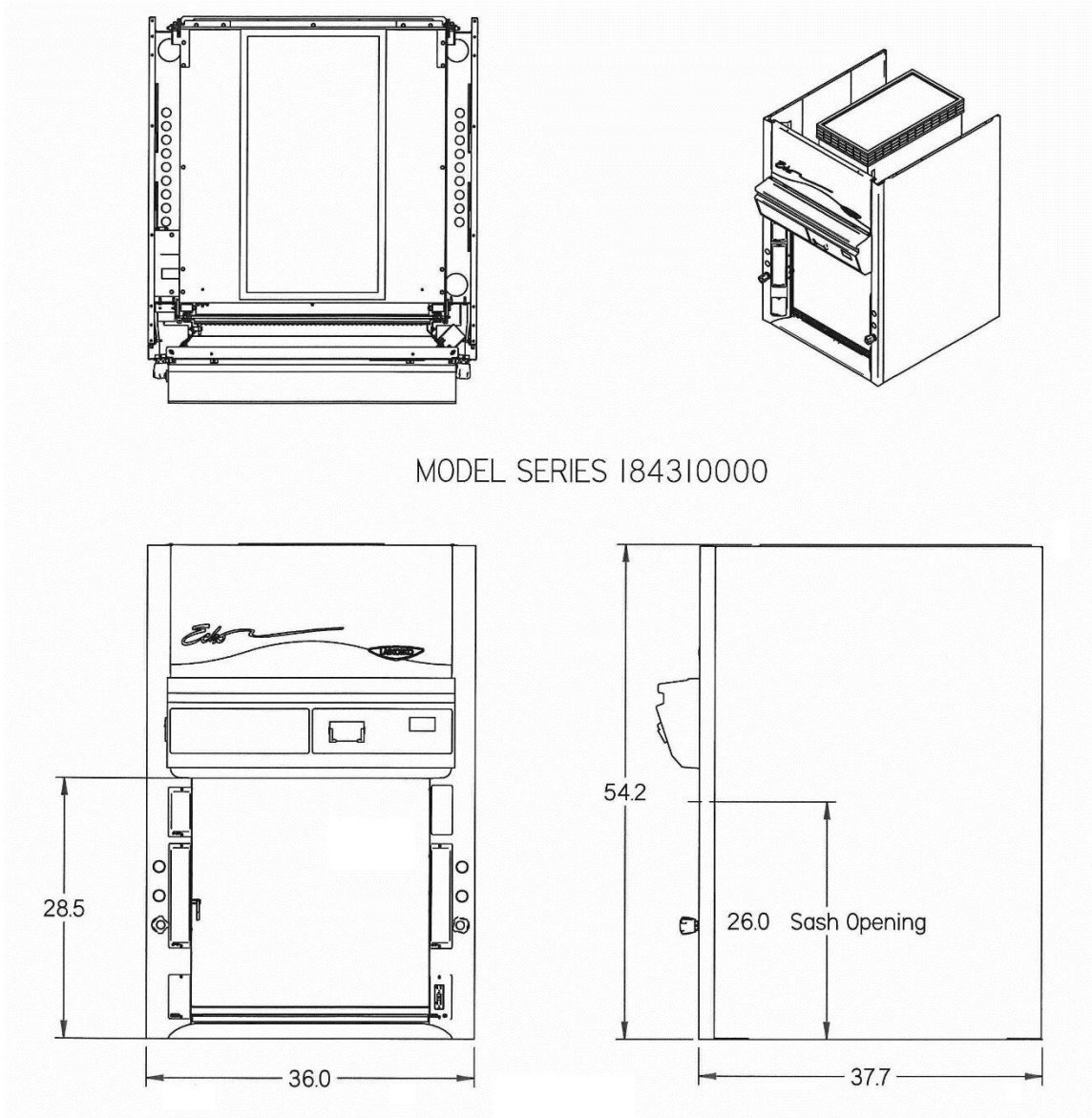
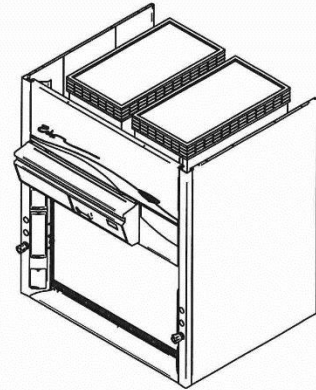
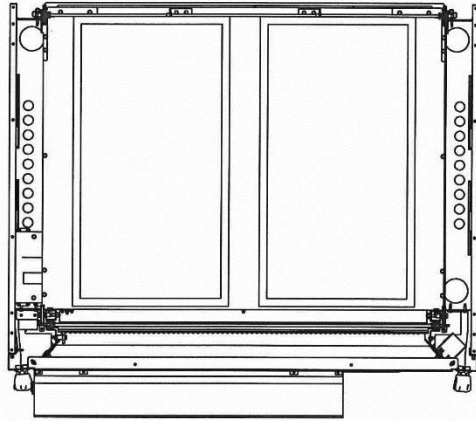

Figure K-2

Appendix K: Small 54.2" Height Airo Dimensions



MODEL SERIES I844I0000

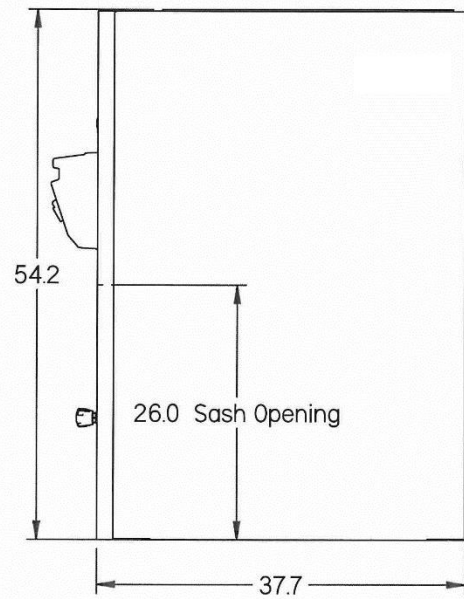
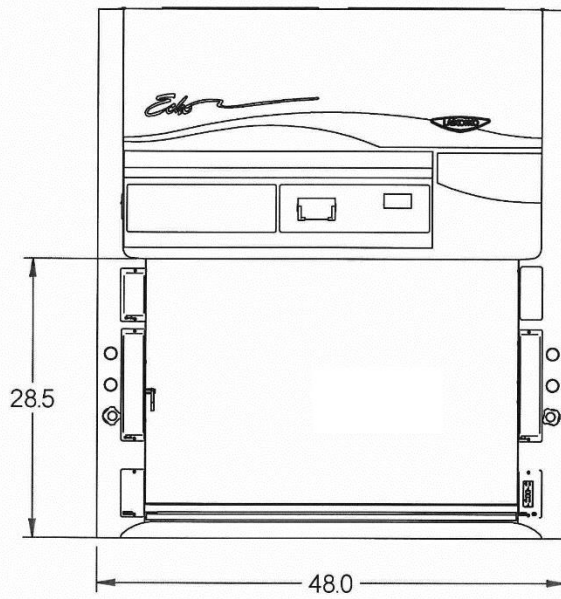

Figure K-3